



SPECTR EE 9

FIELD MANUAL



Table of Contents

- 1 [WARNING](#)
- 2 [AMMUNITION SELECTION](#)
- 3 [OVERVIEW & PRODUCT SPECS](#)
- 4 [ASSEMBLY](#)
 - 5 [ALPHA DIRECT THREAD MOUNT](#)
 - 6 [ALPHA ASR MOUNT](#)
 - 8 [ALPHA PISTON MOUNT](#)
 - 9 [3-LUG MOUNT](#)
- 10 [MAINTENANCE](#)
- 11 [LIMITED LIFETIME WARRANTY](#)
- 12 [REGISTER & SUPPORT ASA](#)





Warning

Failure to follow installation and maintenance instructions detailed in this manual may result in **serious personal injury** and damage to the firearm. **Do not attempt to use this product unless you have specific training and experience in the use of firearms.**

Because suppressed firearms make less noise than unsuppressed firearms, it is easy to forget that they are still firearms and capable of causing bodily injury and property damage. Remember, a suppressed firearm should be treated with the same safety and caution as an unsuppressed firearm.

Firearm silencers are user-attached firearm muzzle devices, and as such are subject to improper attachment issues unless the procedures outlined in this manual are followed precisely.

Before installing the silencer on the host firearm, be sure the firearm is unloaded and the action is opened so the firearm is visibly clear of any ammunition. If you are at all unsure as to the proper procedures to ensure your firearm is unloaded, please consult your firearm user's manual/instructions and/or contact a properly licensed dealer or the manufacturer or gunsmith of your firearm.

Check the fit between barrel and silencer before firing! The mount must be fully shouldered on the barrel. There should be no visible gap between the barrel shoulder and the face of the silencer thread mount. Poor accuracy and product damage may result if the silencer is not properly shouldered.

Silencers must be free of obstructions such as mud, dirt, etc. DO NOT attempt to shoot through an obstructed silencer. If submerged in water, the user must allow sufficient time to drain the silencer completely.

To ensure your silencer remains secure while firing, it is of the utmost importance that you frequently verify the silencer is securely tightened onto the barrel. We recommend checking the security of the attachment after 30 discharges of the firearm.

Before removing the silencer from the host firearm, be sure the firearm is unloaded and the action is opened so it is visibly clear of any ammunition. When removing the silencer, use extreme caution as it may be hot to the touch after firing. Use heat-resistant gloves to avoid burns or other injuries. Once the silencer is removed from the host firearm, SilencerCo recommends using a thread protector or other muzzle device to protect the muzzle threads and crown, during storage or transport.



Ammunition Selection

The silencer is designed to suppress the initial muzzle blast and subsequent projectile de-corking pressure. The silencer doesn't contact or otherwise interact with the bullet, allowing the projectile to travel at its default speed. Because of this, a sonic crack may be produced by the projectile as it breaks the sound barrier.

Depending on the geography of the area, the sonic crack may vary in volume. This is solely a function of the projectile breaking the sound barrier and is not related to product performance.

If desired, sonic crack can be avoided with the use of subsonic ammunition. Subsonic ammunition can be identified by a muzzle velocity that does not exceed the speed of sound. The speed of sound in an environment increases with temperature, and ranges between 1000 feet per second (at approx -40°F/-40°C) and 1200 feet per second (140°F/60°C).

Do not use ammunition withunjacketed lead bullets. Exposed lead projectiles will deposit lead inside your silencer and cannot effectively be removed.



Overview & Product Specs

The Spectre 9 is the next evolution in SilencerCo's collection of titanium suppressors. It's completely constructed from titanium and designed for pistol and subgun platforms. The Spectre 9 is extremely lightweight due to its construction and compact for minimal impact. It's a great option for personal protection, low-visibility applications, or days at the range.

The Spectre 9 is compatible with 9MM and subsonic 300 BLK (full auto subs & semi auto supers). It's even full-auto rated and one of the few suppressors that can run on a full-auto Glock.

It's compatible with the SilencerCo Alpha accessories and mounting systems and ships with a tool and the Spectre Piston Housing Assembly.

Product Specs

CALIBERS

9MM & .300 BLK *Full auto subs & semi auto supers*

MATERIALS

Ti Grade 5 & Ti Grade 9

DIAMETER

1.37"

WEIGHT

3.9 oz

LENGTH

4.76"

dB Readings

9MM

132.7 dB

.300 BLK

134.7 dB

Included



SPECTRE 9
SU5422



SPECTRE 9
PISTON ASSEMBLY



SPECTRE TOOL



ALPHA TOOL



Assembly

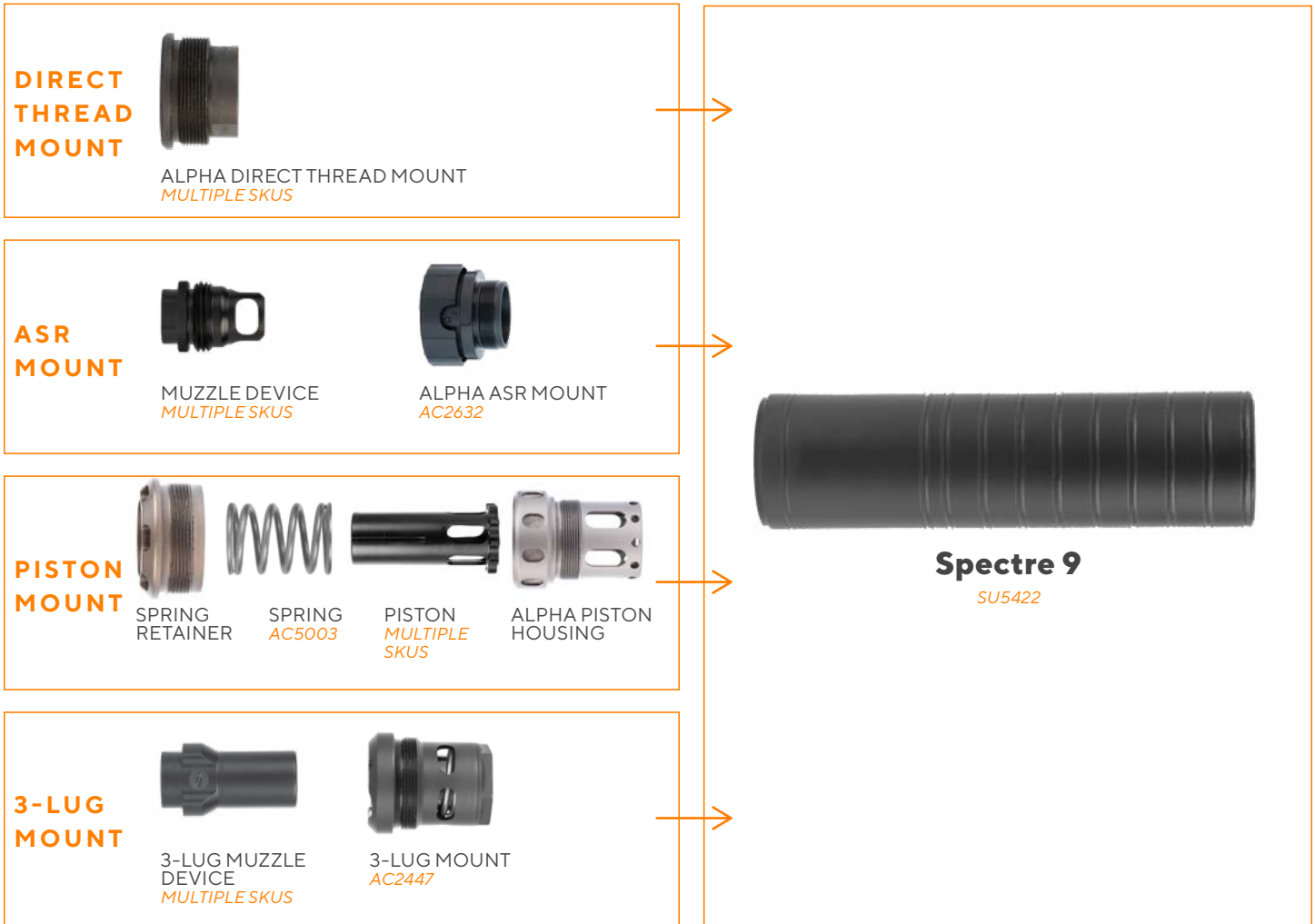

MOUNTING OPTIONS

For optimum performance and to avoid damage to your silencer, SilencerCo recommends using only SilencerCo mounts and accessories.

Whichever way you choose to mount your silencer to your firearm, you should take care to ensure your silencer is mounted securely before firing. SilencerCo offers mounts in all common barrel thread patterns.

Users must ensure they are using the proper mounts that match their barrel threads and that there is a proper shoulder for the mount to seat against. Following these instructions will help to prevent the problems and dangers that can arise from improper installation.



Assembly

Direct Thread Mount



INSTALLATION & REMOVAL

Install the Alpha Direct Thread Mount into the silencer by hand to avoid cross-threading. Use the Spectre Tool to tighten the mount to the silencer body to approximately 20-30 ft-lbs.

Screw the silencer onto the barrel until it is properly shouldered. Hand tighten to approximately 10-15 ft-lbs. For proper alignment, it is essential that the mount seats against a clean 90° barrel shoulder.

To remove, perform steps in reverse order.

READY FOR USE

When removing the Spectre 9 from the barrel, the mount may stay threaded onto the barrel, causing it to unthread from the silencer body. The Alpha Direct Thread Mount features internal wrench flats for this situation.

Completely remove the Spectre 9. Seat an open end wrench (wrench sizes will vary by thread mount size) onto the front side of the thread mount and remove. Reinstall the mount into the Spectre 9.



Assembly

ASR Mounting System

ASR MOUNT

The ASR Mount is a proprietary quick-attach/detach mounting system, and as such requires a compatible muzzle device (muzzle brake or flash hider). SilencerCo recommends the use of the included shim kit if any indexing of the mount is required. Crush washers are NOT recommended as they do not crush uniformly and WILL cause improper mounting and baffle strikes. For proper alignment, it is essential that the muzzle device seats against a 90° barrel shoulder.

[WATCH ASR MOUNT VIDEO](#)

MUZZLE DEVICES

Thread the ASR muzzle device onto the barrel. Use the provided shim kit to ensure proper ASR muzzle brake alignment. Timing with shims is not necessary on ASR flash hiders. Tighten onto barrel using the wrench flats at the rear of the brake. Use of Rocksett™ or another high-temp threadlocker is recommended to secure the muzzle device. Muzzle devices should be tightened to approximately 20-30 ft-lbs.

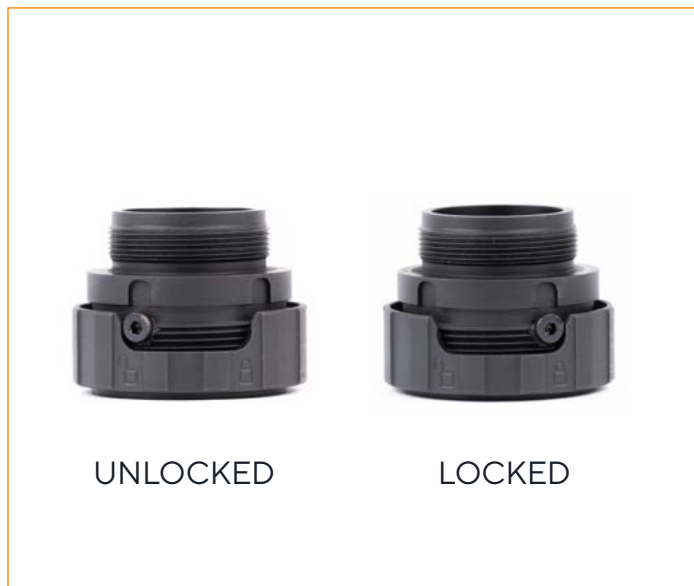

Assembly

ASR Mounting System

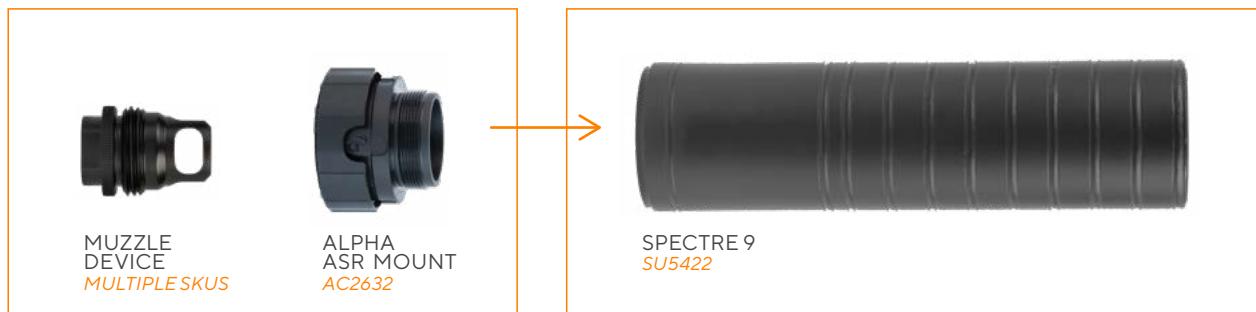

INSTALLATION & REMOVAL

Thread on the ASR mount. Use one of the included spanner wrenches to tighten the ASR mount body to approximately 20-30 ft-lbs.

To remove, perform steps in reverse order.

MOUNTING TO THE FIREARM

Verify the ASR collar is in the **unlocked A** position before installing on your firearm. Install the silencer by sliding the back end over the muzzle device, then screw the silencer onto the muzzle device until it is firmly seated against the shoulder.

Rotate the ASR collar to the **locked B** position until the closed padlock icon appears.

To remove, perform steps in reverse order.

READY FOR USE





Assembly

Piston Mount

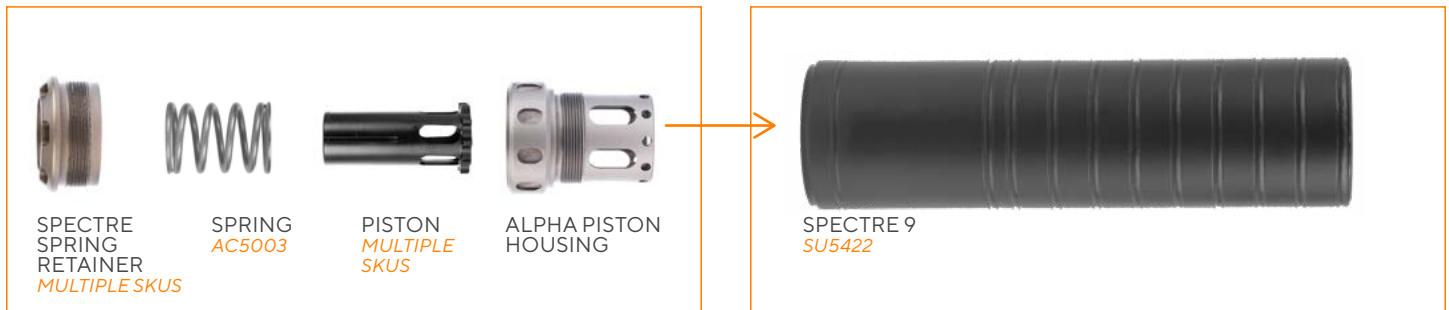

INSTALLATION & REMOVAL

Place the spring over the piston as shown, then insert the piston and spring assembly into the Alpha Piston Mount.

Insert the Piston Mount assembly into the back of the Spectre 9. Thread the Spectre Spring Retainer into the back of the Alpha Piston Mount. Use the provided wrench to first tighten the Spectre Spring Retainer, then to tighten the entire assembly into the silencer body.

Thread the silencer onto the threaded barrel of your pistol. Hand tighten only.

To remove, perform steps in reverse order.

READY FOR USE



Assembly

3-Lug Mount

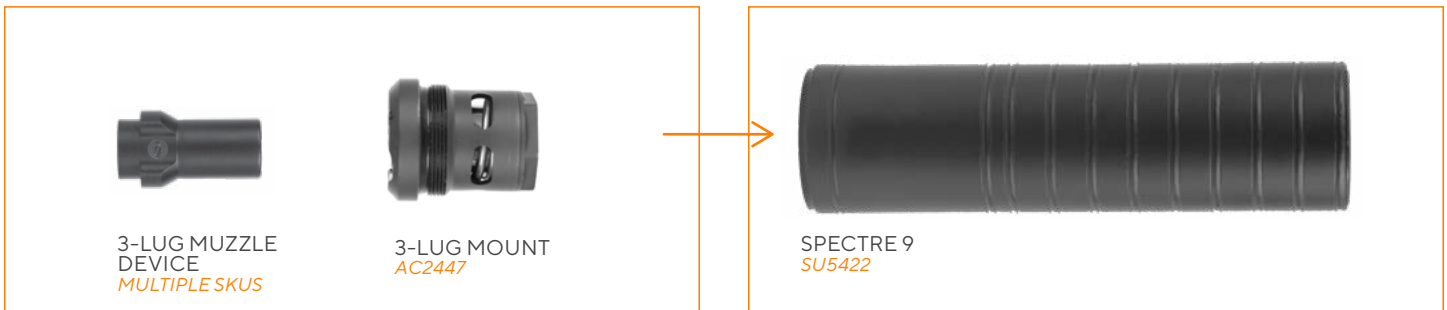

WARNING

ONLY use 9mm muzzle devices with 9mm 3-Lug mounts. While a 9mm muzzle device will fit inside the 45 3-Lug mount, the excessive clearance greatly increases chances of damage due to potential misalignment.

INSTALLATION & REMOVAL

Screw the 3-Lug Mount into the silencer. Tighten with provided 3-pin wrench.

Screw the appropriate 3-Lug muzzle device onto the barrel threads and tighten to approximately 10-20 ft-lbs. For proper alignment, muzzle device must seat against a 90° barrel shoulder. Depending on the thread pattern, some muzzle devices will shoulder on the nose of the barrel.

Align the lugs of the muzzle device with the cut-outs of the mount. Compress the silencer against the muzzle device, turn the silencer 60 degrees, then release. Pull on the silencer to ensure it is securely mounted before firing.

To remove, perform steps in reverse order.

READY FOR USE





Maintenance

The Spectre 9 typically requires limited maintenance. To ensure proper alignment and prevent silencer damage, mounts and mounting surfaces should periodically be cleaned with any standard gun cleaning solvent and a brush to remove any carbon or fouling.

Do not run cleaning patches through the bore as the patches might become lodged in the silencer and cause damage upon firing.

Functionally similar to a car muffler, cleaning of the internal volume and baffles is not necessary.

CAUTION

*Always read the warning label on any cleaner or solvent, and remember that virtually all solvents are **inherently dangerous and potentially toxic.** Always use adequate ventilation and both skin and eye protection when using solvents.*

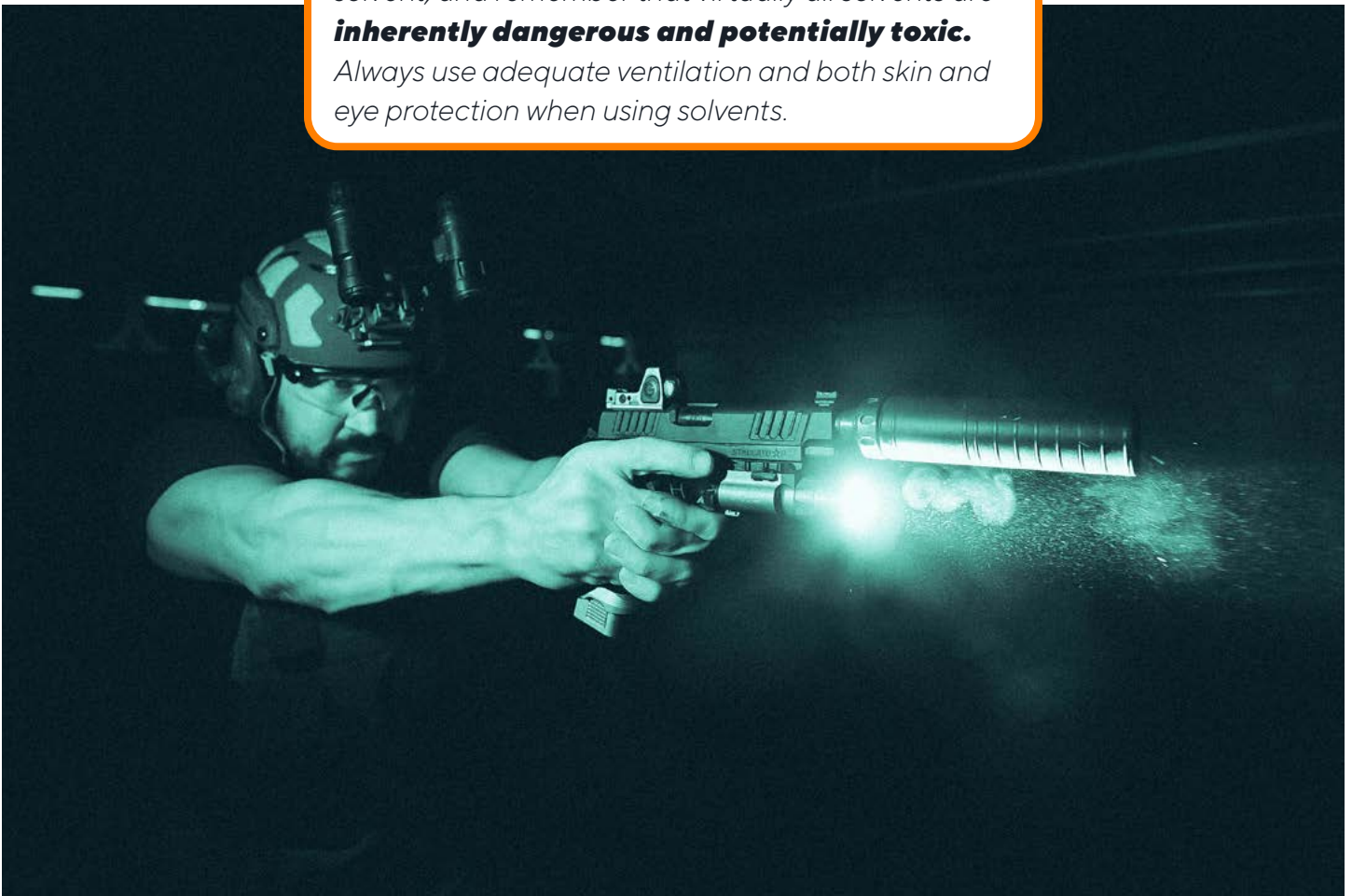



Limited Lifetime Warranty

Silencerco, LLC (“**SilencerCo**”) warrants to you that if any product sold by SilencerCo’s and used for its intended use ever becomes defective, SilencerCo’s will repair or replace the product at no charge, other than shipping, subject to the conditions set forth below.

THE WARRANTY EXTENDS ONLY TO THE ORIGINAL REGISTERED PURCHASER.

This warranty does not cover damage to our products or host firearm resulting from careless or irresponsible handling adjustments or modifications to its intended design, negligence, or other unforeseeable abuse. SilencerCo assumes no liability for unsafe or illegal use of the silencer by its purchaser or any other user that comes in contact with the product after purchase. SilencerCo assumes no responsibility for physical injury or property damage resulting from careless or irresponsible handling or by any use contrary to the recommendations, warnings and cautions generally listed in this manual. SilencerCo does not cover damage to the silencer or host firearm resulting from improper “**hand-loaded, reloaded, previously used or otherwise defective ammunition.**” **THIS WARRANTY IS FURTHER REGULATED BY RELEVANT AND APPLICABLE STATE AND FEDERAL LAWS.**

If SilencerCo’s determines that you satisfy the conditions for warranty coverage under this limited warranty, SilencerCo’s will, at no charge, replace or repair the SilencerCo product with the

same or similar model subject to the terms herein. If no replacement is available, and SilencerCo determines that the product cannot be repaired, SilencerCo will replace your nonperforming or defective unit with a unit that, in SilencerCo’s sole determination, is substantially similar to your lawfully purchased and registered product. This warranty extends to any and all parts as originally sold by us, but **does not extend to any altered product or firearm that is altered or rebuilt after original purchase, damaged through abuse, misuse through lack of proper care and maintenance, or used other than for its legal intended purposes.**

SILENCERCO’S LIABILITY FOR BREACH OF ANY WARRANTY WITH RESPECT TO A SILENCERCO PRODUCT SHALL BE LIMITED TO REPLACING OR REPAIRING THE NONPERFORMING OR DEFECTIVE PRODUCT AS DESCRIBED IN THIS LIMITED WARRANTY. THIS LIMITED WARRANTY SHALL BE YOUR SOLE AND EXCLUSIVE REMEDY WITH RESPECT TO A NONPERFORMING OR DEFECTIVE PRODUCT, AND SILENCERCO WILL NOT BE LIABLE FOR ANY OTHER DAMAGES, INCLUDING DIRECT, INCIDENTAL OR CONSEQUENTIAL DAMAGES OR DIMINUTION IN VALUE DUE TO REPAIR OR REPLACEMENT WITH A DIFFERENT PRODUCT.

For assistance with repairs, please contact our consumer service department at **801.417.5384**.



Register Your SilencerCo Product Online To Activate Your Lifetime Warranty



Protect Your Rights | Protect Your Hearing

The American Suppressor Association is fighting to protect and expand your silencer rights. Join the fight today!

For questions, contact our customer service team at **801.417.5384** or **info@silencerco.com**

© Silencerco, LLC. All rights reserved. The contents of this publication may not be reproduced in any form or by any means in whole or in part without the prior written permission of the copyright owner.