

Ø 1.38

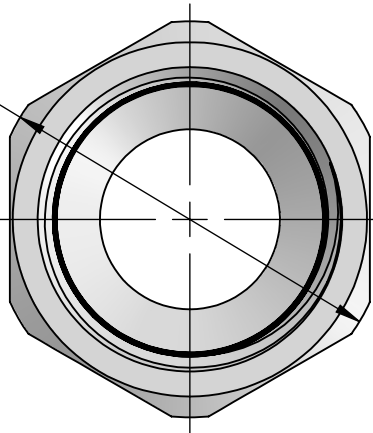

BODY

1.75 APPROX.

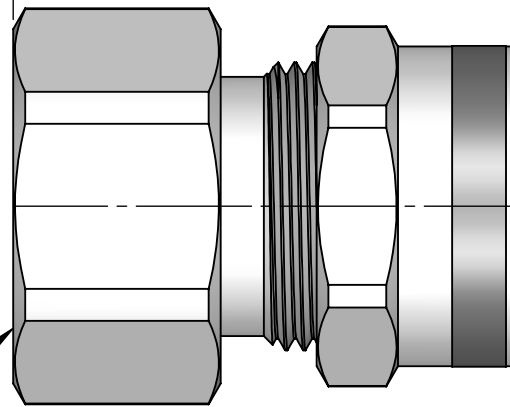

3/4 N.P.T.
INTERNAL THREAD

Ø 1.25

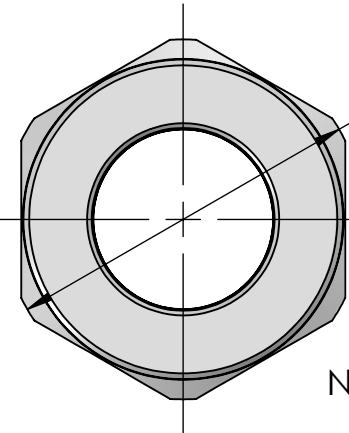

NUT



ITEM NO.	PART NUMBER	DESCRIPTION	MATERIAL	QTY.
1	RSRF-2100-B	BODY	ALUMINUM	1
2	SRB-103 - 110	BUSHING	NEOPRENE	1
3	RSR-100-NB	NUT	ALUMINUM	1
4	SW-100	WASHER	C.R.S. ZINC PLATED	1

PART NUMBER	SEALING RANGE	BODY BORE
RSRF-2103	.125 - .188	.625
RSRF-2104	.188 - .250	.625
RSRF-2105	.250 - .312	.625
RSRF-2106	.312 - .375	.625
RSRF-2107	.375 - .438	.625
RSRF-2108	.438 - .500	.625
RSRF-2109	.500 - .562	.625
RSRF-2110	.562 - .625	.625

REV.	DATE	CHANGE	UNLESS OTHERWISE SPECIFIED:	NAME	DATE	REMKE REMKE INDUSTRIES 310 CHADDICK DR, WHEELING, IL. 60090	
A	7/1/15	DRAWING RELEASED	DIMENSIONS ARE IN INCHES TOLERANCES: FRACTIONAL ± 1/64 ANGULAR: MACH ± 1° BEND ± 1° ONE PLACE DECIMAL ± .015 TWO PLACE DECIMAL ± .010 THREE PLACE DECIMAL ± .005 INTERPRET GEOMETRIC TOLERANCING PER: MATERIAL FINISH DO NOT SCALE DRAWING	DRAWN JCN CHECKED ENG APPR. MFG APPR. Q.A. PROPRIETARY AND CONFIDENTIAL THE INFORMATION CONTAINED IN THIS DRAWING IS THE SOLE PROPERTY OF REMKE INDUSTRIES. ANY REPRODUCTION IN PART OR AS A WHOLE WITHOUT THE WRITTEN PERMISSION OF REMKE INDUSTRIES IS PROHIBITED.	7/15	TITLE: RSRF-2100-SERIES	
						SIZE A DWG. NO.	RSRF-2100- ASSEMBLY
						SCALE: 1.5:1	SHEET 1 OF 1

5

4

3

2

1