

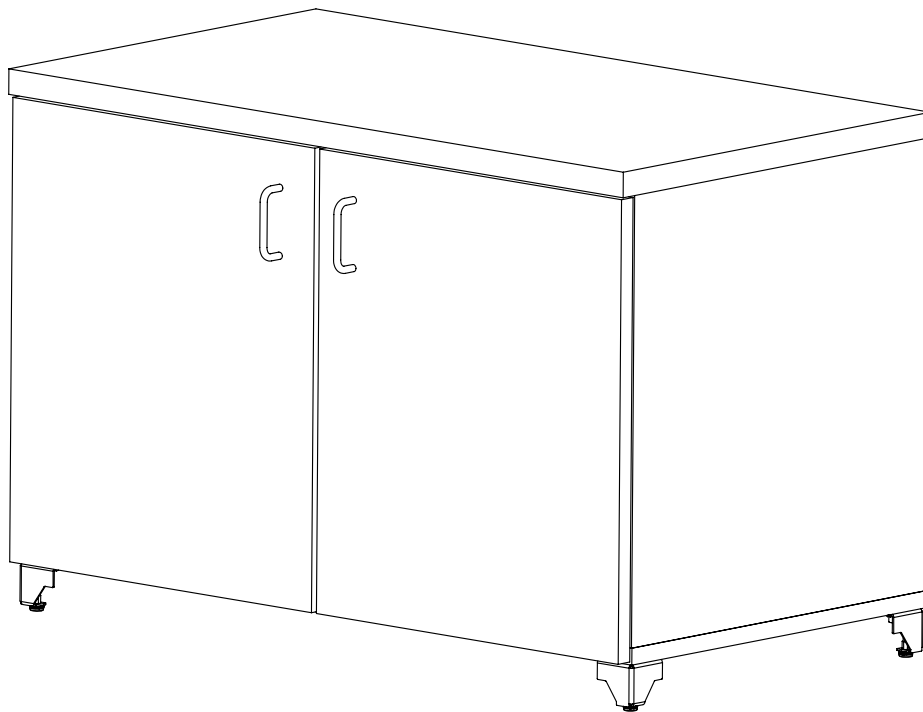

Tevita Casegoods
Lower Door Kit Assembly Instructions



Warranty: raproducts.com/resources/warranty

Tools Required for Assembly

- A. Power Driver with Adjustable Torque
- B. #2 Square Head Driver Bit
- C. #2 Phillips Head Driver Bit (or Phillips screwdriver)

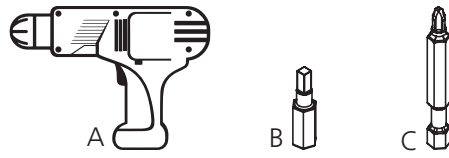

Hardware and Tools Included for Assembly *(may have extra)*

- D. Hinge Screw *x8*
- E. Clear Bumper *x2*
- F. Handle Screw *x4*

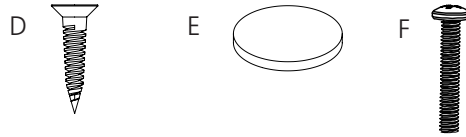

Parts

- G. Hinge *x4*
- H. Hinge Mounting Bracket *x4*
- I. Soft Close Insert *x2*
- J. Handle *x2*
- K. Left Door *x1*
- L. Right Door *x1*

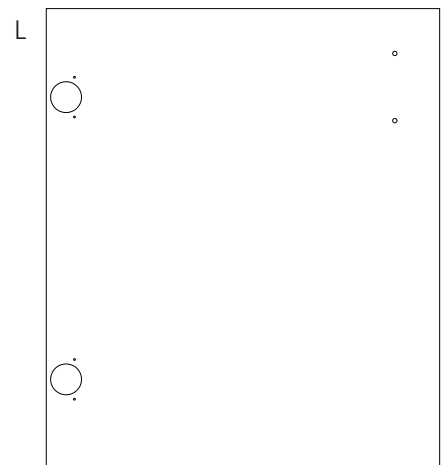
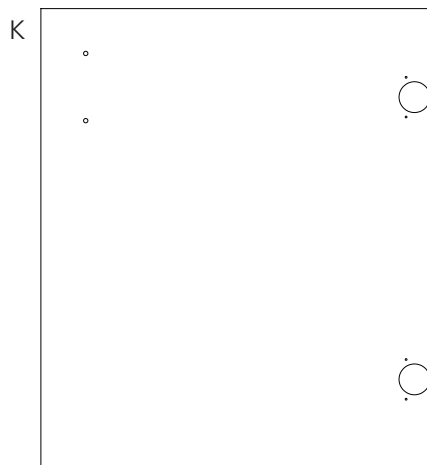
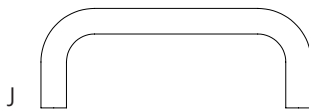
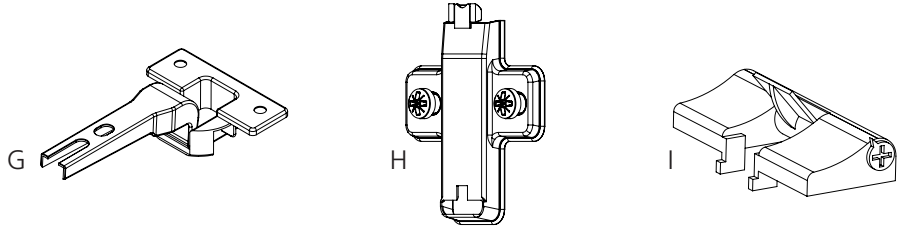

Step 1

- The credenza or vertical storage should already be assembled before installing the lower doors.
- Place the left door (K) on a flat, protective surface with the pre-drilled pilot holes facing upwards.
- Align two hinges (G) with the pre-drilled holes. Secure each hinge (G) using two hinge screws (D).
- Repeat for the right door (L).

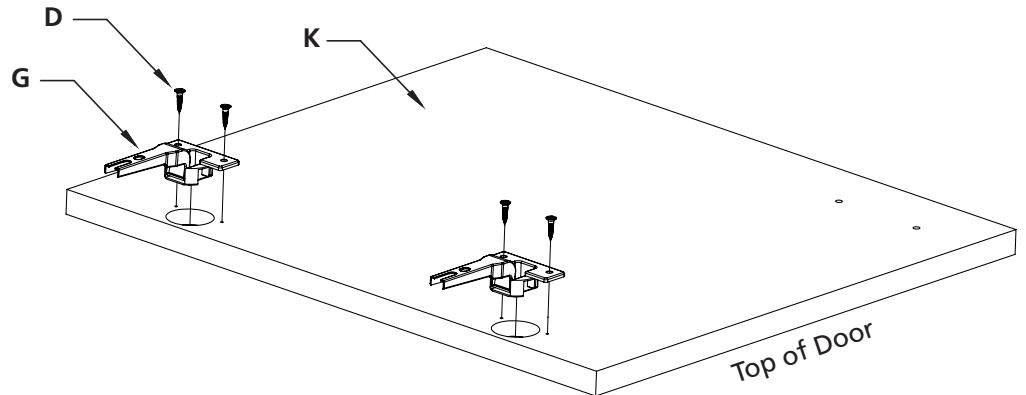
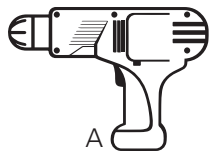

Step 2

- Insert the two tabs on the soft close insert (I) into the two slots inside the hinge (G) that's closest to the top of the left door (J).
- Carefully press down the soft close insert (I) until it snaps into the hinge (G).
- Only one soft close insert will be used per door.
- Repeat for the right door (L).

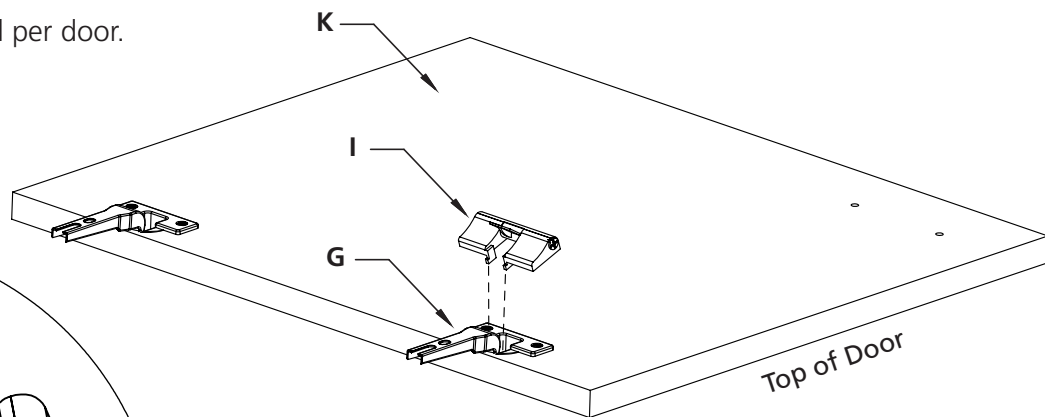
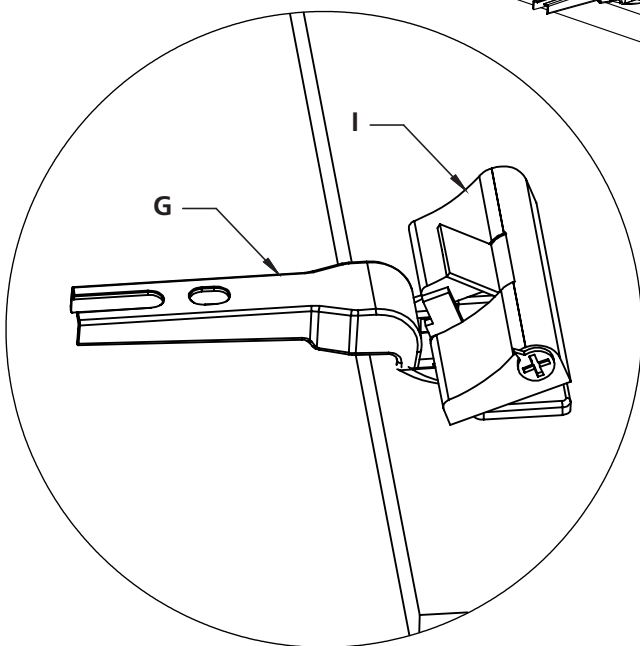

Step 3

- On the left door, align the handle (J) with the pre-drilled holes on the front side of the door.
- Secure the handle to the door using two handle screws (F).
- Repeat for the right door (L).

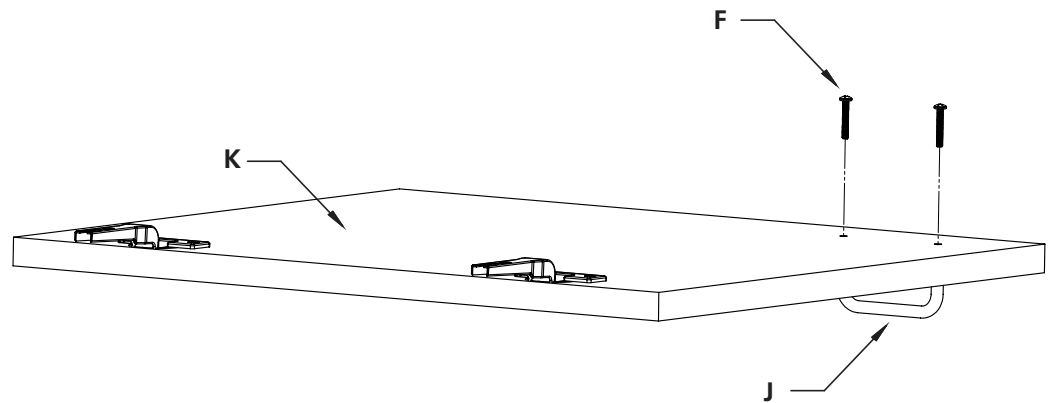
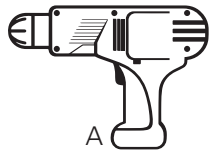

Step 4

- On the left side of the cabinet, align the upper hinge mounting bracket (H) to the pre-drilled holes. There should be one pre-drilled hole above the bracket. Reference the image for clarification.
- Secure the upper hinge mounting brackets (H) to the cabinet. The screws are already attached to the bracket.
- On the same side of the cabinet, align the lower hinge mounting bracket (H) to the pre-drilled holes. There should be one pre-drilled hole below it. Reference the image for clarification.
- Repeat on the right side of the cabinet.

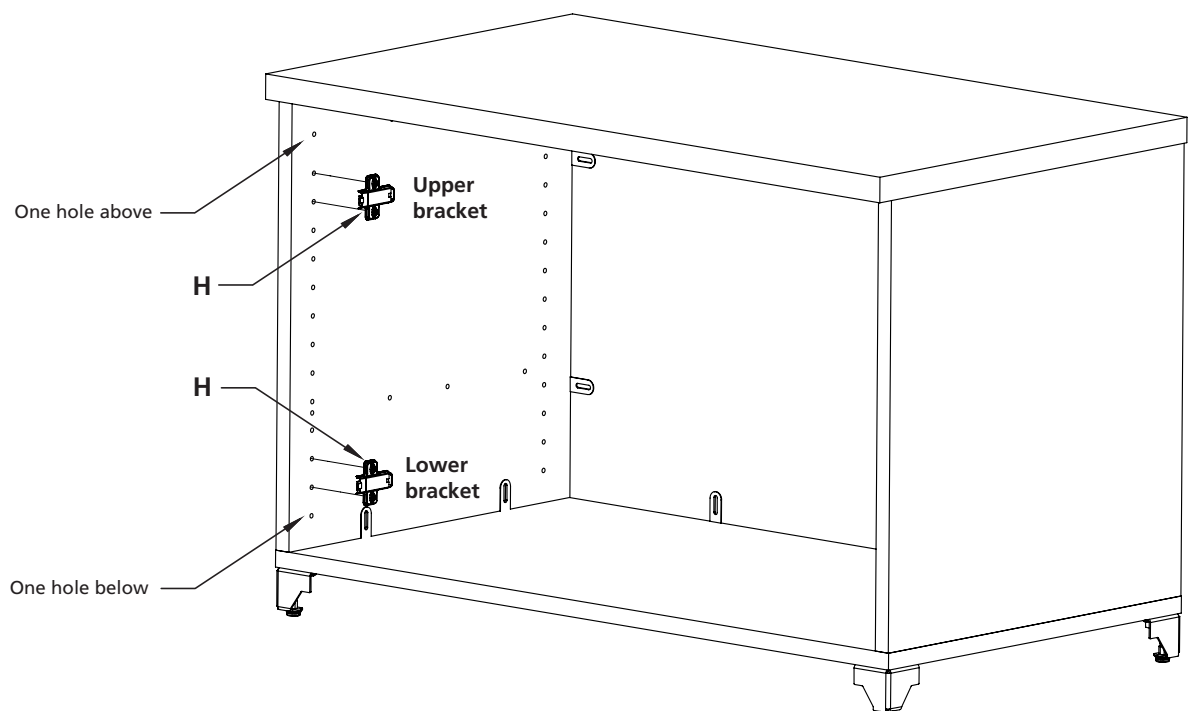
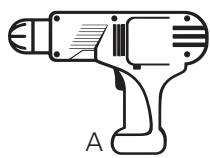

Step 5

- Take the left door (K) and line up the hinges (G) with the hinge mounting brackets (H) on the left side of the cabinet.
- Starting with the top hinge, hook the inner lip of the hinge (G) to the slot at the front of the hinge mounting bracket (H).
- Push the back part of the hinge (G) until it clicks into the back of the hinge mounting bracket (H).
- Follow the same steps for the second hinge on the lower part of the door.
- Repeat this entire step for the right door (L).

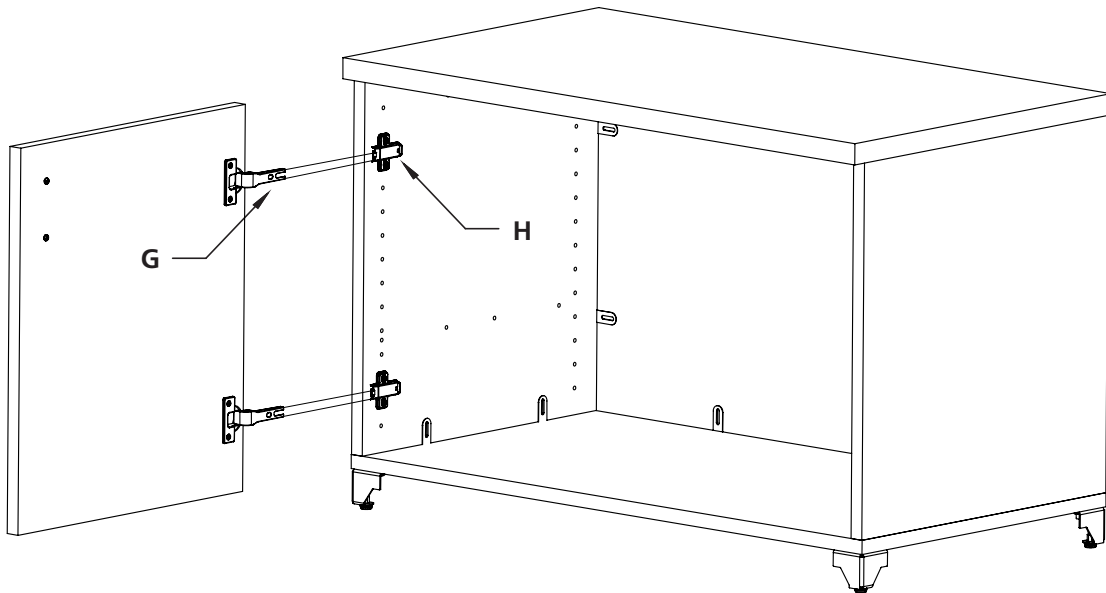

Front of hinge mounting bracket

Inner lip of hinge

Push back of hinge to click into bracket

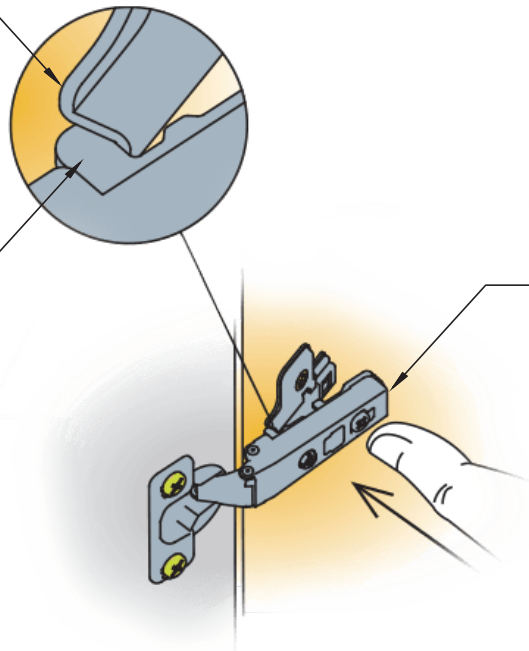

Step 6

- Remove the paper backing from one rubber bumper (E) and place it on the top lefthand corner (near the handle) on the inside of the left door (K).
- Remove the paper backing on another rubber bumper (E), and place it on the top righthand corner (near the handle) on the inside of the right door (L).

