

Metric Threaded Inserts

Design Guide

Threaded Inserts are designed for casting into concrete and providing fixing points for the attachment of structural members and ancillary fittings to be bolted directly to the concrete structure.



Welcome to **reid**TM

ReidTM has been supplying quality engineered products to the New Zealand precast and construction industries for the last 25 years and we have built a position of market leadership in the supply of cast-in components to the concrete construction sector.

ReidTM introduced the revolutionary SwiftLift system, involving robust cast-in anchors and safe, quick release clutches. This unique system greatly increased safety and efficiency in the transportation and placement of large concrete components such as wall panels, stairs, beams and pipes. Reid innovation continued with the development of the ReidBarTM system - ReidBarTM Couplers, Grout Sleeves and Inserts that are used with ReidBarTM - continuously threaded Grade 500E reinforcing steel produced in Australia and New Zealand.

These products are now widely used to enable fast, easy and efficient reinforcement connections on major construction projects throughout all markets. Reid's ongoing commitment to innovation and investment in better products, systems and services was further strengthened when the business became a part of the global ITW Group in 2004. This gives ReidTM people access to significant technology and business resources worldwide, the benefits of which flow to our customers. In partnership with another ITW group member – Ramset, we can deliver lifting, connection, anchorage and fixing solutions for anything built from concrete.

At ReidTM, we aim to be much more than just a supplier of components to the concrete construction industry. We work in partnership with our customers in all facets of planning, preparation, design, engineering, forming, production, rigging, lifting, anchoring and bracing... all critical stages in the safe and efficient manufacture and placement of concrete elements.

Our products help handle the physical load, whilst our professional support services help lift the risk load – each ReidTM design comes backed by the strength of ITW and our absolute commitment to delivering your project faster, safer, more efficiently. This design guide is a practical demonstration of that commitment – we hope you find it useful.

ReidTM Provides:

- **Technical representation in all cities and regional areas**
- **Extensive technical data and support available**
- **Strict quality control systems**
- **Products designed in New Zealand to meet New Zealand Standards**
- **Products tested in New Zealand building materials**
- **Stand behind our product range and performance data**

Contents

Reid™ Threaded Inserts - Overview Using The Design Guide	04-05
Reid™ Threaded Metric Inserts (TIMS) Product information, Technical Data, Installation	06-11
Reid™ 316 Stainless Steel Metric Inserts (TCM) Product information, Technical Data, Installation	12-16
Strength Limit State Design	17-26
Specification & Anchoring Design Worksheet	27-28
BPIR Compliance	29

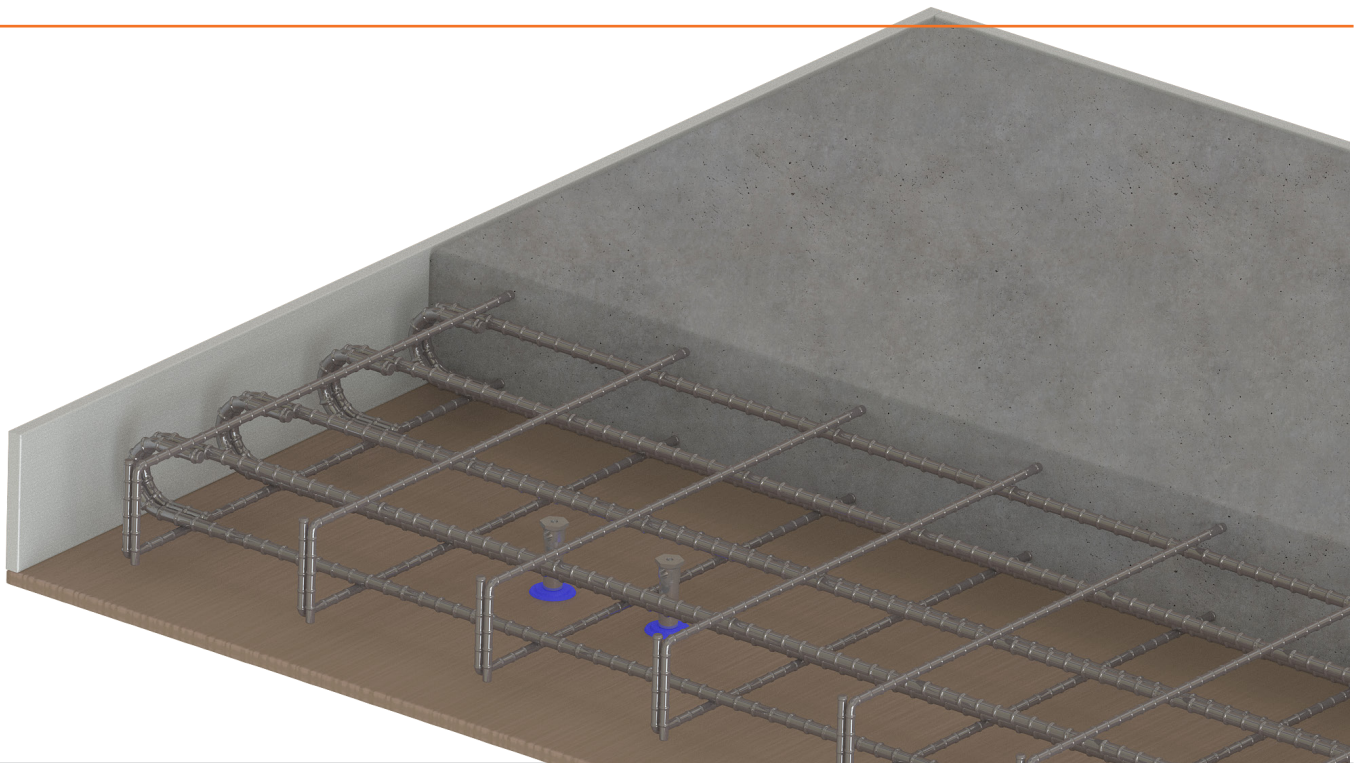

1.1 Threaded Insert Overview



Threaded Inserts are designed for casting into concrete and providing fixing points for the attachment of structural members and ancillary fittings to be bolted directly to the concrete structure. Reid™ supply a range of threaded inserts from M10 to M24 in zinc, hot dipped galvanised and 316 Stainless Steel finishes.

Pre-engineered products such as threaded inserts, require customised application / engineering to devise and deliver the best results for each project. Ultimately this produces value-added solutions for our customer’s needs and inherently better engineering.

The following design information is intended to provide guidance to qualified structural engineers or other suitably skilled persons in the design of cast-in anchors and allows the designer to determine load carrying capacities based on actual application and installation conditions. With the aid of this guide, you have the option to design your cast-in solution independently, or you can easily seek the necessary support from our team of engineers or technical sales professionals. We’re always here to help.



Did you know?



Extensive research, development and testing are invested in Reid™ products. This provides designers with the complete performance capabilities of the Reid range of Cast-In Metric Threaded Inserts.



The performance data contained in this Design Guide relates only to the Reid range of Cast-In Metric Threaded Inserts. Our superior steel grade and manufacturing tolerances are key factors in producing our excellent products.

Generic products may appear similar physically, but their actual performance is heavily influenced by the steel grade and manufacturing tolerances used.



Using The Design Guide

1.2 Using The Design Guide

1.21 STRENGTH LIMIT STATE DESIGN

The Simplified Design Approach to achieve strength limit state design, originally first published by our sister company Ramset, has proven to be a simple and effective method to allow for rapid selection of a suitable anchor through systematic analysis, ensuring that it will meet the required design criteria under strength limit state principles.

1.22 DEVELOPING PULLOUT OF A CONCRETE CONE

The potential to develop a full pullout cone of concrete is assumed in determining the pullout capacity of an insert. Capacity is then modified for factors such as bolt steel strength, concrete strength, spacing to other inserts, or concrete edges that prevent full development of a concrete cone. Tables are provided in the Strength Limit State section of the design guide to calculate these reductions.

1.23 REINFORCEMENT

Reinforcement in the concrete around a threaded insert can affect the concrete pullout and shear capacity. Unless it is specifically designed to work with the insert and enhance its capacity in that situation, reinforcement should always be disregarded when assessing the capacity of the insert during design. For this reason, the design tables provide loadings for inserts in unreinforced concrete without the addition of a hanger bar.

1.24 FORMULAE

Reid traditionally have applied pullout formulae for threaded inserts that have been well established and proven to reliably predict concrete pullout based on the strength of the concrete, location of the insert and the embedment depth. For the new 2023 Design Guide however, we have modified our formula to be consistent in concept with the Concrete Capacity Design (CCD) approach of embedded anchor design that NZS3101 section 17 is modelled on. The CCD approach has its origins in pullout capacity being a function of the square root of the concrete strength whereas the previous Reid pullout formula used concrete strength to the power of two thirds. For the design of the concrete shear capacity we have used NZS3101 section 17 as the basis of design.

1.25 PREVIOUS DOCUMENTATION

The change in formula will supersede any previously published Threaded Insert information from Reid or Ramset. All prior information from Reid or Ramset should be discarded as it is out of date with the publication of this design guide.

1.26 FEEDBACK

We endeavour to provide an accurate and clear document. However, if the information is not clear, inaccurate or you feel that it is misleading, please do not hesitate to contact us to discuss your concerns. We welcome industry feedback.

TIM Product Overview

Reid™ Metric Threaded Inserts (TIM)

Reid™ Threaded Metric Inserts (TIM) are cast into concrete to provide fixing points for attachments and structural members. The TIM is the original Reid design with a large foot at the base of the insert (see nominal dimensions).

All TIM with the exception of the TIM20x120 have a hole through the shaft to accept a hanger bar for situations where full pullout capacity of the TIM is required, e.g. tensile strength limited by shallow embedment or where the TIM is close to an edge.

Features and Benefits

Advantages

- ✓ Easy and simple to use
- ✓ Improved security and reliability for slip free anchorage
- ✓ No cross/hanger required to develop rated capacity
- ✓ Resists dynamic loading
- ✓ Plastic nail plates simplify installation and minimise fouling during the concrete pour

Versatile Applications

- ✓ Medium to heavy duty applications
- ✓ Use in near or far face applications with our range of accessories
- ✓ May be used with small rebar for fixing to mesh
- ✓ Used to provide structural, building service & temporary connections.
- ✓ Curtain wall and panel facades
- ✓ Temporary precast panel bracing points

Finishes & Material

- ✓ High grade carbon steel
- ✓ Gold passivated zinc coating to AS1789:2003 recommended for internal applications
- ✓ Hot Dip Galvanised, recommended for external applications



Application Example



Performance Details (TIM)

Reduced characteristic ultimate bolt shear capacity ϕV_{S2} [kN]**, $\phi = 0.8$



Bolt Size	Suitable Threaded Insert Product Code	Area of Root of thread (mm ²)	Shear **, ϕV_{S2} (kN)	
			Steel Grade of Bolt	
			4.6	8.8
M10	TIM10X40G	52.3	9.8	20.0
M12	TIM12X50G	76.2	14.4	29.3
M16	TIM16X75G	144	27.4	56.1
M20	TIM20X75G / TIM20X120G	225	43.0	88.3
M24	TIM24X100G	324	62.0	127.2



Performance Details (TIM)

Site Installation and Performance Details Reid™ TIM in Uncracked and Unreinforced Concrete

Bolt Size	Product Code	Installation Details			Optimum Dimensions*		Reduced characteristic capacity						
		Cross hole Dia, [mm]	Tightening Torque, T [Nm]	Insert Length (L)	Edge Distance or half distance to another anchor e_c [mm]	Substrate Thickness b_m [mm]	Shear of Grade 8.8 Bolt (No edge Distance) ϕV_{s2} [kN]	Shear, ϕV_{uc} [kN]** towards edge based on optimum dimensions e_c and b_m			Tension, ϕN_{uc} [kN]**		
								Concrete Compressive Strength, f_c			Concrete Compressive Strength, f_c		
								20MPa	30MPa	40MPa	20MPa	30MPa	40MPa
M10	TIM10X40G	9	17	40	60	50	20.0	5.3	6.5	7.5	7.9	9.6	11.1
	***with nail plate							5.6	6.8	7.9	10.6	13.0	15.0
M12	TIM12X50G	9.5	30	50	75	65	29.3	8.0	9.8	11.3	11.4	13.9	16.1
	***with nail plate							8.2	10.1	11.7	14.4	17.6	20.3
M16	TIM16X75G	11.6	75	75	115	95	56.1	17.9	21.9	25.2	21.8	26.6	30.8
	***with nail plate							18.2	22.3	25.8	25.5	31.2	36.1
M20	TIM20X75G	15.5	144	75	115	95	88.3	19.1	23.4	27.0	21.3	26.0	30.1
	***with nail plate							19.1	23.4	27.0	25.0	30.6	35.4
M20	TIM20X120G	N/A	144	120	180	150	88.3	37.3	45.7	52.8	44.8	54.8	63.3
	***with nail plate							37.3	45.7	52.8	49.6	60.8	70.2
M24	TIM24X100G	20.5	250	100	150	125	127.2	28.4	34.8	40.2	33.6	41.2	47.6
	***with nail plate							28.4	34.8	40.2	38.0	46.5	53.7

* Where these minimum dimensions are not achievable, please use the simplified strength limit state design process to verify capacity

**For conversion to Working Load Limit (FOS = 3), MULTIPLY ϕN_{uc} x 0.51 for Tension

**For conversion to Working Load Limit (FOS = 3), MULTIPLY ϕV_{uc} x 0.51 for Shear towards edge

**For conversion to Working Load Limit (FOS = 2.5), MULTIPLY ϕV_{s2} x 0.50 for Shear of Gr 8.8 Bolt

*** Nail Plate set insert 8mm deeper into concrete

Nominal Dimensions (TIM)



Product Codes and Nominal Dimensions Reid Threaded Insert (TIM)

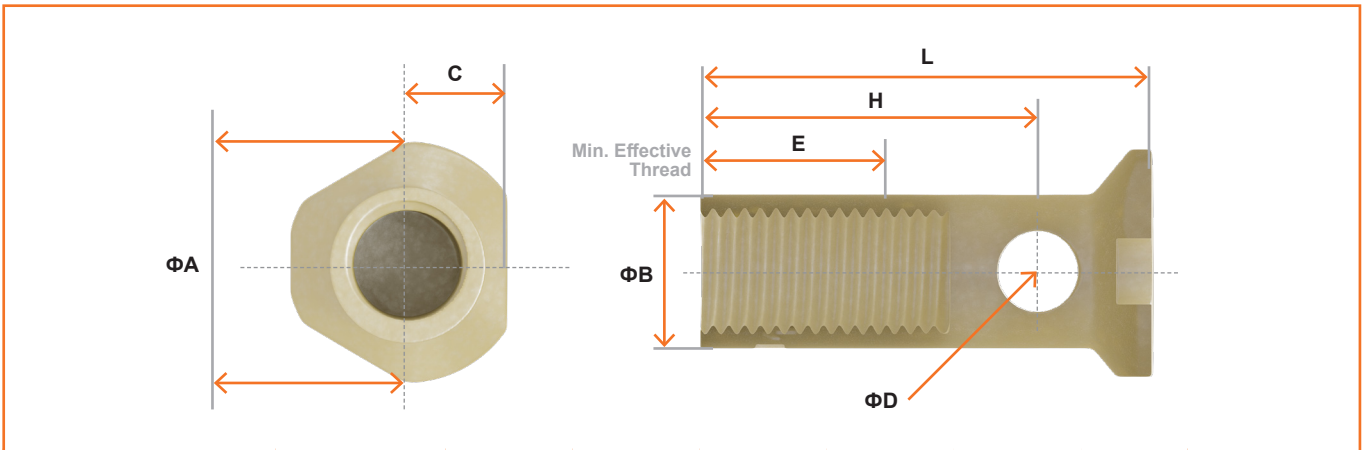

Reid™ Metric Threaded Inserts - Nominal Dimensions (mm)

Metric Threaded Inserts	Insert Length, L [mm]	ΦA	ΦB	C	ΦD	E [min]	H	Thread / Pitch
TIM10X40G	40	25	16	10.6	9	14	25	M10x1.5P
*with nail plate	48							
TIM12X50G	50	28	17	11	9	20	37	M12x1.75P
*with nail plate	58							
TIM16X75 / TIM16X75G	75	39	22	16.6	11	35	55	M16x2P
*with nail plate	83							
TIM20X75 / TIM20X75G	75	53	30	23.5	15.5	32	55	M20x2.5P
*with nail plate	83							
TIM20X120G	120	50	30	N/A	N/A	35	N/A	M20x2.5P
*with nail plate	128							
TIM24X100G	100	60	38	26	20	45	76	M24x3P
*with nail plate	108							

* Nail Plate set insert 8mm deeper into concrete

Metric Threaded Insert Nailing Plates

Product Codes for Metric Nail Plates to suit Reid Threaded Inserts

Product Code	Description	Depth of Nail Plate (mm) (A)	Diameter of Nail Plate (mm) (B)
NP10	Metric Nail Plate M10	8mm	63mm
NP12	Metric Nail Plate M12	8mm	63mm
NP16	Metric Nail Plate M16	8mm	63mm
NP20	Metric Nail Plate M20	8mm	63mm
NP24	Metric Nail Plate M24	8mm	63mm

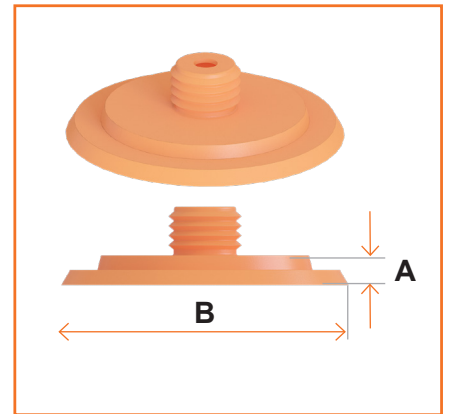

Metric Plastic Glue On Nail Plates

Glue on nailing plates are used to attach ferrules to steel formwork or casting beds, where screwing or drilling is not desired. Designed to be used with Reid Double Sided Spots, they have a recess on the bottom side that allows for easy removal after the panel has been lifted.

Product Code	To Suit	Pack Qty
GP12	M12	100
NP16GLUE	M16	100
GP20	M20	100
GP24	M24	100

Double Sided Spots to Suit:

Product Code	Diam Pack	Pack Qty
NPSPT	58mm	100



Material Properties (TIM)

Engineering Properties Reid™ Threaded Insert (TIM)

Size	Product Code	Min. stress area of anchor, A_s (mm ²)	Bearing area of head of insert, A_{brg} (mm ²)	Carbon Steel *	
				Yield Strength f_y (MPa)	UTS, f_u (MPa)
M10	TIM10X40G	65.0	237.4	240	400
M12	TIM12X50G	81.4	247.5	240	400
M16	TIM16X75G	127.8	696.4	240	400
M20	TIM20X75G	263.4	1350.6	240	400
M20	TIM20X120G	263.4	1350.6	370**	600**
M24	TIM24X100G	410.8	1450.5	240	400

* Mechanical Properties of Carbon Steel for all sizes except TIM20x120.

** Mechanical Properties of TIMx120 is based on SG IRON QT 600-3.

Installation Instructions (TIM)

- Either insert a positioning bolt through the mould wall or boxing and thread the insert onto the bolt until flush with the wall, or thread the insert onto a nail plate and fix this to the mould.
- If required, pass a rebar of the correct diameter and length through the cross-hole in the insert and tie to the reinforcement to prevent it moving during pouring and vibration of the concrete.
- When the concrete has cured, remove the bolt and mould. If a nailing plate has been used leave it screwed into the insert until immediately before use to help protect the internal thread.

Limitations

- Structural capacity is dependent upon the load capacity required, or the diameter of the fixing bolt selected.
- Remember the practical aspect: small diameter inserts are much more prone to fouling and thread damage than larger inserts. For most applications it is preferable to use inserts of M12 diameter or greater.

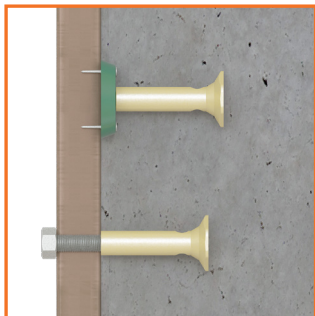

1. Nailing plate or bolted to formwork



2. Fixing to steel casting bed with glue-on nailing plate



3. "Puddled" into wet concrete



4. Templated onto face of panel

TCM Product Overview

Reid™ 316 Stainless Steel Metric Threaded Inserts (TCM)

The Reid™ Stainless Steel Metric Threaded Inserts (TCM) are manufactured from premium grade 316 Stainless Steel and suit medium to heavy duty structural applications. Noticably different from the TMS, this threaded insert has an Elephant Foot™.

All TCMs have a hole through the shaft to accept a hanger bar for situations where full pullout capacity of the TCMs is required. e.g. tensile strength limited by shallow embedment or where the TCM is close to an edge.

Features and Benefits

Advantages

- ✔ Easy and simple to use
- ✔ Improved security and reliability for slip free anchorage
- ✔ No cross/hanger bar required to develop rated capacity
- ✔ Resists dynamic loading
- ✔ Plastic nail plates simplify installation and minimise fouling during the concrete pour

Versatile Applications

- ✔ Suitable for use in corrosive areas where durability is required such as salt spray zones
- ✔ Use in near or far face applications with our range of accessories
- ✔ May be used with small rebar for fixing to mesh
- ✔ Used to provide structural, building service & temporary connections.
- ✔ Curtain wall and panel facades
- ✔ Temporary precast panel bracing points

Finishes

- ✔ AISI 316 Stainless Steel suitable for marine or corrosive environments

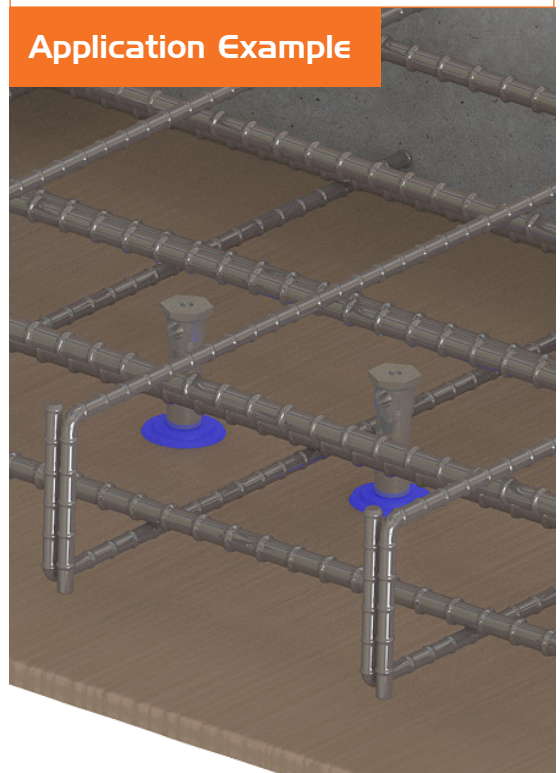

Performance Details (TCM)

Reduced characteristic ultimate bolt shear capacity ϕV_{s2} [kN]**, $\phi = 0.8$



Bolt Size	Suitable Threaded Insert Product Code	Area of Root of thread (mm ²)	Shear, ϕV_{s2} (kN)
			Steel Grade of Bolt
			AISI 316 Stainless Steel
M10	FE10045SS	52.3	16.8
M12	FE12055SS	76.2	24.7
M16	FE16070SS	144	47.4
M20	FF20095SS	225	74.5



Site Installation and Performance Details 316 Stainless Steel FE in Uncracked and Unreinforced Concrete

Bolt Size	Product Code	Installation Details			Optimum Dimensions*		Reduced characteristic capacity						
		Cross hole Dia, [mm]	Tightening Torque, T [Nm]	Insert Length (L)	Edge Distance or half distance to another anchor e_c [mm]	Substrate Thickness b_m [mm]	Shear For AISI 316 SS Bolt (No edge Distance) ϕV_{s2} [kN]	Shear, ϕV_{uc} [kN]** towards edge based on optimum dimensions e_c and b_m			Tension, ϕN_{uc} [kN]**		
								Concrete Compressive Strength, f_c			Concrete Compressive Strength, f_c		
								20MPa	30MPa	40MPa	20MPa	30MPa	40MPa
M10	FE10045SS	8.4	17	45	60	50	16.8	5.5	6.7	7.7	9.5	11.6	13.4
	***with nail plate							5.7	7.0	8.0	12.5	15.3	17.7
M12	FE12055SS	8.4	30	55	75	65	24.7	8.1	10.0	11.5	13.3	16.2	18.7
	***with nail plate							8.4	10.3	11.9	16.5	20.2	23.3
M16	FE16070SS	14.5	75	70	100	85	47.4	13.9	17.0	19.6	19.5	23.9	27.6
	***with nail plate							14.2	17.4	20.1	23.1	28.3	32.7
M20	FE20095SS	14.5	144	95	135	115	74.5	23.9	29.2	33.7	31.0	38.0	43.8
	***with nail plate							24.2	29.7	34.3	35.3	43.2	49.9

* Where these minimum dimensions are not achievable, please use the simplified strength limit state design process to verify capacity

**For conversion to Working Load Limit (FOS = 3), MULTIPLY ϕN_{uc} x 0.51 for Tension

**For conversion to Working Load Limit (FOS = 3), MULTIPLY ϕV_{uc} x 0.51 for Shear towards edge

**For conversion to Working Load Limit (FOS = 2.5), MULTIPLY ϕV_{s2} x 0.50 for Shear of AISI 316 SS Bolt

*** Nail Plate set insert 8mm deeper into concrete

Nominal Dimensions (TCM)



Product Codes and Nominal Dimensions Reid Threaded Insert (TCM)

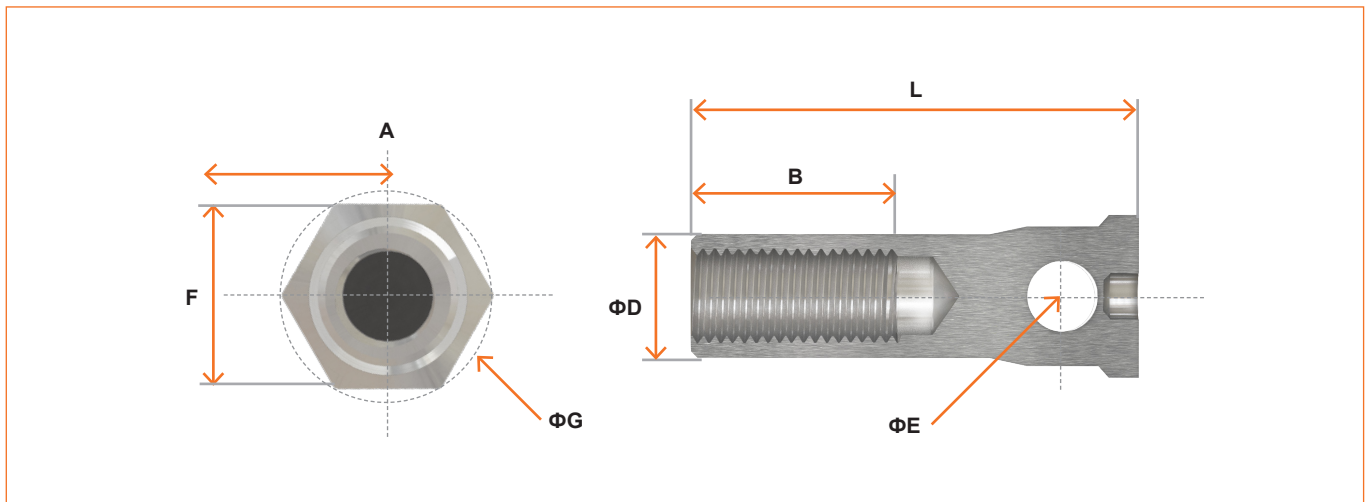

REID METRIC THREADED INSERTS - NOMINAL DIMENSIONS [mm]								
REID Metric Threaded Inserts	Insert Length, L [mm]	A	B	ΦD	ΦE	F	ΦG	Thread / Pitch
FE10045SS	45	M10	20	16	8.4	19.0-19.3	20.9	M10x1.5P
*with nail plate	53							
FE12055SS	55	M12	25	17	8.4	22.0-22.3	24.4	M12x1.75P
*with nail plate	63							
FE16070SS	70	M16	32	22	14.5	31.8	35.0	M16x2P
*with nail plate	78							
FE20095SS	95	M20	38	26	14.5	34.5	37.0	M20x2.5P
*with nail plate	103							

* Nail Plate set insert 8mm deeper into concrete

Product Codes for Metric Nail Plates to suit Reid Threaded Inserts

Product Codes	Description	Depth of Nail Plate (mm) (A)	Diameter of Nail Plate (mm) (B)
NP10	Metric Nail Plate M10	8	63
NP12	Metric Nail Plate M12	8	63
NP16	Metric Nail Plate M16	8	63
NP20	Metric Nail Plate M20	8	63
NP24	Metric Nail Plate M24	8	63

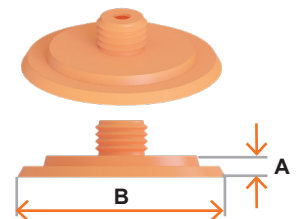

Note: 'Stick-on' nail plates available to suit most sizes. Refer to 'Metric Plastic Glue-On Nail Plate' table on Page 10 for further details.

Material Properties (TCM)

Engineering Properties Reid Threaded Insert (TCM)

Bolt Size	Product Code	Min.stress area of anchor, A_s (mm ²)	AISI 316 Stainless Steel	
			Yield strength, f_y (MPa)	UTS, f_u (MPa)
M10	FE10045SS	71.3	450	700
M12	FE12055SS	88.3	450	700
M16	FE16070SS	158.0	450	600
M20	FE20095SS	242.0	450	600

Installation Instructions (TCM)

- Either insert a positioning bolt through the mould wall or boxing and thread the insert onto the bolt until flush with the wall, or thread the insert onto a nail plate and fix this to the mould.
- If required, pass a rebar of the correct diameter and length through the cross-hole in the insert and tie to the reinforcement to prevent it moving during pouring and vibration of the concrete.
- When the concrete has cured, remove the bolt and mould. If a nailing plate has been used leave it screwed into the insert until immediately before use to help protect the internal thread.

Limitations

- Structural capacity is dependent upon the load capacity required, or the diameter of the fixing bolt selected.
- Remember the practical aspect: small diameter inserts are much more prone to fouling and thread damage than larger inserts. For most applications it is preferable to use inserts of M12 diameter or greater.

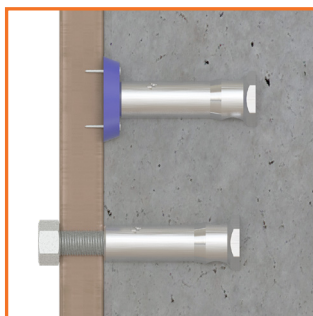

1. Nailing plate or bolted to formwork



2. Fixing to steel casting bed with glue-on nailing plate



3. "Puddled" into wet concrete



4. Templated onto face of panel

Strength Limit State Design

Step I. Select Anchor to be Evaluated

Diagram Table 1A-1 Indicative combined loading with no edge or spacing effects, e_m (mm) (TIM)

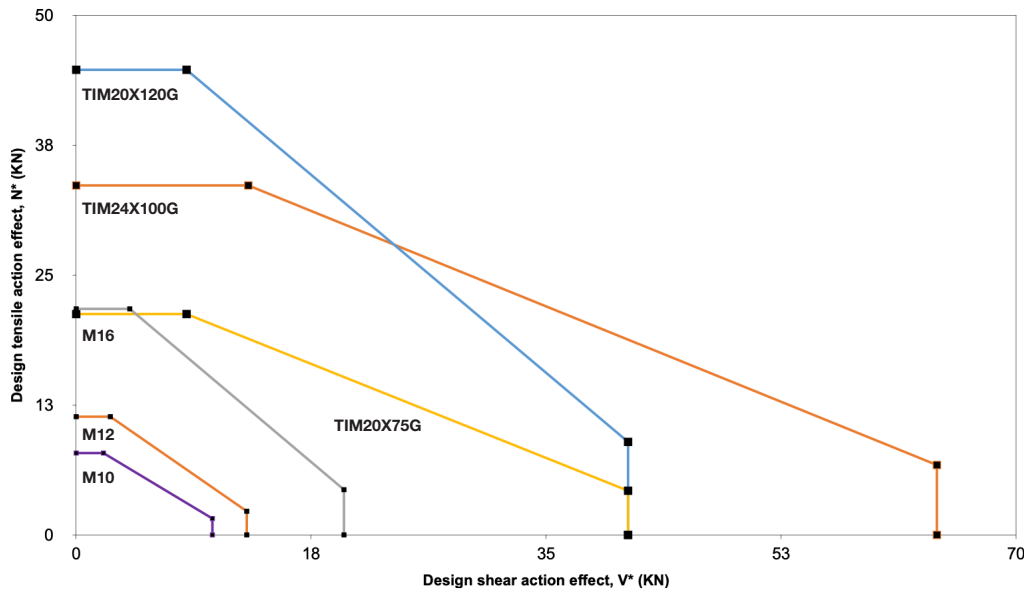

- TIM10X40G
- TIM12X50G
- TIM16X75G
- TIM20X75G
- TIM20X120G
- TIM24X100G

Notes:

1. Tension limited by the lesser of steel capacity and concrete cone capacity. No edge or spacing effects.
2. Shear limited by the TIM capacity
3. $f_c = 20$ MPa
4. Without Nail Plate

Diagram Table 1A-2 Indicative combined loading with no edge or spacing effects, e_m (mm) (TCM 316SS)

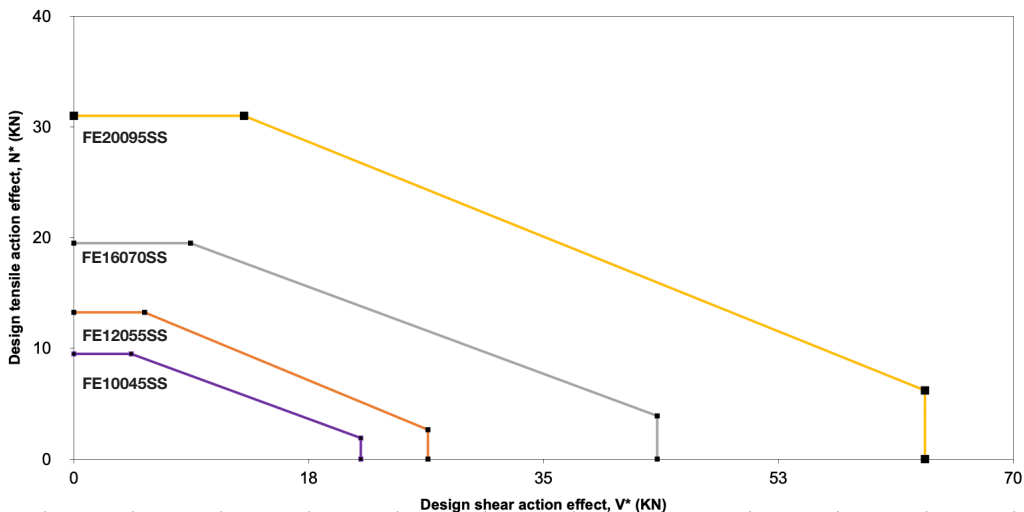

- FE10045SS
- FE12055SS
- FE16070SS
- FE20095SS

Notes:

1. Tension limited by the lesser of steel capacity and concrete cone capacity. No edge or spacing effects.
2. Shear limited by the TCM capacity.
3. $f_c = 20$ MPa
4. Without Nail Plate.

Table 1A Absolute minimum edge distance and half of anchor spacing values, e_m (mm)

Product Code	TIM10X40G FE10045SS	TIM12X50G FE12055SS	TIM16X75G FE16070SS	TIM20X75G FE20095SS	TIM20X120G	TIM24X100G
e_m , mm	30	36	48	60	85	72



Anchor Size, Absolute Minima Compliance Achieved

Step 2. Verify Concrete Tensile Capacity ϕN_{URC} (per anchor)

Table 2A Reduced characteristic ultimate concrete tensile capacity, ϕN_{uc} (kN), $\phi = 0.65$, $f'c = 20$ MPa

Product Code	TIM10X40G	TIM12X50G	TIM16X75G	TIM20X75G	TIM20X120G	TIM24X100G
ϕN_{uc} [kN]	7.9	11.4	21.8	21.3	44.8	33.6
with nail plate	10.6	14.4	25.5	25.0	49.6	38.0

Product Code	FE10045SS	FE12055SS	FE16070SS	FE20095SS
ϕN_{uc} [kN]	9.5	13.3	19.5	31.0
with nail plate	12.5	16.5	23.1	35.3

Table 2B-1 Cracked concrete effect, tension, ψ_{ncr}

Product Code	TIM10X40G	TIM12X50G	TIM16X75G	TIM20X75G	TIM20X120G	TIM24X100G
ψ_{ncr}	0.8					

Product Code	FE10045SS	FE12055SS	FE16070SS	FE20095SS
ψ_{ncr}	0.8			

Table 2B-1 Note: For Non-cracked concrete at service load level $\psi_{ncr} = 1.0$

Table 2B-2 Concrete compressive strength effect, tension, ψ_{nc}

$f'c$ [MPa]	15	20	25	30	40	50
ψ_{nc}	0.87	1	1.12	1.22	1.41	1.58

Diagram 2 Edge and spacing effect, tension, $X = \phi_{x_1} * \phi_{x_2} * \phi_{y_1} * \phi_{y_2}$

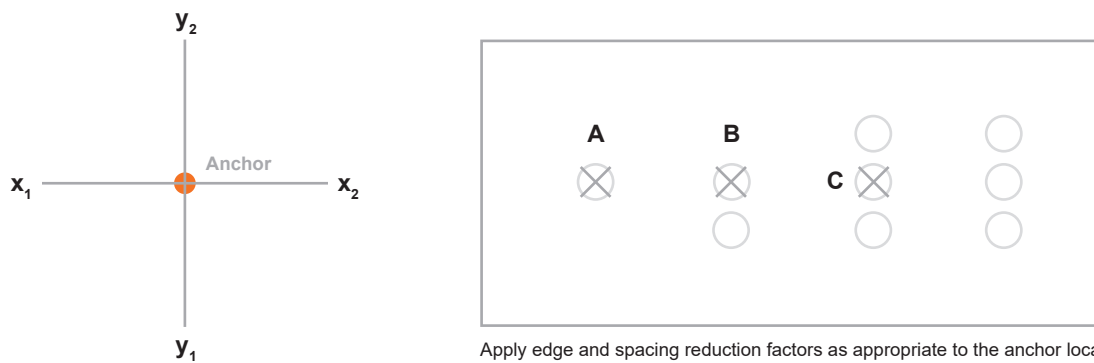

Examples

Anchor →	A		B		C	
Factor	Type	Table	Type	Table	Type	Table
ϕ_{x_1}	Edge	2C	Spacing	2D	Spacing	2D
ϕ_{x_2}	Spacing	2D	Spacing	2D	Spacing	2D
ϕ_{y_1}	Edge	2C	Spacing	2D	Spacing	2D
ϕ_{y_2}	Edge	2C	Edge	2C	Spacing	2D

If edge distance to anchor greater than 1.5 times effective depth then reduction factor = 1.0.
 If anchor spacing greater than 3 times effective depth then reduction factor = 1.0.

Table 2C Edge distance reduction factor ϕ_{ex} and ϕ_{ey}

Product Code	Anchor Edge Distance, e (mm)									
	30	40	50	60	70	85	100	125	150	>200
TIM10X40G *with nail plate	0.74 0.69	0.84 0.77	0.95 0.85	1.00 0.94	1.00 1.00	1.00 1.00	1.00 1.00	1.00 1.00	1.00 1.00	1.00 1.00
TIM12X50G *with nail plate		0.75 0.71	0.83 0.77	0.92 0.84	1.00 0.91	1.00 1.00	1.00 1.00	1.00 1.00	1.00 1.00	1.00 1.00
TIM16X75G *with nail plate			0.70 0.67	0.74 0.72	0.79 0.76	0.87 0.83	0.96 0.90	1.00 1.00	1.00 1.00	1.00 1.00
TIM20X75G *with nail plate			0.70 0.68	0.75 0.72	0.80 0.76	0.88 0.83	0.97 0.91	1.00 1.00	1.00 1.00	1.00 1.00
TIM20X120G *with nail plate						0.71 0.69	0.75 0.73	0.83 0.81	0.92 0.88	1.00 1.00
TIM24X100G *with nail plate					0.71 0.69	0.76 0.74	0.82 0.79	0.92 0.88	1.00 0.98	1.00 1.00

316 Stainless Steel Inserts (TCM)

FE100145SS *with nail plate	0.71 0.67	0.79 0.73	0.88 0.81	1.00 0.97	1.00 1.00	1.00 1.00	1.00 1.00	1.00 1.00	1.00 1.00	1.00 1.00
FE12055SS *with nail plate		0.72 0.69	0.79 0.75	0.87 0.81	0.95 0.87	1.00 0.97	1.00 1.00	1.00 1.00	1.00 1.00	1.00 1.00
FE16070SS *with nail plate			0.72 0.69	0.77 0.73	0.82 0.78	0.91 0.86	1.00 0.94	1.00 1.00	1.00 1.00	1.00 1.00
FE20095SS *with nail plate			0.65 0.64	0.68 0.67	0.72 0.70	0.78 0.75	0.84 0.81	0.95 0.91	1.00 1.00	1.00 1.00

Table 2D Anchor spacing distance reduction factor ϕ_{sx} and ϕ_{sy}

Product Code	Anchor spacing, a (mm)													
	30	40	50	60	70	85	100	125	150	200	250	300	350	>400
TIM10X40G *with nail plate	0.64 0.61	0.69 0.65	0.73 0.69	0.78 0.73	0.82 0.77	0.89 0.82	0.96 0.88	1.00 0.97	1.00 1.00	1.00 1.00	1.00 1.00	1.00 1.00	1.00 1.00	1.00 1.00
TIM12X50G *with nail plate		0.64 0.62	0.68 0.65	0.72 0.69	0.75 0.72	0.81 0.76	0.86 0.81	0.95 0.89	1.00 0.96	1.00 1.00	1.00 1.00	1.00 1.00	1.00 1.00	1.00 1.00
TIM16X75G *with nail plate			0.62 0.61	0.64 0.63	0.67 0.65	0.70 0.68	0.74 0.71	0.80 0.77	0.86 0.82	0.98 0.93	1.00 1.00	1.00 1.00	1.00 1.00	1.00 1.00
TIM20X75G *with nail plate			0.62 0.61	0.64 0.63	0.67 0.65	0.70 0.68	0.74 0.71	0.80 0.77	0.86 0.82	0.98 0.93	1.00 1.00	1.00 1.00	1.00 1.00	1.00 1.00
TIM20X120G *with nail plate						0.62 0.62	0.64 0.64	0.68 0.67	0.72 0.70	0.76 0.74	0.85 0.82	0.94 0.90	1.00 0.99	1.00 1.00
TIM24X100G *with nail plate					0.62 0.61	0.65 0.64	0.68 0.66	0.72 0.70	0.76 0.74	0.85 0.82	0.94 0.90	1.00 0.99	1.00 1.00	1.00 1.00

316 Stainless Steel Threaded Inserts (TCM)

FE100145SS *with nail plate	0.62 0.60	0.66 0.64	0.70 0.67	0.74 0.70	0.78 0.74	0.85 0.79	0.91 0.84	1.00 0.93	1.00 1.00	1.00 1.00	1.00 1.00	1.00 1.00	1.00 1.00	1.00 1.00
FE12055SS *with nail plate		0.63 0.61	0.66 0.64	0.70 0.67	0.73 0.70	0.78 0.74	0.83 0.78	0.91 0.85	0.99 0.92	1.00 1.00	1.00 1.00	1.00 1.00	1.00 1.00	1.00 1.00
FE16070SS *with nail plate			0.63 0.61	0.65 0.64	0.68 0.66	0.71 0.69	0.75 0.73	0.82 0.78	0.88 0.84	1.00 0.95	1.00 1.00	1.00 1.00	1.00 1.00	1.00 1.00
FE20095SS *with nail plate			0.59 0.59	0.61 0.60	0.63 0.62	0.66 0.64	0.68 0.67	0.73 0.71	0.77 0.76	0.87 0.84	0.96 0.93	1.00 1.00	1.00 1.00	1.00 1.00

Verify Concrete Tension Capacity

Computation 2E Complete the table and determine, X as the product of the factors

Factor	Type	Table	Value
ϕ_{x_1}			
ϕ_{x_2}			
ϕ_{y_1}			
ϕ_{y_2}			
Factor X product of factors			



Checkpoint 2

Determine the reduced ultimate concrete tensile capacity of the anchor situation ϕN_{urc}

$$\phi N_{urc} = \phi N_{uc} * \psi_{ncr} * \psi_{nc} * X$$

Step 3. Verify Steel Tensile Capacity, ϕN_{us} (kN) (per anchor)

Table 3A Reduced characteristic ultimate anchor steel capacity, ϕN_{us} (kN), $\phi = 0.75$

Product Code	TIM10X40G	TIM12X50G	TIM16X75G	TIM20X75G	TIM20X120G	TIM24X100G
ϕN_{us} [kN]	19.5	24.4	38.3	79.0	79.0	123.2

Product Code	FE10045SS	FE12055SS	FE16070SS	FE20095SS
ϕN_{us} [kN]	37.3	46.3	71.1	108.9

Table 3B Reduced characteristic ultimate bolt tensile capacity, ϕN_{TF} (kN), $\phi_n = 0.8$

Bolt Size	M10		M12		M16		M20		M24	
ϕN_{TF} [kN]	G4.6	G8.8	G4.6	G8.8	G4.6	G8.8	G4.6	G8.8	G4.6	G8.8
	18.6	38.5	27	56	50.2	104.2	78.4	162.7	112.8	234.4

Bolt Size AISI 316 SS	M10	M12	M16	M20
ϕN_{TF} [kN]	32.5	47.2	87.9	137.2

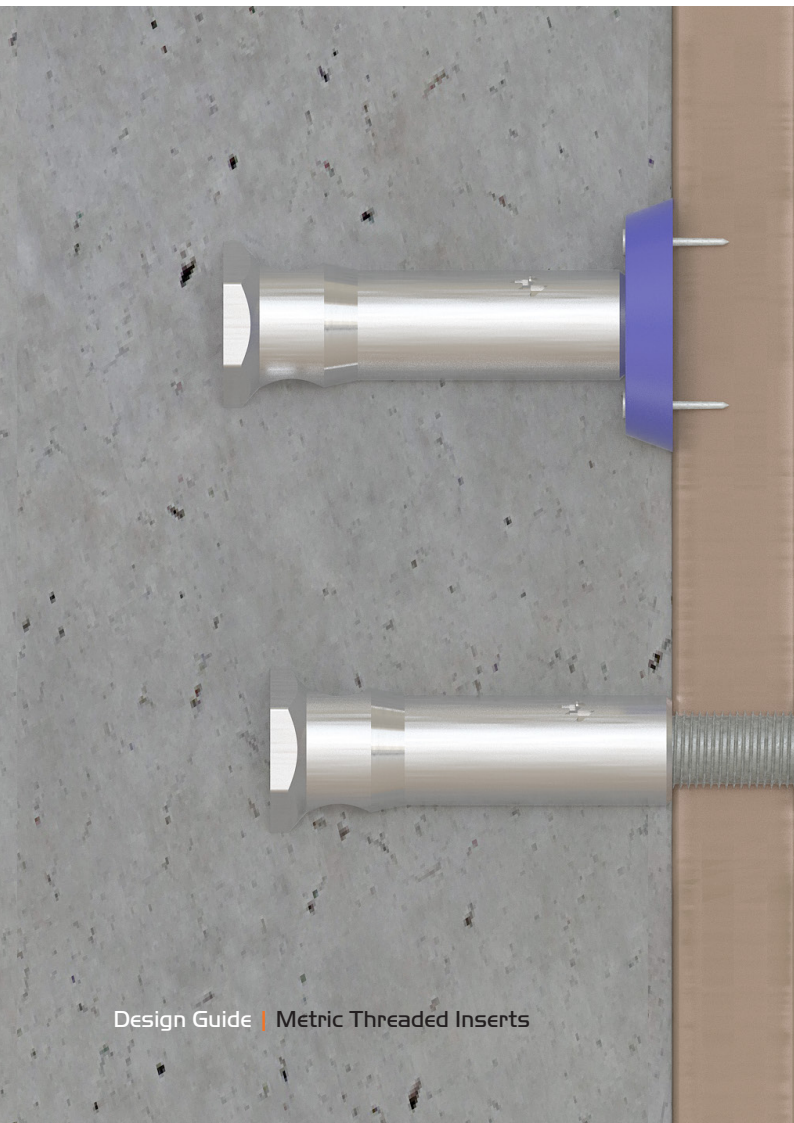

Verify Steel Tension Capacity

Step 3 Establish the reduced characteristic bolt tensile capacity, from the literature of the specified bolt manufacturer. Table 3B details the nominal expected capacities of bolts manufactured to ISO standards.

Checkpoint 3

Design reduced ultimate tensile capacity, ϕN_{ur} (kN)

$$\phi N_{ur} = \text{Minimum of } \phi N_{urc}, \phi N_{us}, \phi N_{TF}$$

$$\text{Check } N^* / \phi N_{ur} \leq 1,$$

If not satisfied return to Step 1

Step 4. Verify Concrete Shear Capacity (per anchor) Perpendicular to Edge, ϕV_{CB} (kN), $\phi = 0.65$

Anchor Shear Capacity (reference NZS3101 Section 17)

Table 4A Reduced basic concrete breakout strength in Shear, per anchor ϕV_b (kN), for single anchor $\phi = 0.65 f_c = 20\text{MPa}$

Product Code	c1 - distance from the centre of resistance of an anchor to the edge of the concrete in the direction which the load is applied, mm											
	30	35	40	50	60	85	100	200	300	400	500	≥ 600
TIM10X40G *with nail plate	1.9 2.0	2.4 2.5	2.9 3.0	4.1 4.2	5.3 5.6	9.0 9.4	11.5 12.0	32.5 33.8	59.7 62.1	91.9 95.7	128.4 133.7	168.8 175.7
TIM12X50G *with nail plate		2.5 2.6	3.1 3.2	4.3 4.5	5.7 5.9	9.6 9.9	12.3 12.7	34.7 35.9	63.8 65.9	98.3 101.5	137.4 141.8	180.6 186.4
TIM16X75G *with nail plate				5.1 5.2	6.7 6.9	11.3 11.6	14.5 14.8	40.9 41.8	75.2 76.8	115.8 118.3	161.9 165.4	212.8 217.4
TIM20X75G *with nail plate					7.2 5.4	12.1 9.1	15.5 11.6	43.7 32.7	80.4 60.1	123.7 92.5	172.9 129.3	227.3 170.0
TIM20X120G *with nail plate						12.1 12.1	15.5 15.5	43.7 43.7	80.4 80.4	123.7 123.7	172.9 172.9	227.3 227.3
TIM24X100G *with nail plate						12.1 12.1	15.5 15.5	43.7 43.7	80.4 80.4	123.7 123.7	172.9 172.9	227.3 227.3

316 Stainless Steel Threaded Inserts (TCM)

FE100145SS *with nail plate	1.9 2.0	2.4 2.5	3.0 3.1	4.2 4.3	5.5 5.7	9.2 9.6	11.8 12.2	33.3 34.6	61.3 63.5	94.3 97.7	131.8 136.6	173.3 179.6
FE12055SS *with nail plate		2.6 2.7	3.2 3.3	4.4 4.6	5.8 6.0	9.8 10.1	12.5 12.9	35.5 36.5	65.2 67.1	100.3 100.3	140.2 144.4	184.3 189.8
FE16070SS *with nail plate			3.5 3.6	4.9 5.0	6.4 6.6	10.9 11.1	13.9 14.2	39.2 40.1	72.0 73.7	110.9 113.5	155.0 158.6	203.8 208.5
FE20095SS *with nail plate					7.1 7.2	11.9 12.1	15.2 15.4	43.0 43.7	79.1 80.2	121.7 123.5	170.1 172.6	223.6 226.9

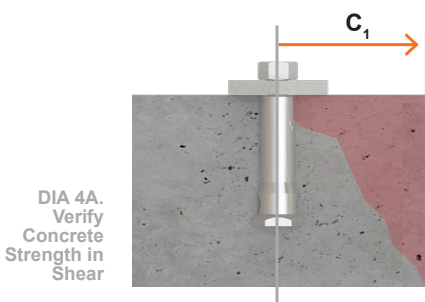

Table 4B-1 Cracked concrete effect, shear, ψ_{vcr}

Product Code	TIM-10X40G	TIM-12X50G	TIM-16X75G	TIM-20X75G	TIM-20X120G	TIM-24X100G
ψ_{vcr}	0.7					
Product Code	FE10045SS	FE12055SS	FE16070SS	FE20095SS		
ψ_{vcr}	0.7					

Note: For Non-cracked concrete at service load level $\psi_{vcr} = 1$

Table 4B-2 Concrete compressive strength effect, shear, ψ_{vc}

f_c [MPa]	15	20	25	≥ 30
ψ_{ncr}	0.87	1	1.12	1.22

Table 4C Modification factor for anchor groups, ψ_s (if $e_v <$ half of centre-to-centre spacing, s)

e_v -distance between the point of shear application and the centroid of the group of anchors resisting the shear in direction of the applied shear	C_1 - distance from the centre of resistance of an anchor to the edge of the concrete in the direction which the load is applied, mm												
	#	30	35	40	50	60	85	100	200	300	400	500	600
0	1.00	1.00	1.00	1.00	1.00	1.00	1.00	1.00	1.00	1.00	1.00	1.00	1.00
40	0.53	0.57	0.60	0.65	0.69	0.76	0.79	0.88	0.92	0.94	0.95	0.96	
80	0.36	0.40	0.43	0.48	0.53	0.61	0.65	0.79	0.85	0.88	0.90	0.92	
120	0.27	0.30	0.33	0.38	0.43	0.52	0.56	0.71	0.79	0.83	0.86	0.88	
160	0.22	0.25	0.27	0.32	0.36	0.44	0.48	0.65	0.74	0.79	0.82	0.85	
200	0.18	0.21	0.23	0.27	0.31	0.39	0.43	0.60	0.69	0.75	0.79	0.82	
240	0.16	0.18	0.20	0.24	0.27	0.35	0.38	0.56	0.65	0.71	0.76	0.79	
280	0.14	0.16	0.18	0.21	0.24	0.31	0.35	0.52	0.62	0.68	0.73	0.76	
320	0.12	0.14	0.16	0.19	0.22	0.28	0.32	0.48	0.58	0.65	0.70	0.74	

Diagram 4C Distance half of centre-to-centre spacing

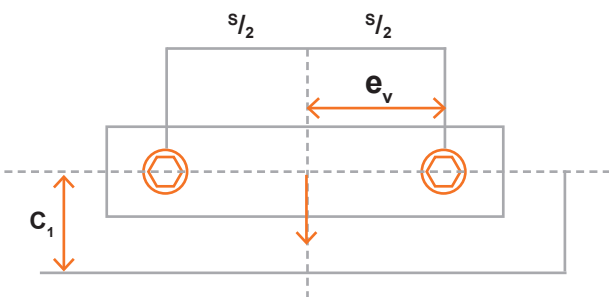

A cross hole through the shaft is provided to accept a hanger bar for situations where full pullout capacity of the fitting is required (eg: tensile strength limited by shallow embedment or where the fitting is close to an edge)

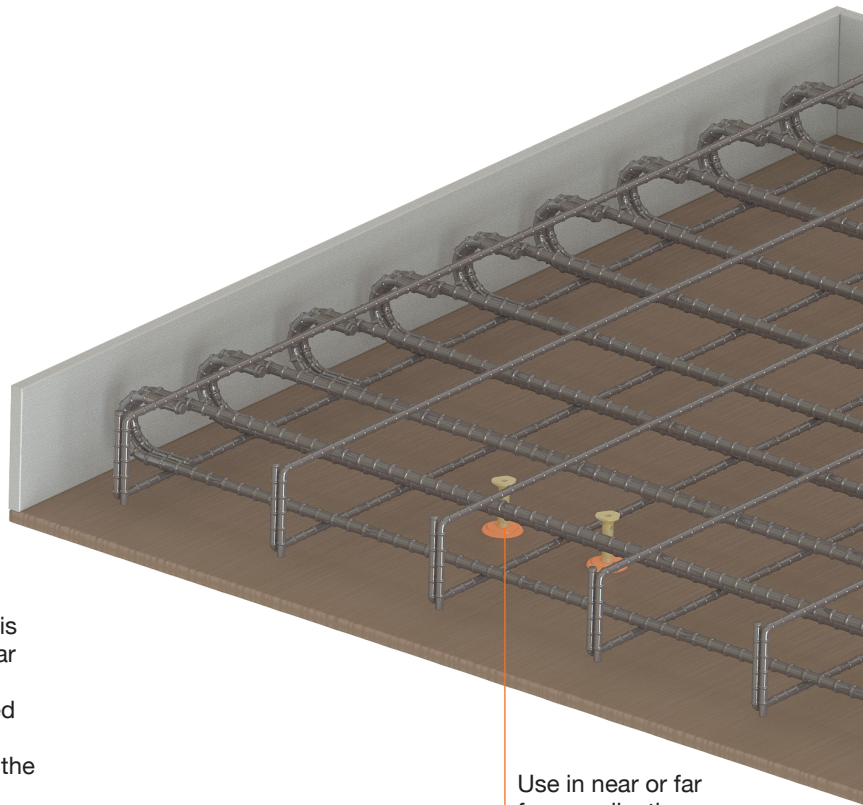

Use in near or far face applications with our range of accessories

Table 4D Modification factor for anchor, edge distance, ψ_g

	c_1 - distance from the centre of resistance of an anchor to the edge of the concrete in the direction which the load is applied, mm												
	30	35	40	50	60	85	100	200	300	400	500	≥ 600	
c_2 - minimum edge distance or half of anchor spacing perpendicular to c_1 , mm	30	0.90	0.87	0.85	0.82	0.80	0.77	0.76	0.73	0.72	0.72	0.71	0.71
	35	0.93	0.90	0.88	0.84	0.82	0.78	0.77	0.74	0.72	0.72	0.71	0.71
	40	0.97	0.93	0.90	0.86	0.83	0.79	0.78	0.74	0.73	0.72	0.72	0.71
	50	1.00	0.99	0.95	0.90	0.87	0.82	0.80	0.75	0.73	0.73	0.72	0.72
	60		1.00	1.00	0.94	0.90	0.84	0.82	0.76	0.74	0.73	0.72	0.72
	70			1.00	0.98	0.93	0.86	0.84	0.77	0.75	0.74	0.73	0.72
	100				1.00	1.00	0.94	0.90	0.80	0.77	0.75	0.74	0.73
	200						1.00	1.00	0.90	0.83	0.80	0.78	0.77
	300								1.00	0.90	0.85	0.82	0.80
	450									1.00	0.94	0.88	0.85
	600										1.00	0.94	0.90
	750											1.00	0.95
	1000												1.00

Diagram 4D Distance from the centre of resistance to the edge

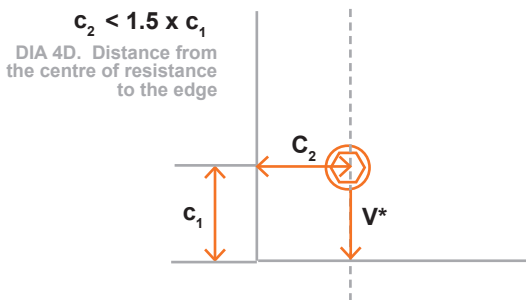

Table 4E Calculate the projected concrete failure area of anchor in shear when not limited by edge distance, $A_{v0} = 4.5c_1^2$

c_1	30	35	40	50	60	70	100	200	300	400	500	600
$A_{v0} (x10^4)$	0.4	0.6	0.7	1.1	1.6	2.2	4.5	18.0	40.5	72.0	112.5	162.0

Table 4F Calculate $1.5c_1$

c_1	30	35	40	50	60	70	100	200	300	400	500	600
$1.5c_1$	45	52.5	60	75	90	105	150	300	450	600	750	900

Computation 4H Calculate the project concrete failure area of anchor in shear

$$A_v = (c_{2a} + c_{2b}) * b_m, (c_{2a}, c_{2b}, b_m \leq 1.5c_1)$$

c_{2a}, c_{2b} = Edge distance or half of anchor spacing perpendicular to the loading direction (but less than or equal to $1.5c_1$).

b_m = Substrate Thickness (but less than or equal to $1.5c_1$)

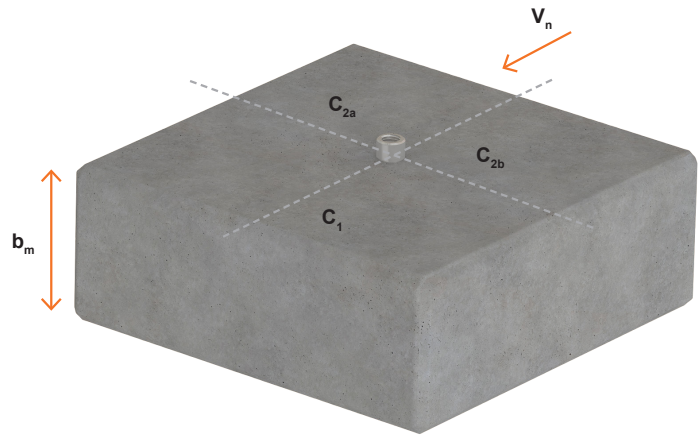

Checkpoint 4

Design Concrete Breakout Strength shear load towards edge of a single anchor, ϕV_{CB}

$$\phi V_{CB} = \phi V_B * \psi_{vcr} * \psi_{vc} * \psi_5 * \psi_{6A} * \psi_{6B} * A_v / A_{v0}$$

For when shear load direction is parallel to edge (i.e load angle = 180°) of a singular anchor, **MULTIPLY $\phi V_{CB} \times 2^*$**

*For anchors or anchor groups located at or near corners the shear strength shall be determined in each direction

Step 5. Verify Shear Strength of Steel ϕV_s (kN)

Table 5A Reduced characteristic ultimate anchor steel shear capacity, ϕV_{s1} (kN), $\phi = 0.65$

Product Code	TIM10X40G	TIM12X50G	TIM16X75G	TIM20X75G	TIM20X120G	TIM24X100G
ϕV_{s1} [kN]	10.1	12.7	19.9	41.1	41.1	64.1

Product Code	FE10045SS	FE12055SS	FE16070SS	FE20095SS
ϕV_{s1} [kN]	21.0	26.1	40.0	61.3

Table 5B Reduced characteristic ultimate bolt steel shear capacity, ϕV_{s2} (kN), $\phi = 0.80$

Zinc Bolt Size	M10		M12		M16		M20		M24	
ϕV_{s2} [kN]	G4.6	G8.8	G4.6	G8.8	G4.6	G8.8	G4.6	G8.8	G4.6	G8.8
	9.8	20.0	14.4	29.3	27.4	56.1	43.0	88.3	62.0	127.2

AISI 316 SS Bolt Size	M10	M12	M16	M20
ϕV_{s2} [kN]	16.8	24.7	47.4	74.5

Step 6. Verify Concrete Pry-Out Strength In Shear, ϕV_{cp} (kN), $\phi = 0.65$

Table 6A Co-efficient of pry out strength

h = length of insert (mm) plus 8mm for nail plate if used

h	<65mm	≥65mm
k_{cp}	1.0	2.0

Checkpoint 5

Concrete Pry-Out Strength in Shear

$$\phi V_{cp} = k_{cp} * \phi N_{urc}$$

Checkpoint 6

Design Reduced Ultimate Concrete Shear Capacity Perpendicular to an Edge, ϕV_{ur}

$$\phi V_{ur} = \text{MINIMUM OF } \phi V_{CB}, \phi V_{S1}, \phi V_{S2}, \phi V_{cp}$$

If not satisfied return to Step 1

Step 7. Combined Loading & Specification

Checkpoint 7

Check

$$N^*/\phi N_{ur} + V^*/\phi V_{ur} \leq 1.2,$$

If not satisfied return to Step 1

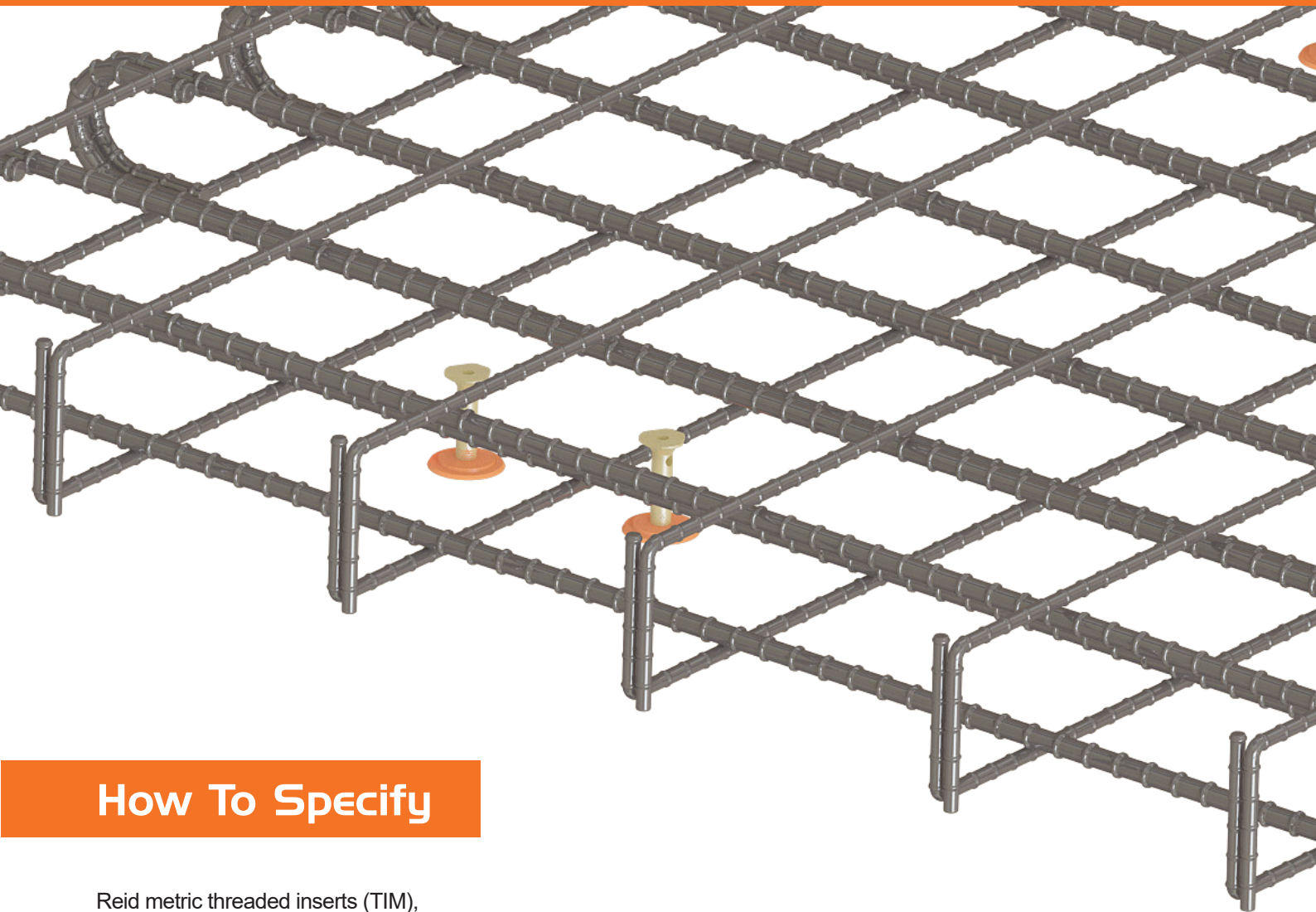

How To Specify

Reid metric threaded inserts (TIM),
(TIM size x length) (part number), (finish) with a (bolt grade) bolt.

Reid 316 stainless steel elephant foot™ metric threaded inserts
(FE size x length) (part number) with a (bolt grade) bolt.

Example

Reid Metric Threaded Insert 16mm x 75mm long.
TIM16X75G, Galvanised Finish With a Grade 4.6 Bolt.
To Be Installed In Accordance With Reid Technical Data Sheet.

Project	Sketch
Location	
Project ID	
Design by	
Date	
Checked	

Inputs

N* and V* are the per anchor load demand.
Check both external and internal anchors for suitability.

Tensile design action effect N^* kN

Shear design action effect V^* kN

Substrate thickness b_m mm

Concrete compressive strength f'_c MPa

STEP 1 SELECT ANCHOR TO BE EVALUATED

Table 1A: Find the interaction of N^* and V^* values

Anchor Type

Table 1A: Absolute minima, edge distance and half of anchor spacing

e_m

Check for compliance with absolute minima

Checkpoint 1:

Anchor size selected?

Comply with absolute minima?

STEP 2 VERIFY CONCRETE TENSILE CAPACITY

Table	Description	Symbol	Value	Unit
2A	Concrete tensile capacity	ΦN_{uc}		kN
2B-1	Cracked concrete reduction factor	Ψ_{ncr}		
2B-2	Concrete compressive strength effect	Ψ_{nc}		

Computation 2E: Edge distance and anchor spacing reduction factors.

Factor	Type	Table	Value
ΦX_1			
ΦX_2			
ΦX_1			
ΦX_2			

Checkpoint 2:

$\Phi N_{urc} = \Phi N_{uc} * \Psi_{nc} * \Psi_{ncr} * \Phi X_1 * \Phi X_2 * \Phi y_1 * \Phi y_2 =$ kN

STEP 3 VERIFY STEEL TENSILE CAPACITY

Table	Description	Symbol	Value	Unit
3A	Anchor steel capacity	ΦN_{us}		kN
3B	Bolt steel capacity	ΦN_{TF}		kN

Checkpoint 3:

$\Phi N_{ur} =$ minimum of ΦN_{urc} , ΦN_{us} and $\Phi N_{TF} =$ kN

$N^* / \Phi N_{ur} \leq 1.0?$ / = Tick

If not satisfied, return to Step 1. **Tensile Design Completed**

STEP 4 VERIFY CONCRETE SHEAR CAPACITY

Table	Description	Symbol	Value	Unit
4A	Concrete shear capacity	ΦV_b		kN
4B-1	Concrete crack failure	Ψ_{vcr}		
4B-2	Concrete compressive strength effect	Ψ_{vc}		
4C	Anchor group factor	Ψ_s		
4D	Edge distance factor	Ψ_{6A}		
	Edge distance factor (for the other edge)	Ψ_{6B}		
4E	Projected failure area when not limited by edge distance	A_{v0}		mm ²

Computation 4H: Projected concrete failure area of anchor A_v

Edge distance / Half of anchor spacing, mm	Original value, A	Table 4E, 1.5c ₁ = B	Calc value, min (A,B)
c_{2a}			
c_{2b}			
b_m			
$A_v = (c_{2a} + c_{2b}) * b_m$			

Checkpoint 4:

Calculate: $\Phi V_{CB} = \Phi V_b * \Psi_{vcr} * \Psi_{vc} * \Psi_s * \Psi_{6A} * \Psi_{6B} * A_v / A_{v0}$
= kN

STEP 5 VERIFY STEEL SHEAR STRENGTH

Table	Description	Symbol	Value	Unit
5A	Steel shear capacity	ΦV_{s1}		kN
5B	Bolt shear capacity	ΦV_{s2}		kN

STEP 6 VERIFY CONCRETE PRY-OUT STRENGTH IN SHEAR

Table 6A: Pry-out coefficient $k_{cp} =$

Checkpoint 5:

Calculate: $\Phi V_{cp} = k_{cp} * \Phi N_{urc} =$ kN

Checkpoint 6:

$\Phi V_{ur} =$ minimum of ΦV_{CB} , ΦV_{s1} , ΦV_{s2} and $\Phi V_{cp} =$ kN

$V^* / \Phi V_{ur} \leq 1.0?$ / = Tick

Shear Design Completed

STEP 7 COMBINED LOADING AND SPECIFICATION

Checkpoint 7:

$N^* / \Phi N_{ur} + V^* / \Phi V_{ur} \leq 1.2?$

+ = kN

If not satisfied, return to Step 1.

SPECIFY:

Additional notes / specification details

Product Compliance

Compliance statement

Reid™ Metric Threaded Inserts comply with the New Zealand Building Code clauses identified below.

Compliance details: NZBC

NZBC Clause	Criteria	Compliance Status
B1.3.1	'Buildings, building elements and sitework shall have a low probability of rupturing, becoming unstable, losing equilibrium, or collapsing during construction or alteration and throughout their lives.'	
B1.3.2	'Buildings, building elements and sitework shall have a low probability of causing loss of amenity through undue deformation, vibratory response, degradation, or other physical characteristics throughout their lives, or during construction or alteration when the building is in use.'	
B1.3.3 (a), (b), (d), (e), (f), (g), (h), (i), (q)	'Account shall be taken of all physical conditions likely to affect the stability of buildings, building elements and sitework, including: (a) Self weight, (b) Imposed gravity loads arising from use . . . (d) Earth pressure, (e) Water and other liquids, (f) Earthquake, (g) Snow, (h) Wind . . . (j) Impact . . . (q) Time dependent effects including creep and shrinkage.'	
B1.3.4	'Due allowance shall be made for: (a) The consequences of failure, (b) The intended use of the building, (c) Effects of uncertainties resulting from construction activities, or the sequence in which construction activities occur, (d) Variation in the properties of materials and the characteristics of the site, and (e) Accuracy limitations inherent in the methods used to predict the stability of buildings.'	
B2.3.1	'Building elements must, with only normal maintenance, continue to satisfy the performance requirements of this code for the lesser of the specified intended life of the building, if stated, or: (a) The life of the building, being not less than 50 years, if (i) Those building elements . . . Provide structural stability to the building, or (ii) Those building elements are difficult to access or replace, or (iii) Failure of those building elements to comply with the building code would go undetected during both normal use and maintenance of the building.'	
B2.3.2	B2.3.2 Individual building elements which are components of a building system and are difficult to access or replace must either: (a) All have the same durability, or (b) Be installed in a manner that permits the replacement of building elements of lesser durability without removing building elements that have greater durability and are not specifically designed for removal and replacement.	



Customer Service

Reid™ Australia

Tel: 1300 780 250

Email: sales@itwcsanz.com

Web: www.reid.com.au

Reid™ New Zealand

Tel: 0800 88 22 12

Email: sales@ramsetreid.co.nz

Web: www.reids.co.nz

Reid™ Construction Systems (RCS)

AUS: 1 Ramset Drive, Chirnside Park, Victoria, Australia, 3116

NZ: 23-29 Poland Road, Glenfield, Auckland 0632

Information in this document is correct at the time of printing. Readers should contact Reid™ or consult Reid™ detailed technical information to ensure product is suitable for intended use prior to purchase. ITW Australia Pty Ltd ABN 63 004 235 063 trading as Reid™ © copyright 2026. ™ Trademarks of Illinois Toolworks Inc used under license by Reid™

Important Disclaimer: Any engineering information or advice ("Information") provided by Reid™ in this document is issued in accordance with a prescribed standard, published performance data or design software. It is the responsibility of the user to obtain its own independent engineering (or other) advice to assess the suitability of the Information for its own requirements. To the extent permitted by law, Reid™ will not be liable to the recipient or any third party for any direct or indirect loss or liability arising out of, or in connection with, the Information. None of the products listed in this document are subject to a warning or ban under the Building Act 2004.

