

RCAD490

Dual Stud Articulating TV Mount

kanto
INSTALLER SERIES

NO ONLINE SALES

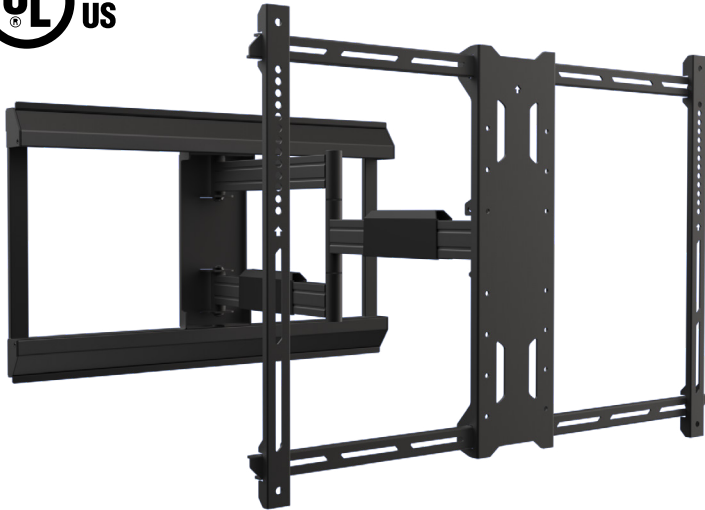

UP TO 150 LB



49"–100"



700 x 500



2.4" PROFILE
29.5" EXTENSION



+15° TO
–3° TILT



16" OR 24"
STUD SUPPORT



11" HORIZONTAL
OFFSET

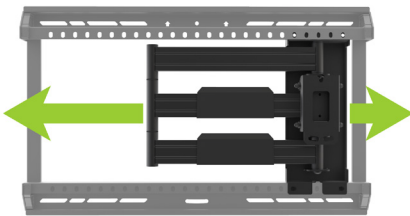

PERFECT PLACEMENT

With the ability to offset the articulating arm independently of the wall plate, you'll be able to position your clients' TV perfectly on the wall regardless of stud layout.

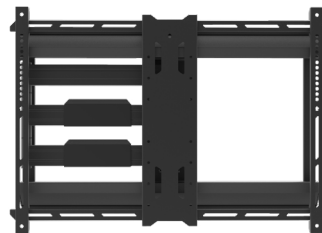

UNIVERSALLY COMPATIBLE

Boasting an impressive 150 lb weight capacity and support for VESA patterns up to 700x500, RCAD490 is suitable for nearly any TV on the market.



FULLY ADJUSTABLE

RCAD490 articulating TV mount can be tilted forward 15° or backward 3° and swivel up to 90° in either direction. Post-installation horizontal leveling lets you dial in your clients' TV perfectly.



MADE FOR PROFESSIONALS

The RCAD490 TV wall mount comes with sleek aluminum magnetic wall plate covers to hide any sign of installation, and installer-friendly snap on cable management clips with plenty of room for bulky wiring.

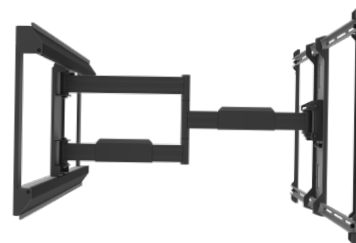

PLENTIFUL EXTENSION

Even with its low-profile design, RCAD490 TV wall mount can extend an impressive 29.5" from the wall, giving you plenty of room to work behind the TV and allow your customer to position their TV wherever they'd like.

Features and Specifications

- Fits most TVs from 49" to 100"
- Supports TVs up to 150 lb (68 kg)
- Accommodates VESA sizes from 100x100 to 700x500
- 11" (27.9 cm) of adjustable horizontal offset from center position
- Accessible tilt mechanism provides a -3 to +15° tilt angle
- 90° of swivel in either direction, depending on screen size
- Sits 2.4" (6 cm) and extends up to 29.5" (74.9 cm) from the wall
- Installer-friendly, snap on cable management clips
- Adjustable horizontal leveling
- 28.9" (73.3 cm) wall plate accommodates up to 24" stud spacing
- Solid steel construction with durable powder coated finish
- Includes manual and all mounting hardware for wood stud and concrete installation
- UL listed
- Ten year manufacturer's warranty
- Shipping box weight: 38.3 lb (17.4 kg)
- Shipping Box Dimensions: 31.3" x 19.2" x 4.6" (79.5 x 48.7 x 11.6 cm)
- Product Weight: 34.1 lb (15.5 kg)
- UPC: 800152721194

DIMENSIONS

