

NUT

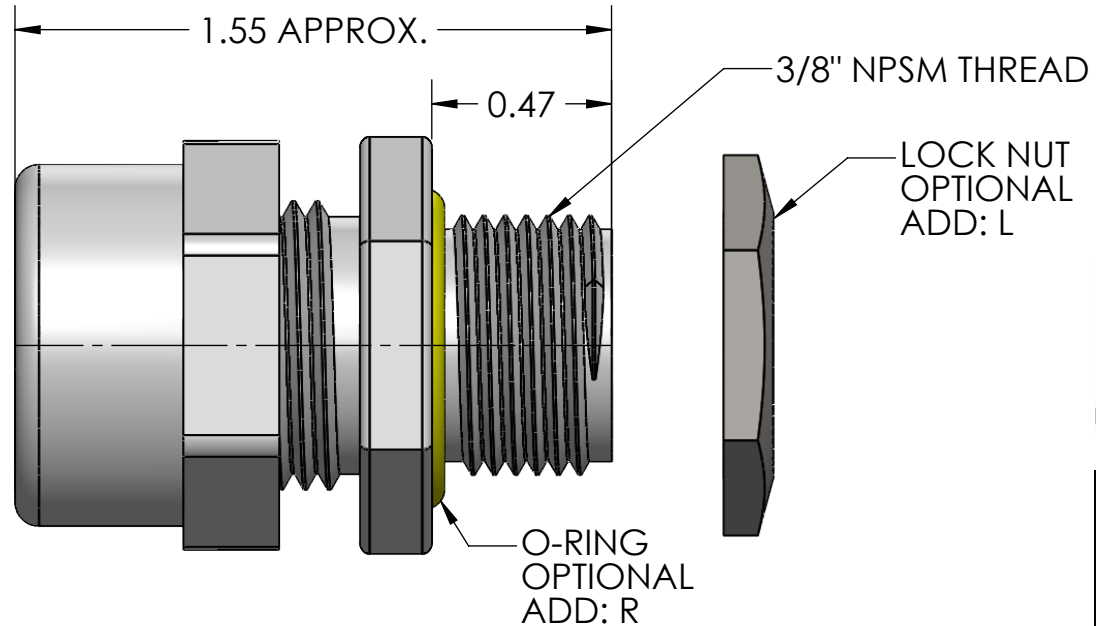

ITEM NO.	PART NUMBER	DESCRIPTION	MATERIAL	QTY.
1	RSP-000-B	BODY	NYLON 6/6	1
2	SRB-003 - SRB-007	BUSHING	NEOPRENE	1
3	RSP-000-WB	WASHER	NYLON 6/6	1
4	RSP-000-N	NUT	NYLON 6/6	1
5	SOR-38	O-RING	ADD: R, BUNA-N	1
6	LN-38	LOCKNUT	ADD: L, C.R.S. ZINC PLATED	1

PART NUMBER	SEALING RANGE	BODY BORE
RSP-003	.125 - .188	.450
RSP-004	.188 - .250	.450
RSP-005	.250 - .312	.450
RSP-006	.312 - .375	.450
RSP-007	.375 - .438	.450

REV.	DATE	CHANGE	UNLESS OTHERWISE SPECIFIED:	NAME	DATE	REMKE REMKE INDUSTRIES 310 CHADDICK DR, WHEELING, IL. 60090	
A	5/30/13	DRAWING RELEASED	DIMENSIONS ARE IN INCHES TOLERANCES: FRACTIONAL $\pm 1/64$ ANGULAR: MACH $\pm 1^\circ$ BEND $\pm 1^\circ$ ONE PLACE DECIMAL $\pm .015$ TWO PLACE DECIMAL $\pm .010$ THREE PLACE DECIMAL $\pm .005$	DRAWN	JCN	5/13	TITLE:
			INTERPRET GEOMETRIC TOLERANCING PER:	CHECKED			RSP-000 SERIES
			MATERIAL	ENG APPR.			SIZE
			PLASTIC	MFG APPR.			DWG. NO.
			FINISH	Q.A.			A RSP-000 ASSEMBLY
			DO NOT SCALE DRAWING	PROPRIETARY AND CONFIDENTIAL THE INFORMATION CONTAINED IN THIS DRAWING IS THE SOLE PROPERTY OF REMKE INDUSTRIES. ANY REPRODUCTION IN PART OR AS A WHOLE WITHOUT THE WRITTEN PERMISSION OF REMKE INDUSTRIES IS PROHIBITED.			SCALE: 2:1
							SHEET 1 OF 1