

Ø 3.92
BODY

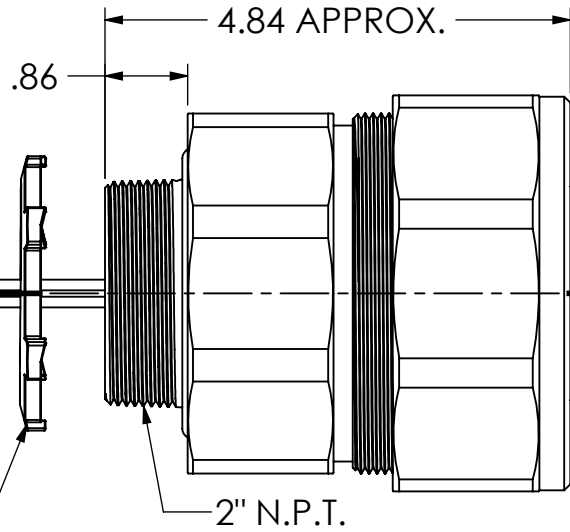

LOCK NUT
OPTIONAL
ADD: L

Ø 4.34
NUT

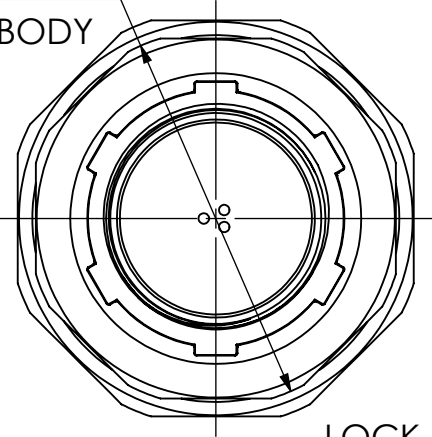
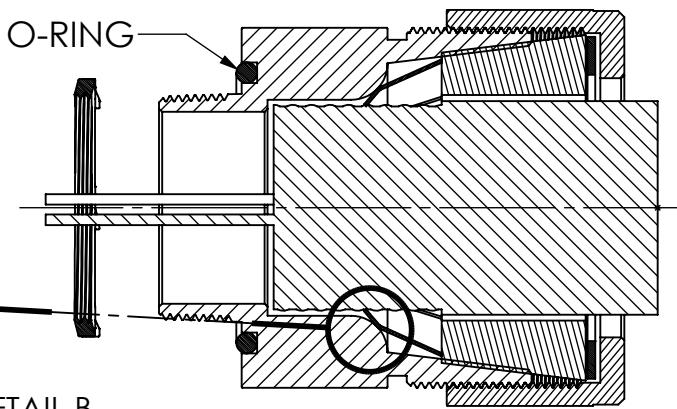
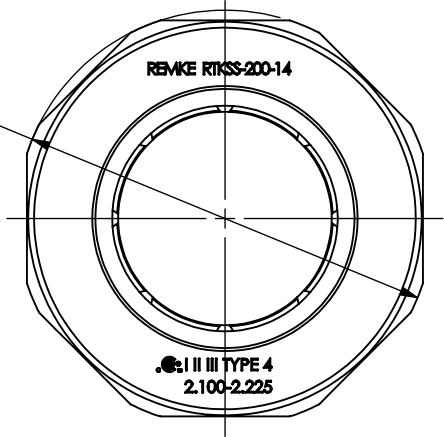

DETAIL B
SCALE 2 : 1

SECTION A-A

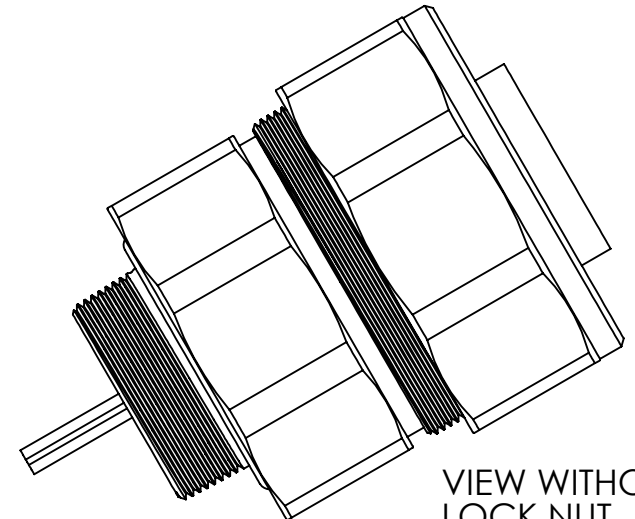

VIEW WITHOUT
LOCK NUT



REV.	DATE	CHANGE
A	7/30/14	DRAWING RELEASED

UNLESS OTHERWISE SPECIFIED:
 DIMENSIONS ARE IN INCHES
 TOLERANCES:
 FRACTIONAL ± 1/64
 ANGULAR: MACH ± 1° BEND ± 1°
 ONE PLACE DECIMAL ± .015
 TWO PLACE DECIMAL ± .010
 THREE PLACE DECIMAL ± .005
 INTERPRET GEOMETRIC TOLERANCING PER:
 MATERIAL **STAINLESS**
 FINISH
 DO NOT SCALE DRAWING

NAME	DATE
DRAWN JCN	7/14
CHECKED	
ENG APPR.	
MFG APPR.	
Q.A.	

PROPRIETARY AND CONFIDENTIAL
 THE INFORMATION CONTAINED IN THIS DRAWING IS THE SOLE PROPERTY OF REMKE INDUSTRIES. ANY REPRODUCTION IN PART OR AS A WHOLE WITHOUT THE WRITTEN PERMISSION OF REMKE INDUSTRIES IS PROHIBITED.

REMKE
 REMKE INDUSTRIES
 310 CHADDICK DR, WHEELING, IL. 60090

TITLE:

SIZE **A** DWG. NO. **RTKSS-200-14**

SCALE: 1:2 SHEET 1 OF 1