

- NOTES:  
 1.) PART A IS PLATED ELECTROLESS NICKEL .0001 MIN-.0003 MAX.  
 2.) PART UP IS UNPLATED  
 3.) BREAK ALL SHARP CORNERS  
 4.) REF. BAR-04 (1-1/4" HEX SOLID)

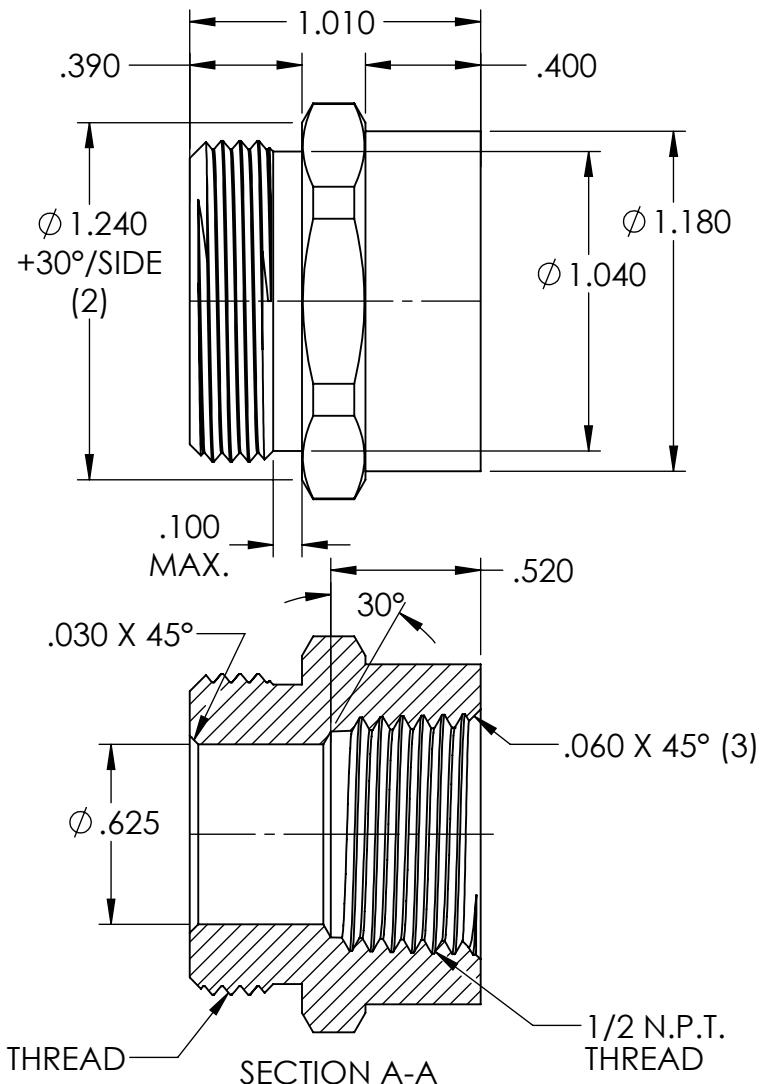

REV.	DATE	CHANGE	UNLESS OTHERWISE SPECIFIED:	NAME	DATE	<b>REMKE</b> <b>REMKE INDUSTRIES</b> 310 CHADDICK DR, WHEELING, IL. 60090	
A	5/21/02	TOOLING AND PRODUCTION RELEASED C.V.	DIMENSIONS ARE IN INCHES TOLERANCES: FRACTIONAL $\pm 1/64$ ANGULAR: MACH $\pm 1^\circ$ BEND $\pm 1^\circ$ ONE PLACE DECIMAL $\pm .015$ TWO PLACE DECIMAL $\pm .010$ THREE PLACE DECIMAL $\pm .005$	DRAWN JCN	7/15	TITLE: <b>ADAPTER</b>	
B	7/30/15	REDRAWN	INTERPRET GEOMETRIC TOLERANCING PER:	CHECKED		SIZE DWG. NO. <b>A</b> <b>RAPG-21M50F-A</b>	
			MATERIAL <b>ALUMINUM</b>	ENG APPR.		SCALE: 1.5:1	
			FINISH <b>NICKEL PLATED</b>	MFG APPR.		SHEET 1 OF 1	
			DO NOT SCALE DRAWING	Q.A.		PROPRIETARY AND CONFIDENTIAL THE INFORMATION CONTAINED IN THIS DRAWING IS THE SOLE PROPERTY OF REMKE INDUSTRIES. ANY REPRODUCTION IN PART OR AS A WHOLE WITHOUT THE WRITTEN PERMISSION OF REMKE INDUSTRIES IS PROHIBITED.	

5

↑

4

3

2

1