

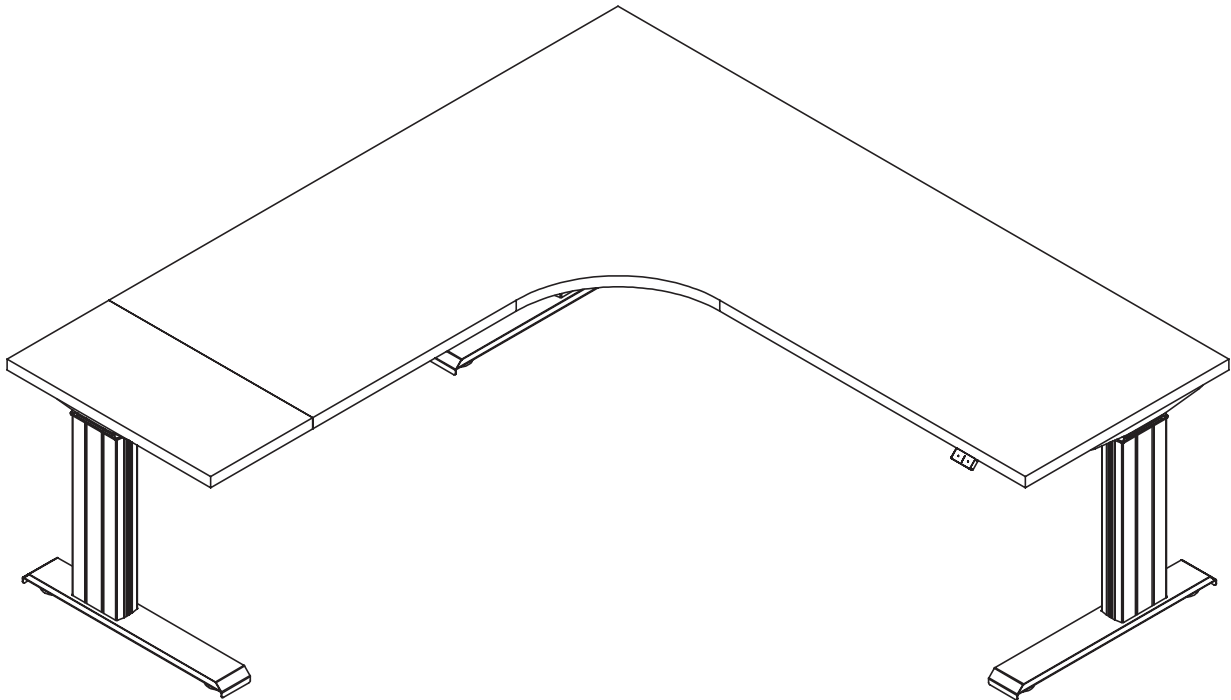

NewHeights™ Series 4 Elegante XT 3-Leg Workstation Workstation Assembly Instructions

Warranty: raproducts.com/warranty



Failure to comply with or observe all assembly, safety, and operation instructions and warnings regarding use of this product may result in serious property damage or bodily injury. Read all instructions before beginning.

Make sure no obstacles are in the desk's path and all cords are of appropriate length for the desk. Always maintain a 1" clearance around the table to prevent pinching.

Never assemble (or disassemble) the table or components with the table plugged into a power outlet. This product is for use on a nominal 120-volt circuit and has a grounding plug. Make sure that the product is connected to an outlet having the same configuration as the plug. No adapter should be used with this product.

Duty Cycle: 2 minutes ON / 18 minutes OFF

Workstation can continuously operate for a maximum duration of two minutes. After two minutes of non-stop operation, the workstation will automatically stop and require eighteen minutes of cool down.

READ ALL INSTRUCTIONS BEFORE USING THIS PRODUCT.



**USE THIS PRODUCT ONLY AS INSTRUCTED.
FAILURE TO COMPLY WITH ALL INSTRUCTIONS AND WARNINGS
MAY RESULT IN SERIOUS PROPERTY DAMAGE OR BODILY INJURY.**

Basic Safety Instructions

- 1. Intended Use.** This Product is exclusively designed for use as indoor office furniture in compliance with all instructions and safety warnings in the user manual. Any different use, or use extending beyond the intended use, may result in property damage or bodily injury and is prohibited. This Product should not be used, operated or maintained with additional components not authorized by K&A Manufacturing, Inc.

BY USING THIS PRODUCT OR ANY FEATURE OF THIS PRODUCT, YOU AGREE TO COMPLY WITH ALL PRODUCT TERMS AND POLICIES, INCLUDING WITHOUT LIMITATION ANY SAFETY WARNINGS AND INSTRUCTIONS, PROVIDED BY K&A MANUFACTURING, INC. AND ITS AFFILIATES. K&A MANUFACTURING, INC. SHALL ASSUME NO LIABILITY FOR ANY DAMAGE OR INJURY CAUSED BY USE OF THE PRODUCT A) IN VIOLATION OF ANY SAFETY WARNINGS OR INSTRUCTIONS; B) NOT AUTHORIZED BY K&A MANUFACTURING, INC.; OR C) BY EVENTS BEYOND K&A MANUFACTURING, INC.'S CONTROL.



**DO NOT SIT, STAND OR CRAWL ON OR UNDER THE PRODUCT.
MAKE SURE NO OBSTACLES ARE IN THE PRODUCT'S PATH.
MAKE SURE ALL CORDS ARE LONG ENOUGH TO ACCOMMODATE ANY CHANGE IN HEIGHT.
DO NOT USE ATTACHMENTS NOT RECOMMENDED BY THE MANUFACTURER.**

- 2. Electrical Height Adjustment.** The height of this Product may be adjusted electronically. Contact with electrical voltage may cause serious injury and death. Only use the Product in compliance with these instructions. This Product should not be used in environments with high levels of humidity or moisture.

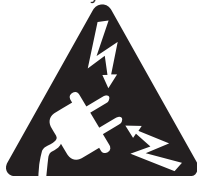

**KEEP CORDS AND ELECTRICAL COMPONENTS AWAY FROM HEAT AND LIQUIDS.
DO NOT OPEN ANY OF THE COMPONENTS: CONTROL BOX OR KEYPAD.
DO NOT USE WITH A DAMAGED PLUG OR CORD.
DO NOT INSERT ANYTHING INTO ANY SEAM OR OPENING.**

- 3. Setup and Use.** This Product should only be used and operated in good condition. When in use, no one should sit, stand or crawl on or under the Product. There is a danger of crushing, shearing, injury or damage. Keep the entire range of motion of the Product clear of all obstacles. Devices and object on the Product can tip over, fall or be crushed by the Product.



**KEEP HANDS AND FINGERS CLEAR.
KEEP ALL OBSTACLES CLEAR OF THE PRODUCT'S PATH.**

- 4. Users.** This Product is not intended for use with children, individuals with restricted physical, sensory or mental capabilities, or individuals who lack experience or knowledge, unless they are supervised by a person who is responsible for their safety or they have received instructions from a person who is responsible for their safety concerning how the Product must be used. Children should be closely supervised to ensure that they do not play with the Product and its height adjustment mechanism to avoid risk of physical injury or electric shock.



KEEP CHILDREN AWAY FROM THE PRODUCT, ITS CONTROL UNITS, AND KEYPADS.

Your workstation will have either two left legs (**Q**) and one right leg (**R**) or two right legs and one left leg. The drawing below shows how to distinguish the left leg from the right leg.

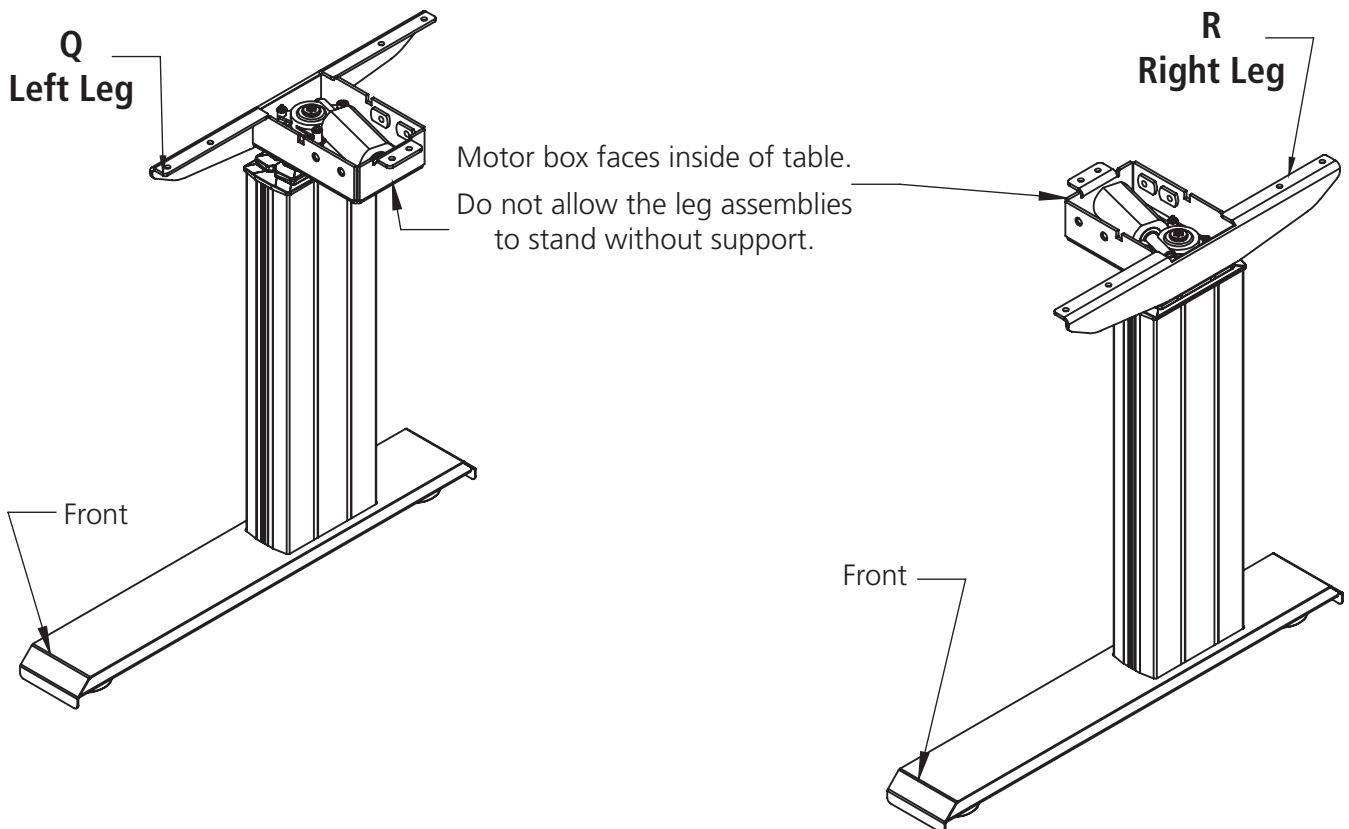
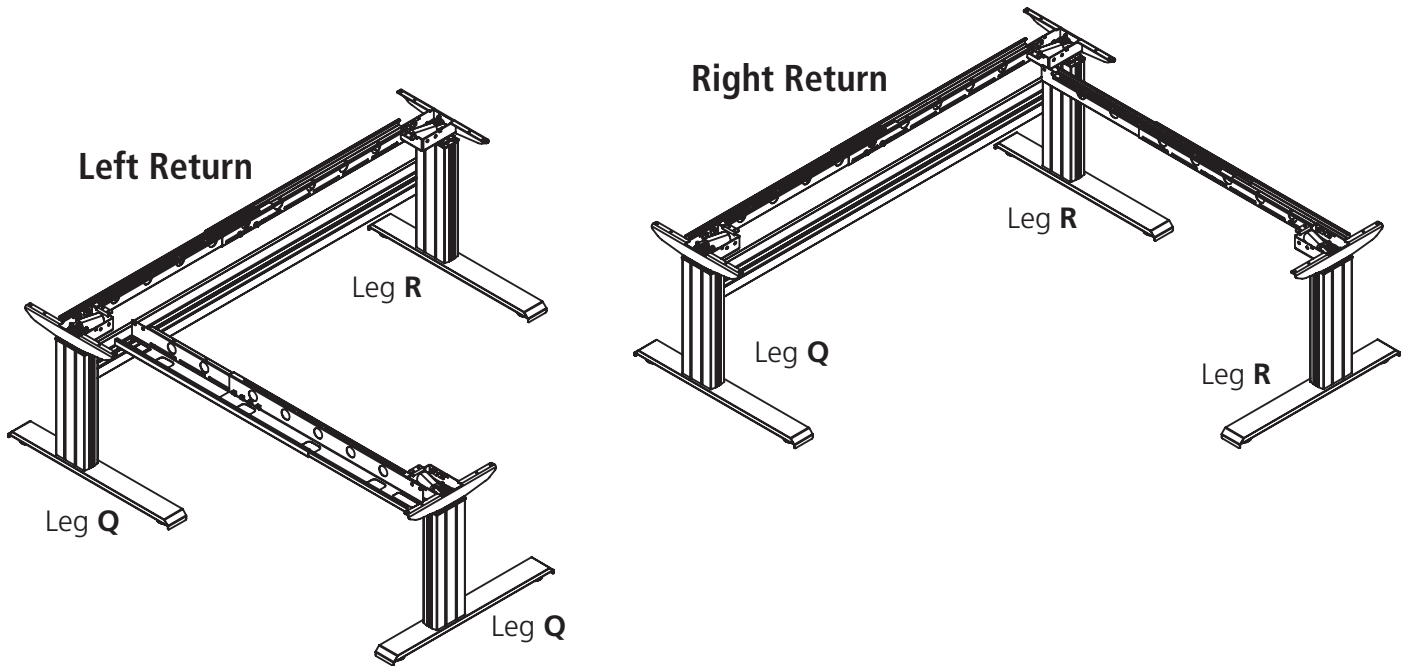

Tools Required for Assembly

- A. Power Driver with Adjustable Torque
- B. #2 Phillips Head Driver Bit
- C. #2 Square Head Drive Bit
- D. Level

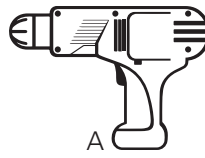

Hardware and Tools Included for Assembly (may have extra)

- E. 10 x 5/8" Round Washer Head Wood Screw x41
- F. 5/16"x 18-3/8" Button Socket Cap Screw x6
- G. 1/4 Blk Flat Washer x4
- H. 1/4-20 x 1/2 Blk Ph Hd Machine Screw x4
- I. Cable Clamp 3/16 Black x4
- J. 8 x 3/4" Pan Head Wood Screw x4
- K. Joiner Plate (Optional)

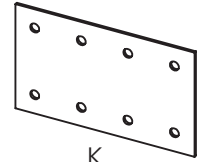
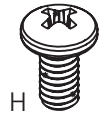
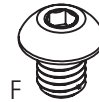

Elegante Parts

- L. Wire Management (size varies) x2
- M1. Two Button Up/Down Switch x1
- M2. Four Button Programmable Up/Down Switch x1
Optional - *If you have a programmable switch, please refer to the installation instructions included with the switch*
- N. Control Box for Three Motors x1
- O. Power Cord x1
- P. Power Strip x1
- Q. XT Left Leg x1 or 2
- R. XT Right Leg x1 or 2

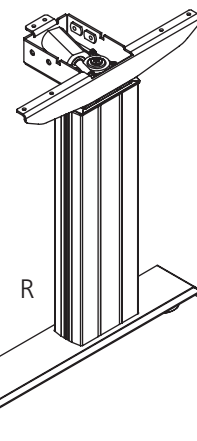
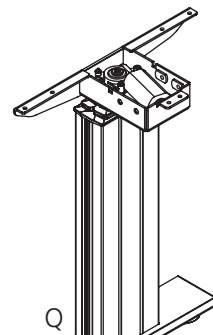
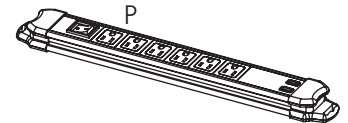
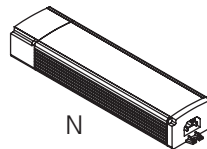
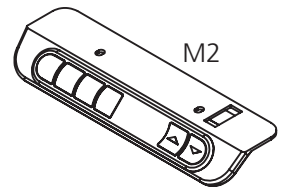
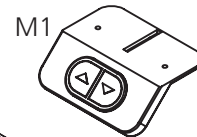
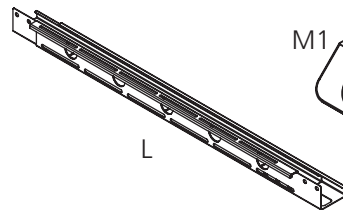

Step 1

- Lay the worksurface on a protected surface with the pilot holes facing up. If your worksurface has a seam, lay the joiner plate centered on the seam about 3" from the front.
- Attach worksurface with eight wood screws.
- Pilot holes are not provided, screws are self drilling.
- Set the legs on the worksurface, align the legs over the pilot holes.
- Attach the legs onto the worksurface with six wood screws. **Do not tighten.**

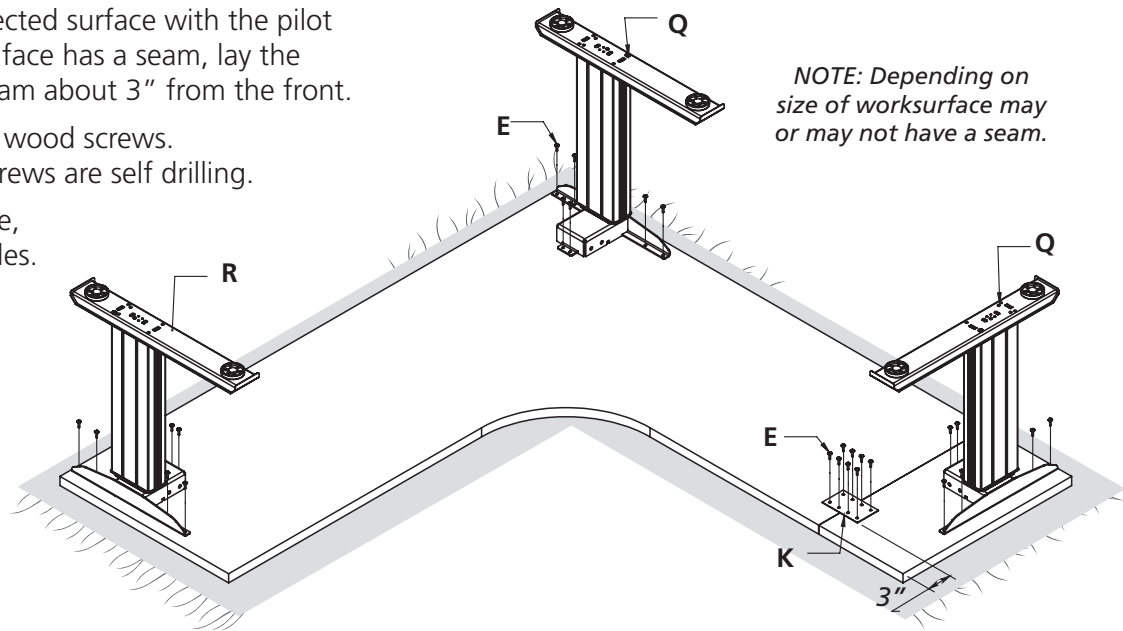
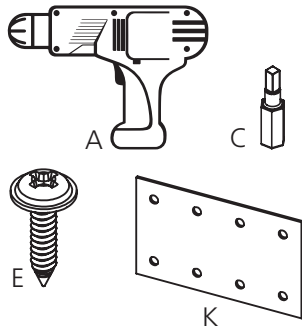

NOTE: Depending on size of worksurface may or may not have a seam.

Step 2

- Your workstation may have two different size wire management. Determine the correct location of the wire management channels according to the size of the worksurface.
- Slide apart the wire management and attach with four machine screws. **Do not tighten.**
- Install wood screws through the wire management and into the worksurface. Pilot holes are not provided, the screws are self drilling. **Do not tighten.**

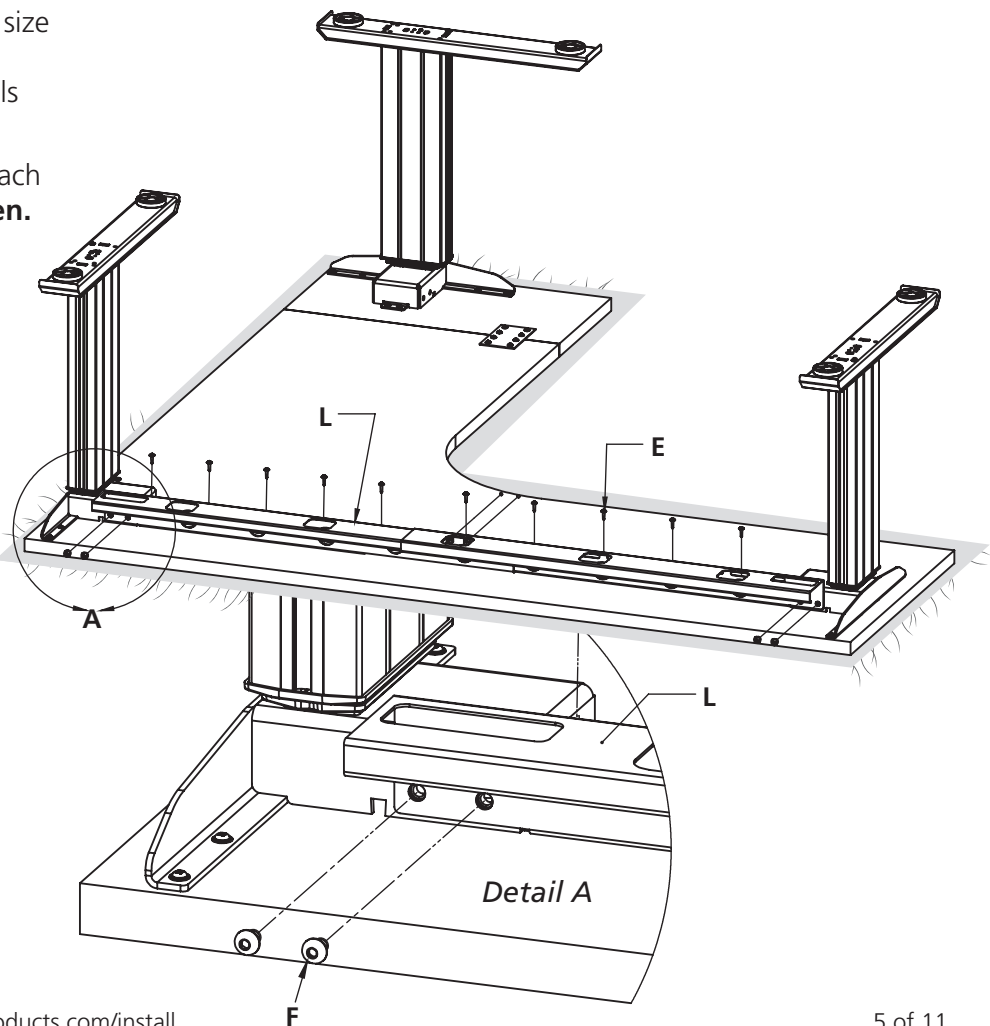
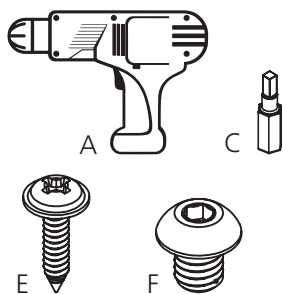

Step 3

- Attach the other wire management (**L**) to leg (**Q**) same way as the previous step.
- Insert machine screws and washers through the slots of both wire management and into any two cage nuts. **Do not tighten.**

Note: If your table comes with cross supports for added stability, please refer to those instructions for the next step.

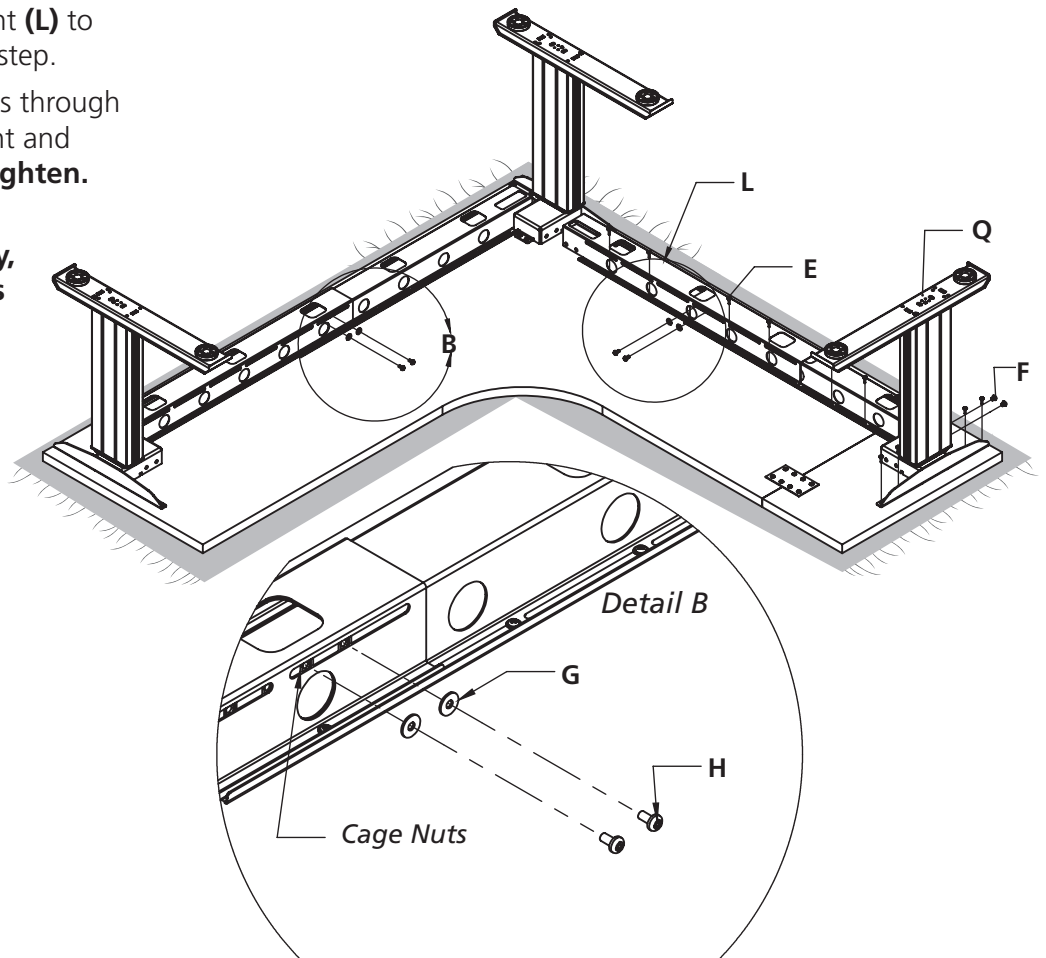
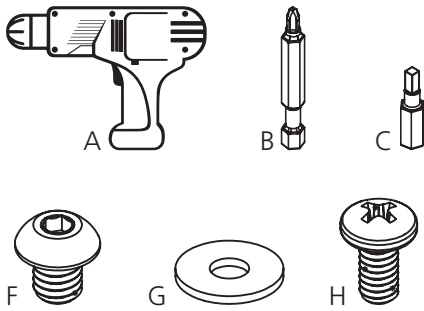

Step 4

- If your table comes with cross supports for added stability, please **refer to those instructions for this step.**
- If your table does not come with cross supports, continue to Step 5.

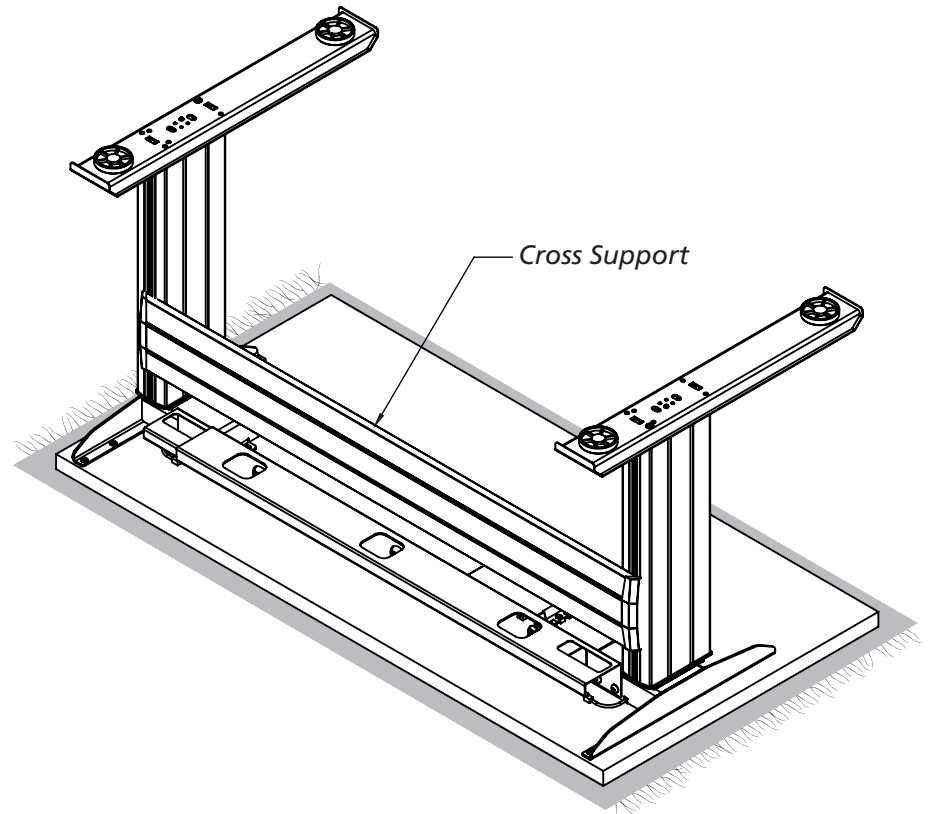

Step 5

- Fully tighten all screws and bolts.
- Install the switch, cable clamps, power strip, and control box. Pilot holes are provided only for the control box and switch.

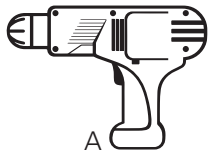

A



B



C



E



I



J

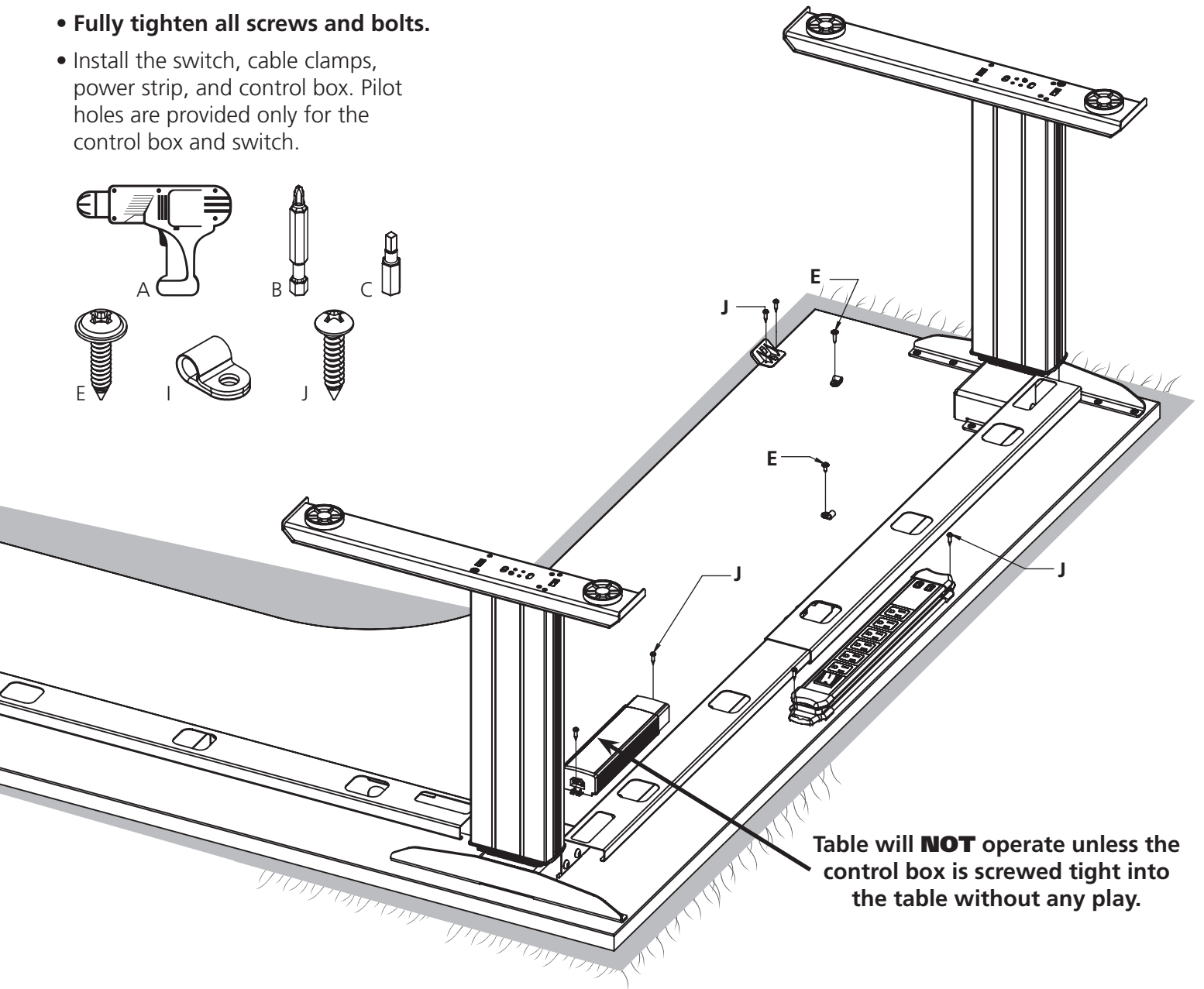
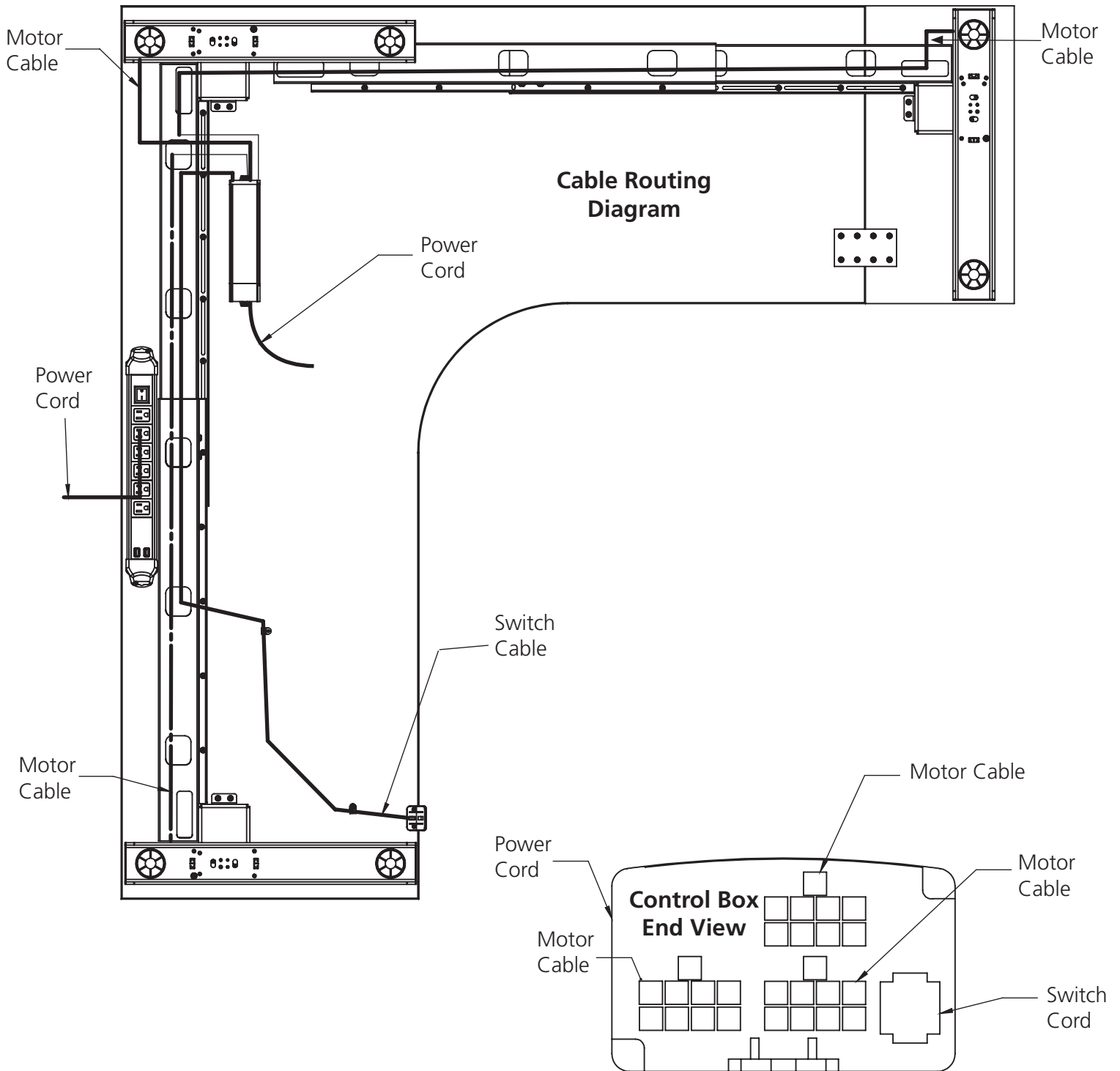

Table will **NOT** operate unless the control box is screwed tight into the table without any play.

Step 6

- Run all cables as shown on the diagram.



Caution:



For the safety of the user and the workstation; the control box contains an internal sensor that is sensitive to movement, vibration, and collision. For faultless operation, ensure all cables, electronics, and accessories are cable managed and secured. Excessive load or weight must be distributed evenly. Failure to follow these guidelines may cause intermittent functionality.

Standard Switch Save for Reference

Start Up Procedure:



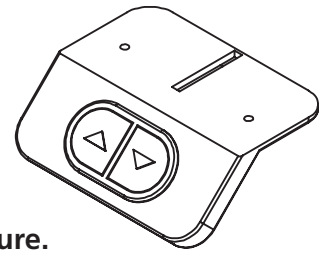









- Plug the power cord into a standard 110V receptacle. A power surge protector is recommended.
 - Press the down arrow until the worksurface reaches its lowest position.
 - The workstation is ready for use.
 - **If the table is not functioning normally or has lost power, perform the reset procedure.**
-













Reset Procedure:

- Unplug the unit from the wall for 10 seconds.
 - Clear all obstructions from the travel path of the desk.
 - Plug the unit back in the wall.
 - Press and hold the down arrow key until the table reaches its lowest position.
-

Add Container Stops:

- Move the table  to the upper or lower desired height.
 - Rapidly press  4 times. You will hear a musical tone. 
 - Rapidly press  2 times. A musical tone plays two times.  
 - To **add** the **upper** container stop press  A musical tone plays two times.  
 - To **add** the **lower** container stop press  A musical tone plays two times.  
-

Remove Container Stops:

- Move the table  to the upper or lower **preset** height.
 - Rapidly press  4 times. You will hear a musical tone. 
 - Rapidly press  2 times. A musical tone plays two times.  
 - To **delete** the **upper** container stop press  You will hear a musical tone. 
 - To **delete** the **lower** container stop press  You will hear a musical tone. 
-

Troubleshooting:

If you are having any problems with the operation, contact RightAngle Products at **800.298.4351** or **orders@raproducts.com**

Optional Programmable Switch (full instructions packaged with switch)

Start Up Procedure:

- Plug the power cord into a standard 110V receptacle. A power surge protector is recommended.
- Press the down arrow until the worksurface reaches its lowest position.
- The workstation is ready for use.
- **If the table is not functioning normally, or has lost power, perform the reset procedure.**

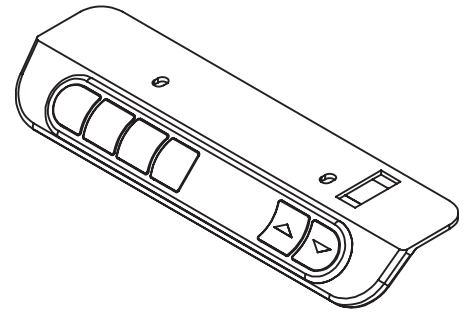

Reset Procedure:

- Unplug the unit from the wall for 10 seconds.
- Clear all obstructions from the travel path of the desk.
- Plug the unit back in the wall.
- Press and hold the down arrow key until the table reaches its lowest position

See Packaged Instructions for Programmable Options

Mechanical Reset Mode

If the table is unresponsive, uneven, or not functioning properly, perform a manual reset.









User settings are not reset in this process.

There are three methods to reset a workstation:

Reset Method A















1. Clear all obstructions from the travel path of the workstation
2. Disconnect the power to the control box for 30 seconds.
3. Reconnect the power
4. Press and hold the  until the workstation has reached its lowest possible position.

Reset Method B (4 button programmable switch required)

1. Clear all obstructions from the travel path of the workstation
2. Quickly press  +  +  +  to enter the menu mode.
3. P01 is displayed and you will hear a musical tone 
4. Press the   to navigate the menu.
5. Navigate to the P09 display
6. Press the  button to enter or accept
7. Press and hold the  until the workstation has reached its lowest possible position.

The workstation is now ready to operate

Reset Method C - 2 Button Switch

1. Clear all obstructions from the travel path of the workstation
2. Quickly press  +  +  +  to enter the menu mode.
3. You will hear a musical tone. 
4. Press  +  +  + 
5. You will reach the limit adjustment menu and hear four musical tones.    
6. Press and hold the  until the workstation has reached its lowest possible position.

The reference is re-calibrated, the table should be leveled and the height indication should be correct.