

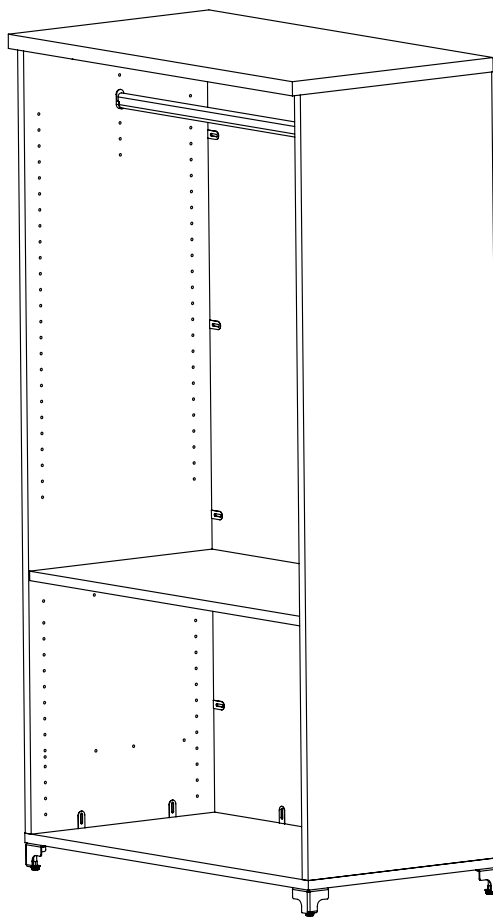

Tevita Casegoods Coat Rod Assembly Instructions



Warranty: raproducts.com/resources/warranty

Tools Required for Assembly

- A. Power Driver with Adjustable Torque
- B. #2 Phillips Head Driver Bit



Hardware Included for Assembly *(may have extra)*

- C. Bracket Screw x2



Parts

- D. Bracket x2
- E. Coat Rod x1

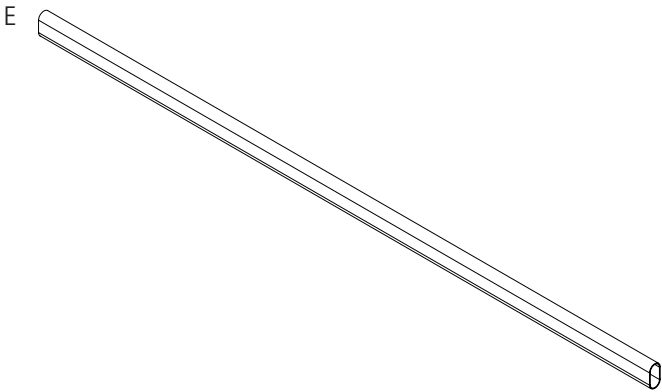
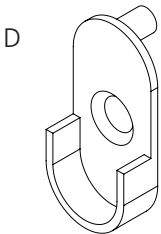

Step 1

- Once the vertical storage unit is fully assembled, identify your the desired height for the coat rod.
- Then, insert one bracket (D) into that position.
- Repeat with the second bracket (D) on the opposite side of the unit.

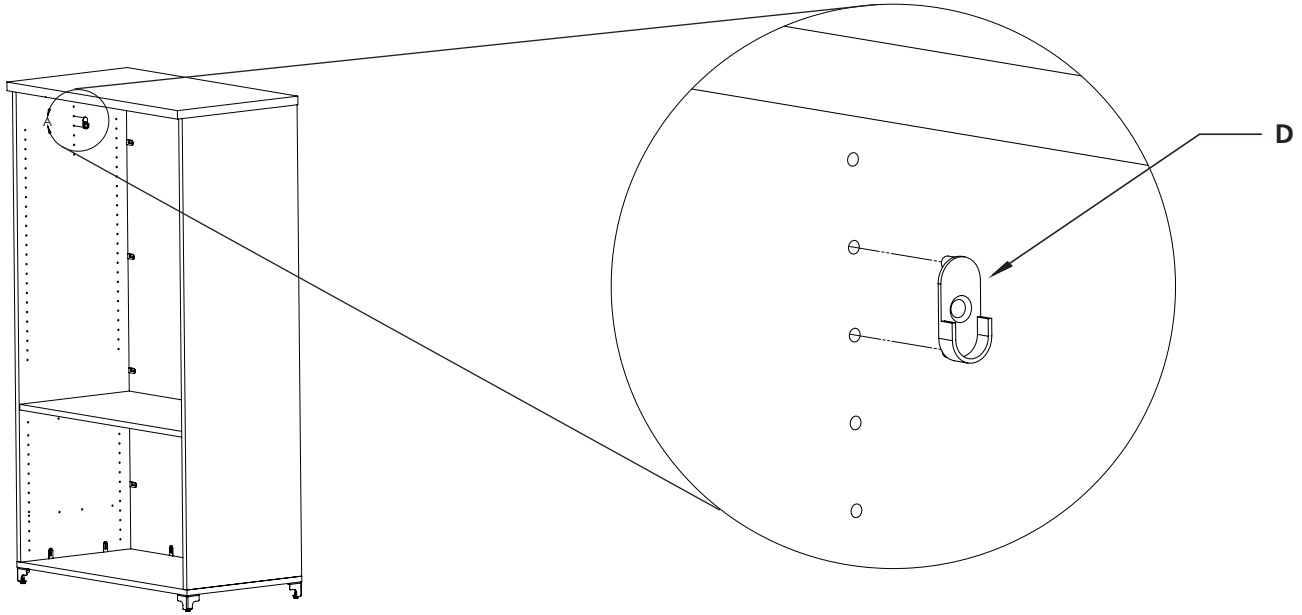

Step 2

- Secure each bracket (D) with a bracket screw (C).

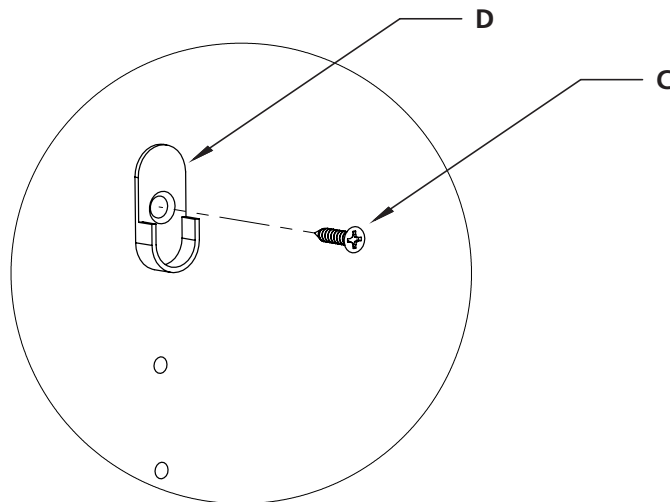
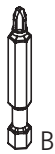
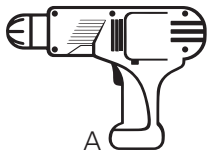

Step 3

- Slide the coat rod (E) onto the two brackets.

