

MILE HIGH FOAM®

CLOSED CELL POLYETHYLENE

TECHNICAL DATA SHEET

1. Product Name: **MILE HIGH FOAM®**
2. Exclusively Sold By: **Backer Rod Mfg. Inc.**
4244 N Broadway
Denver, CO 80216
Phone: 800-595-2950
Fax: 303-308-0393
Website: www.backerrod.com
3. Product Description:
Per ASTM C 1330 type C **Mile High Foam®** is a resilient, polyethylene backer rod used as a backing material for cold applied elastomeric caulking sealants. Mile High Foam® controls the depth of the sealant installation and ensures cross – sectional hour-glass configuration. No bond breaker is required.

Specific Uses:

- Expansion joints
- Highway joints
- Glazing
- Log home chinking
- Parking Decks
- Curtain walls
- Coping joints
- Isolation joints
- Temporary joint seal

4. Composition and Material:

Mile High Foam® is a round, black, resilient, extruded closed cell polyethylene backer rod with a water resistant outer skin. It is compatible with most known cold applied sealants such as urethane, silicone, acrylic, butyl, polysulfide, latex, and log chinking sealants.

5. Installation:

Joint openings must be free of all contaminants, loose materials, dry and free of frost. Select correct rod size for joint width. With a blunt instrument or roller, seat rod to depth recommended by sealant manufacturer.

6. Compatibility:

Mile High Foam® is chemically inert and will resist gasoline, oil, and most solvents. Product will not stain or adhere to sealants.

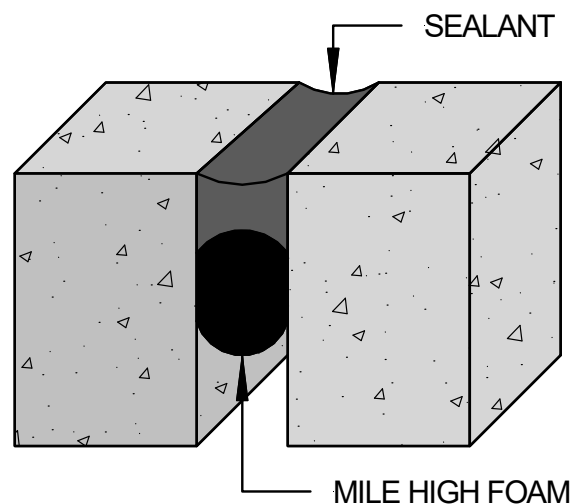

Backer Rod Mfg. Inc.

7. Physical Properties:

Physical Properties		
Property	Value	ASTM Test Method
Density (Normal)	1.25 - 2 lb/ft ³	D 1622
Out-gassing	> 1	C 1253
Compression Recovery	>90	D 5249
Tensile Strength PSI	39 - 50 psi	D 1623
Temperature Range	-90° F to 210°F	D 5249
Water Absorption	0.002 g/cm ³	C 1016 - Proc. B



8. Packaging Information

Packaging Information						
Linear Feet Per Unit/ (metric)				Weight & Measurements		
Diameter	Mini Box	Standard Box	Super Box	Mini Carton	18-1/4" x 18-1/4" x 15"	7 lbs ea.
1/4" (6mm)	3200 (975m)	6400 (1951m)		Standard Carton	18-1/4" x 18-1/4" x 30-1/2"	10 lbs ea.
3/8" (10mm)	1800 (548m)	3600 (1097m)				
1/2" (13mm)	1250 (381m)	2500 (762m)				
5/8" (16mm)	775 (236m)	1550 (472m)				
3/4" (19mm)	550 (167m)	1100 (335m)				
7/8" (22mm)		850 (257m)				
1" (25mm)		550 (168m)		Super Carton	18-1/4" x 18-1/4" x 74-1/4"	14 lbs ea.
1-1/4" (32mm)		400 (122m)		Mini Carton		• 1 spool per carton
1-1/2" (38mm)			420 (128m)	Standard Carton		• 1/4" through 3/4" 2 spools per carton • 7/8" through 1-1/4" 1 spool per carton
2" (51mm)			252 (77m)			
2-1/2" (63mm)			162 (49m)			
3" (76mm)			102 (31m)	Super Carton		• 1-1/2" through 4" manufactured in 6' lengths
4" (102mm)			54 (16m)			

9. Limitations

Do not use with hot applied sealants. Do not puncture, over compress or stretch **MILE HIGH FOAM®** during installation.

10. Availability and Cost

MILE HIGH FOAM® is marketed nationally and internationally by select authorized distributors. For name, address and telephone number of your nearest distributor please contact us at: 800-595-2950 or sales@backerrod.com

11. Warranty

Unless otherwise agreed to in writing, **MILE HIGH FOAM®** is sold without warranty, express or implied. Buyer must make their own determination as to the suitability of the product and application. Sizes and lengths of products shown are at time of packaging and will vary with climate conditions after manufacture.

12. Technical Services

Please contact Backer Rod Mfg. Inc. for technical guidance, special project engineering designs and drawings.



Backer Rod Mfg. Inc.