

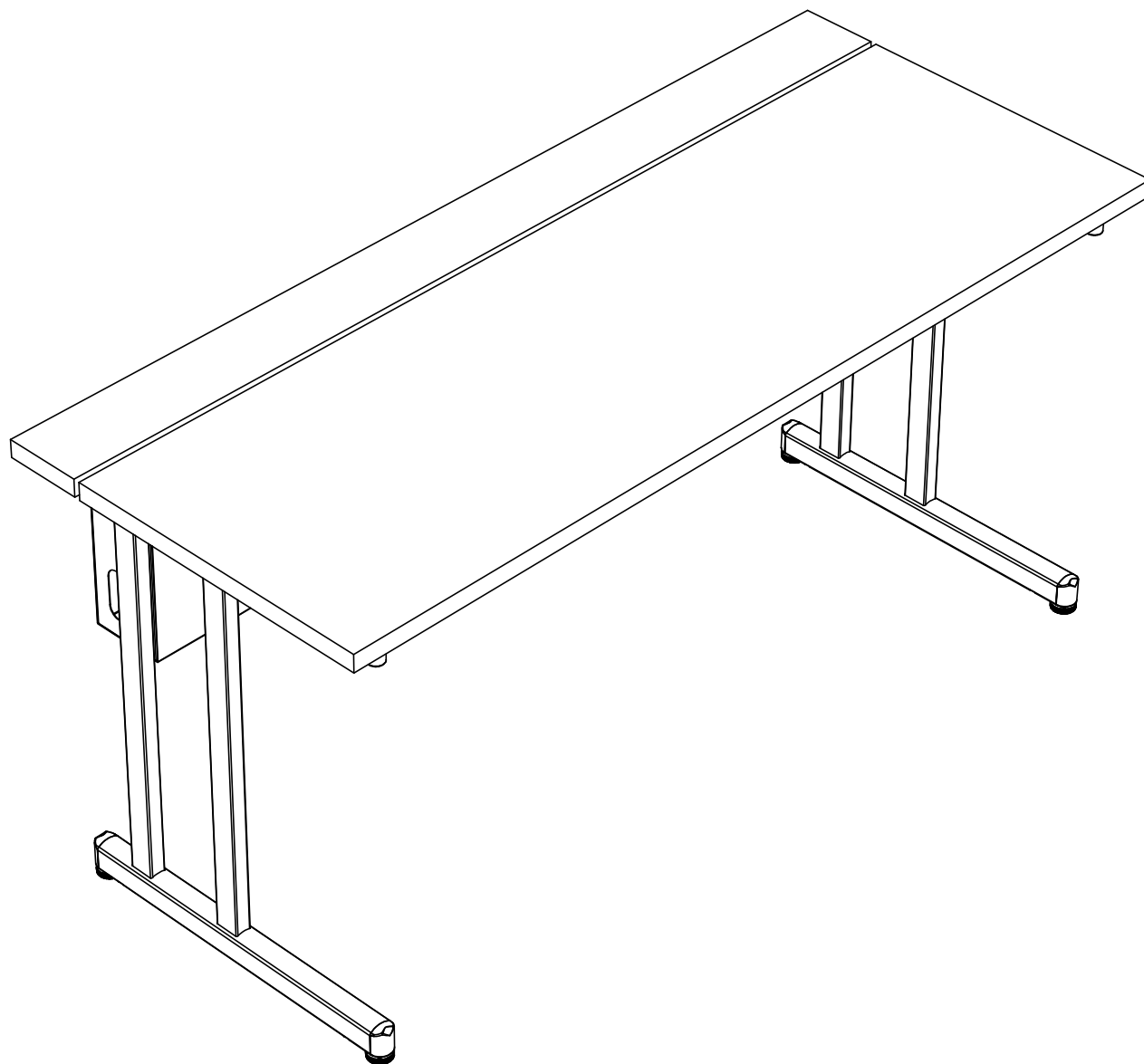

**R-Style Delta Assembly Instructions**  
**Warranty: [raproducts.com/warranty](http://raproducts.com/warranty)**





Power Driver with Adjustable Torque



#2 Phillips Head Driver Bit



#2 Square Head Driver Bit

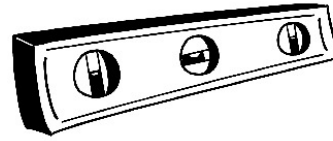

Level

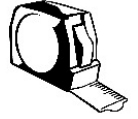

Tape Measure

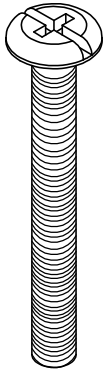

1

M6-1x50 x4

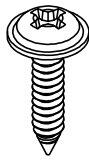

2

M5x18 x16

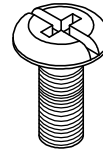

3

M6x15 x 6



4

Clear Bumper x 2

**1**

Thread these screws part way in leaving a gap of about 1/8". Repeat with the other leg.

3

Left and right leg assemblies

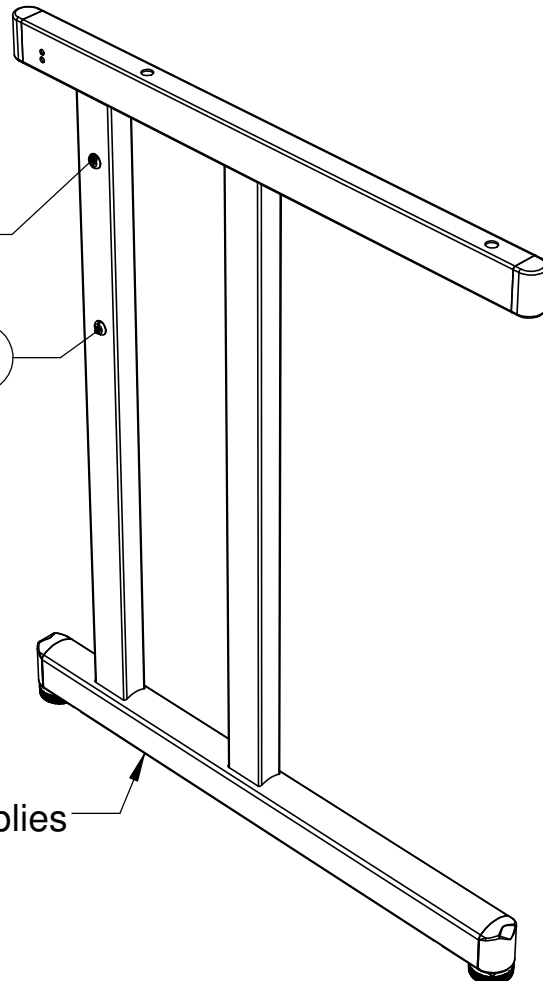

- 2** Insert the screws you threaded into the leg assemblies through the keyhole slots on the ends of the cable tray. Drop the tray into place and tighten the screws.

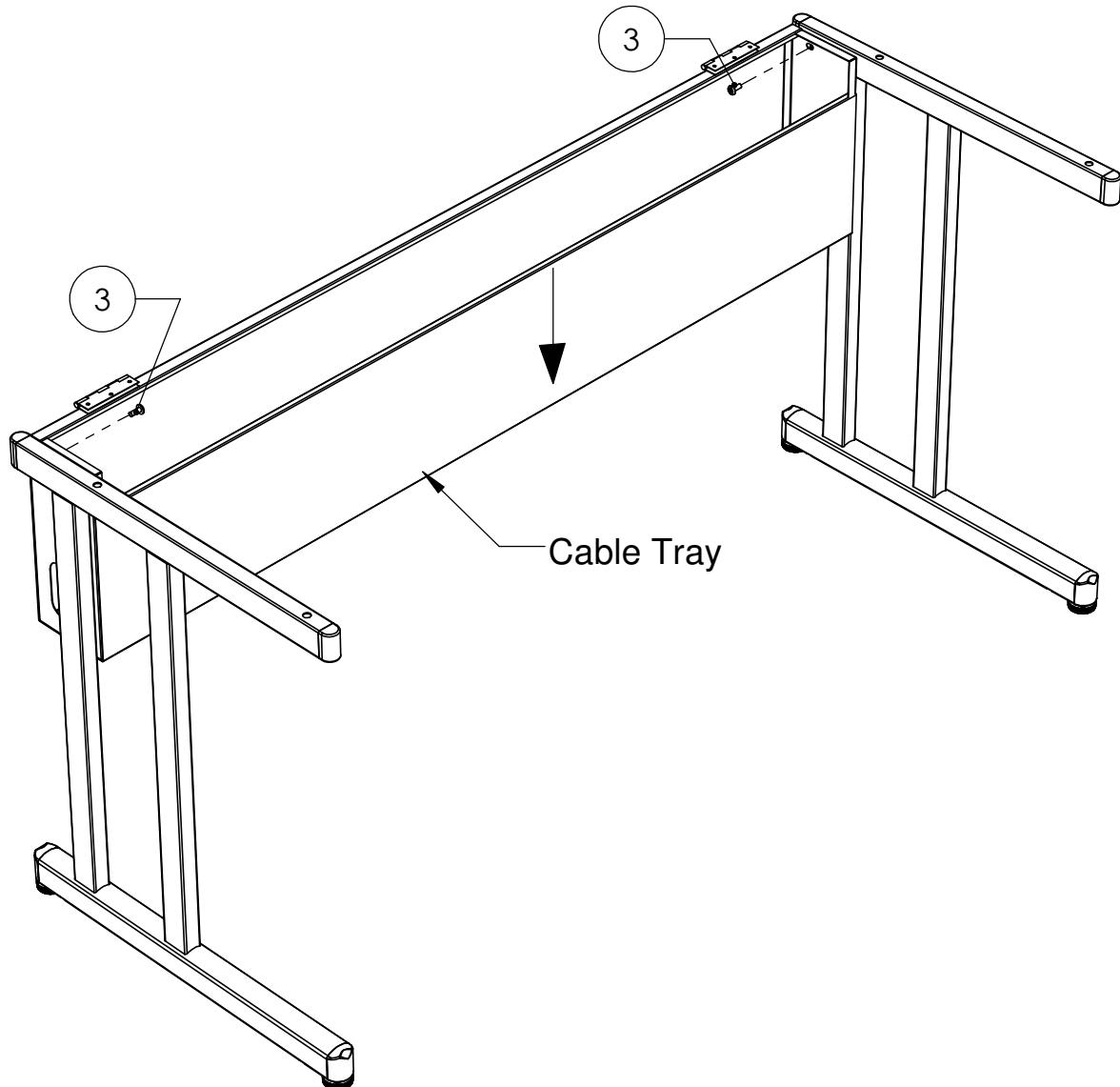

- 3** Add another two screws **4** and tighten them.

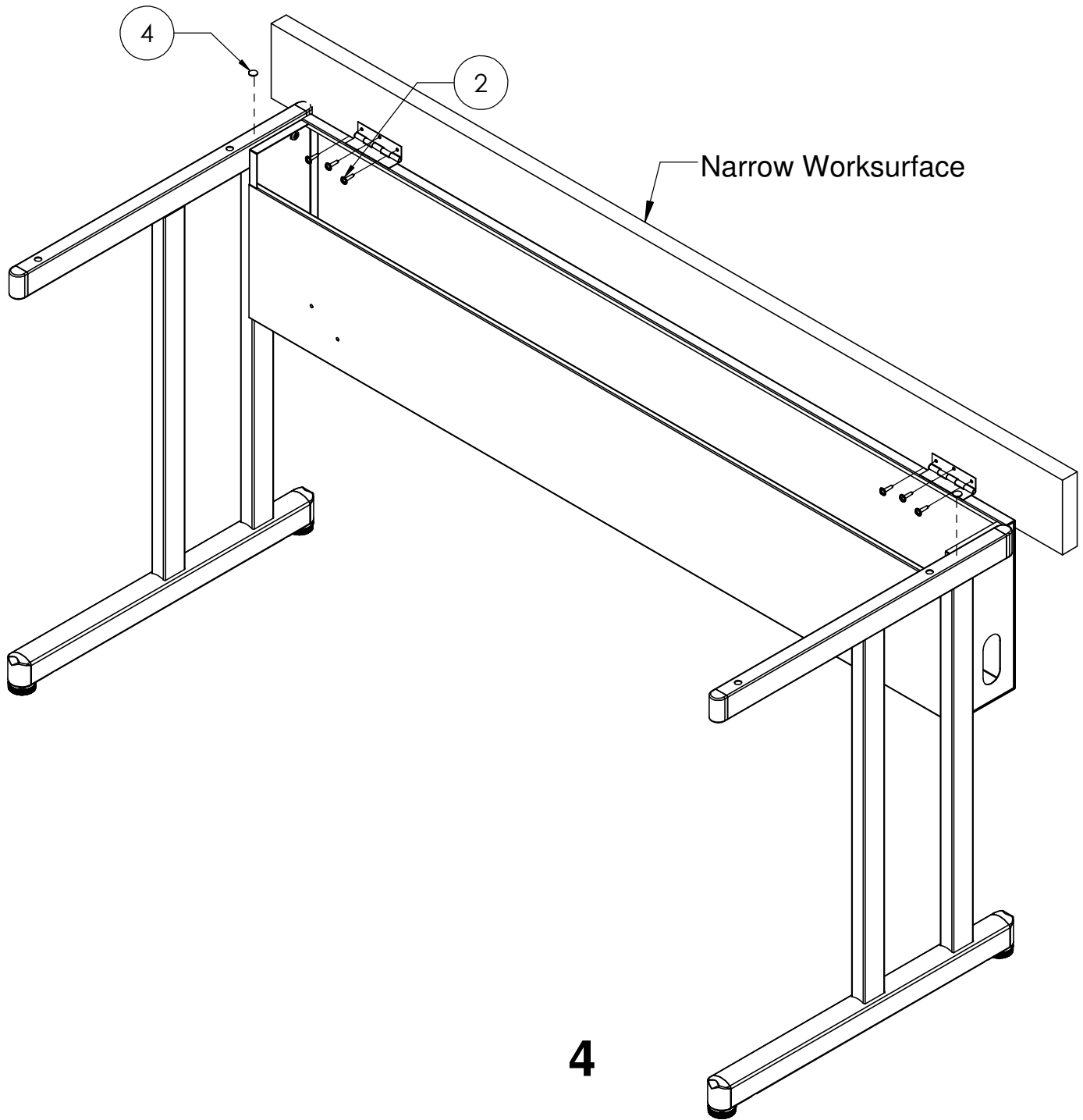

NOTE: IF YOUR WORKSURFACE LENGTH IS 60" OR GREATER, A U-CHANNEL WILL NEED TO BE INSTALLED.  
60" AND UNDER DO NOT REQUIRE A U-CHANNEL. SKIP TO STEP 6

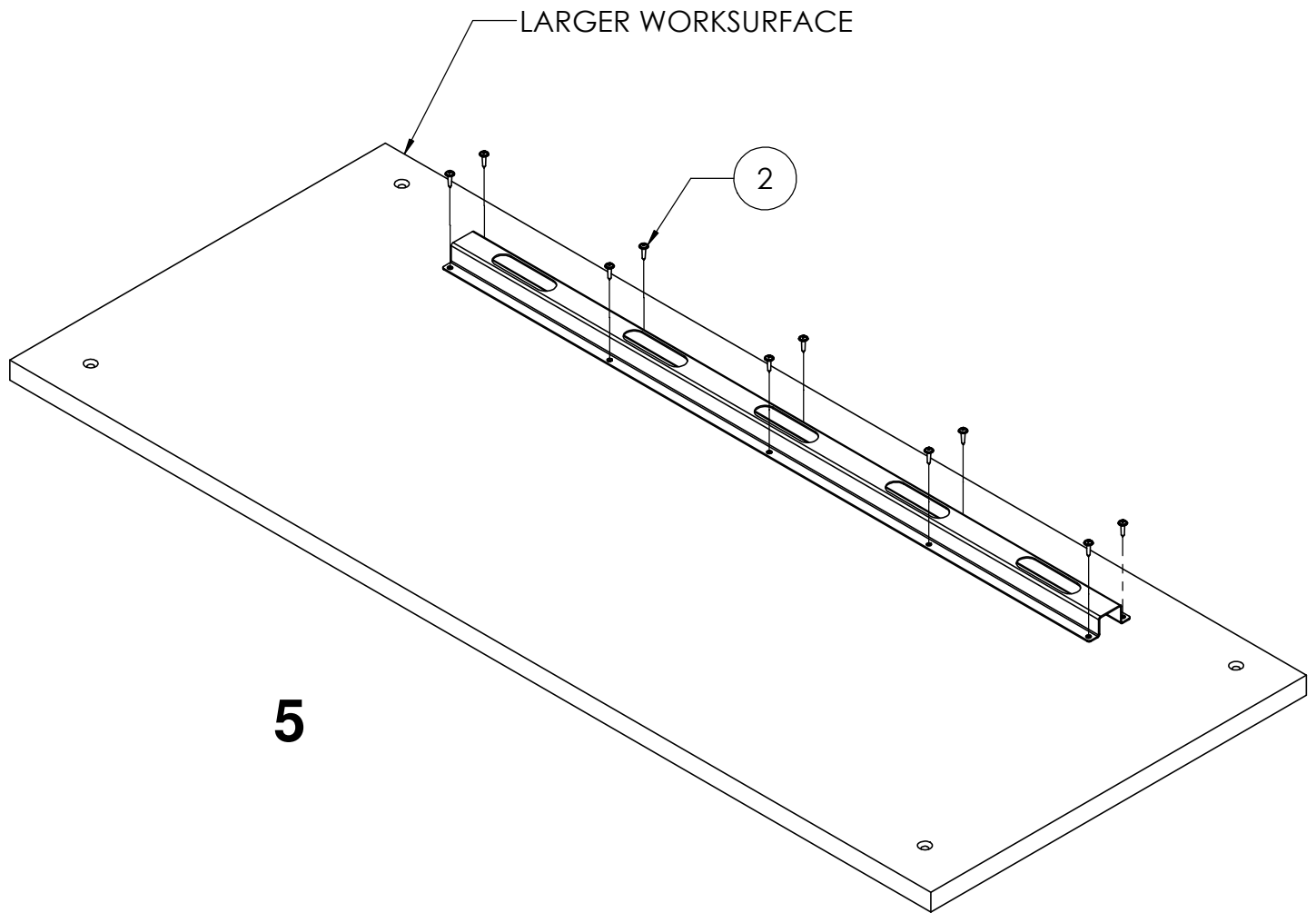

ALIGN U-CHANNEL WITH PILOT HOLES AND ATTACH WITH WOOD SCREWS.

