



Operator's Manual

PGD3875



Table of Contents

Introduction.....	2
Safety Warnings	3
Main Parts.....	4
Preparation For Use.....	5
Operating Instructions.....	7
Service and Maintenance.....	8
Troubleshooting.....	12
Key Product Data.....	13
Parts Diagram.....	14
Warranty.....	19
Contact Info.....	20

Introduction

Thank you for choosing Titan Gas-Powered Post Drivers. The performance of this machine is dependent upon your knowledge of the information contained in this operator's manual and your understanding of the operation and care of the engine installed on your Titan Post Driver.

Your Titan Post Driver comes with a one-year limited manufacturer's warranty (see warranty terms on Page 19 of this manual). We suggest that you read the warranty information and fully understand its coverage and your responsibilities of ownership. To register your Titan Post Driver, simply fill out and return the warranty registration card enclosed with your machine.

Please contact Titan Post Drivers at (702) 293-4262 for parts or technical questions related to your post driver warranty.



Titan PGD3875 Post Driver

Safety Warnings

1. Always follow proper operation and maintenance instructions.
2. Always use approved Personal Protective Equipment (PPE). Operators and all other persons in the immediate working area must wear protective equipment as well. Noise emitted from the machine while working can reach above 100 decibels, which can also harm others in close proximity. We recommend the following personal protective equipment:
 - a. Class 4 (SLC80 = 22.4 dB) hearing protection or greater
 - b. Impact-resistant eye protection with side guards
 - c. Protective gloves
 - d. Protective boots
3. Always check fastening screws before use. If they are loose, tighten them.
4. Always check the spark plug before use. If it is exposed, it must be covered by a high-voltage cap. Check the flameout line and pipes for damage. If damaged, repair or change them before use.
5. Keep the handle clean and dry.
6. Do not add too much fuel. The fuel level should not exceed the neck of the fuel tank. If accidental overfilling occurs, pour fuel out until the fuel level is within the proper range within the fuel tank. There should not be any fuel on the surface of the machine. ALWAYS wipe your post driver clean after refueling. Only start the post driver after any excess fuel has evaporated completely.
7. After refueling, tighten the fuel lid. Be sure to check for fuel leaks or damage to the fuel tank. If damage is found, turn off the post driver immediately, and do not operate it until the damage is repaired.
8. Never use this post driver inside a building or unventilated area. The engine exhaust contains poisonous carbon monoxide gas that can build up to dangerous levels in closed areas. These fumes can cause unconsciousness or death.
9. Do not use the post driver in adverse weather conditions such as thunderstorms, heavy fog, or strong wind.
10. While operating the post driver, maintain good balance and operate the machine vertically. The operator should stand in front of the air filter and front-operate the machine.
11. Do not operate the post driver with one hand or turn the machine upside down horizontally. ALWAYS use two hands and correct posture when operating the driver.
12. When transporting the post driver, turn it off.
13. Never let your post driver run unattended, and keep unauthorized persons away from the operation area.
14. While operating the post driver, be sure the contact surface of the post is smooth and flat and the diameter of the post is within the limit of the post driver barrel (3.925").
15. Avoid quick acceleration or braking so you do not damage the machine.
16. During operation, do not let the air vent of the muffler face people. The high-temperature exhaust gas can cause serious injury.
17. To avoid being burned, do not touch the muffler, engine cylinder, barrel, hammer case, gearbox, etc. after operation. These parts will be very hot and can cause serious injury.
18. Gasoline is highly flammable. Therefore, replenish fuel in a well-ventilated area. ALWAYS turn off the engine before refueling.
19. Store fuel in a proper area that is free from fire hazards.
20. Before transport, empty the fuel inside the fuel tank to avoid leakage.
21. Non-professional maintenance staff are prohibited from dismantling this post driver in order to avoid accidents, structural damage of parts, and /or shortened service life.

Main Parts

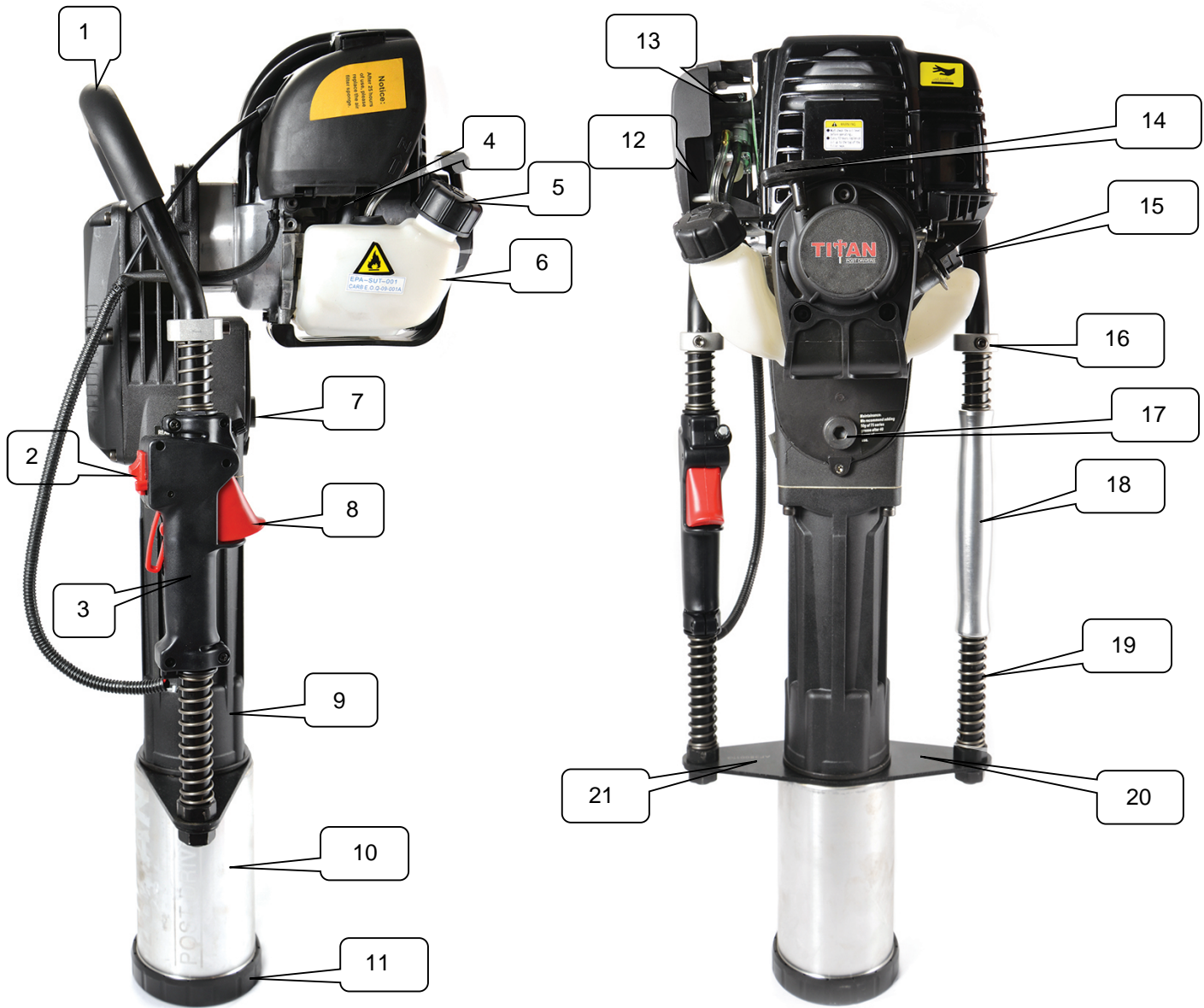

No.	Part Name	No.	Part Name	No.	Part Name
1	Carrying Handle	2	Stop Switch	3	Combination Switch
4	Fuel Bubble	5	Fuel Tank Lid	6	Fuel Tank
7	Regulating Switch	8	Throttle Switch	9	Hammer Case
10	Timber Guide Sleeve	11	Timber Guide Sleeve Retainer	12	Choke
13	Air Filter	14	Starter	15	Oil Level Gauge
16	Positioning Sleeve	17	Grease Plug	18	Handle
19	Dampening Spring	20	Support Plate	21	Serial Number Location

Preparations For Use

Installing Inner Pile Head

If the inner pile head (#40) is not pressed on the shock (#35) at this time, you must slide the inner pile head inside the piling socket and match the small side with the shock. Tap the inner pile head a few times to make sure it is connected to the shock. As you start using your machine, the inner pile head will press further on the shock and will not separate again without the use of tools.

Installing Piling Socket Sleeve

Before use, install the correct piling socket sleeve for your application as shown below:

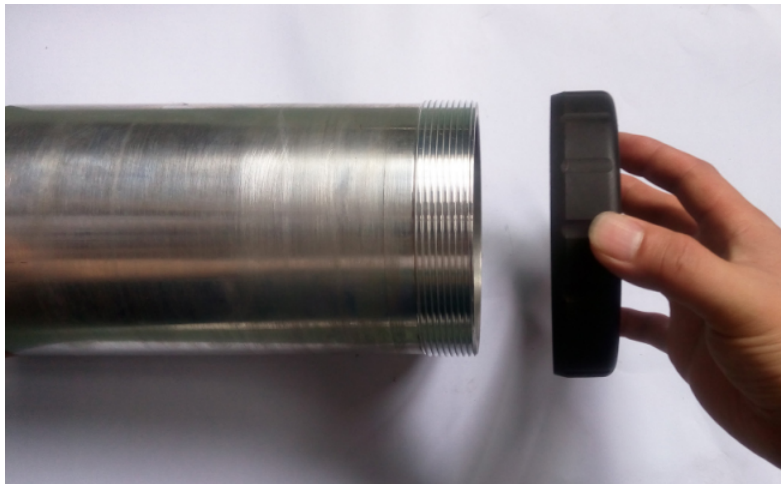

Adding Fuel

1. Always turn the engine off and allow adequate time for it to cool before refueling. Only use unleaded fuel with 86 octane or higher.
2. Never refuel your driver with the engine hot, running, or in an unventilated area. Fuel vapors are extremely flammable and can cause severe injury or death if ignited by a spark or excessive heat from a hot engine.
3. Do not add too much fuel. The fuel level should not exceed the neck of the filler fuel tank. If accidental overfilling occurs, pour fuel out until the fuel level is within the proper range within the fuel tank. There should not be any fuel on the surface of the machine. ALWAYS wipe your post driver clean after refueling. Only start the post driver after any excess fuel has evaporated completely.
4. After refueling, tighten the fuel tank lid.
5. This post driver uses pure gasoline as fuel. Do not use gasoline mixed with oil. This will result in poor starting performance and low function.

Adding Engine Oil

1. Before the first use, add engine oil. **THE OIL IS NOT FILLED WHEN THE POST DRIVER IS ASSEMBLED.** We recommend adding less than 80 cm³ (2.7 US oz., 2.8 Imp. oz.), then checking. Add oil if required to fill to the bottom edge of the oil fill hole. Use 10W-30 oil. **DO NOT OVERFILL.** Always hold driver in upright position to check oil level. Proper oil level is essential for the correct operation of the post driver. Overfilling the oil will result in loss of power and could cause permanent damage to your engine.
2. To avoid damage to the engine, always check the engine oil before starting the driver. Be sure the engine oil level is adequate.
3. For every 10 hours of use, it is necessary to check the oil level.
4. To check the oil, place the driver in the vertical position by standing it on the piling socket. Unscrew the oil level gauge, and check the oil level as shown below. If the oil level is low, add oil. If the oil is dirty, change the oil.

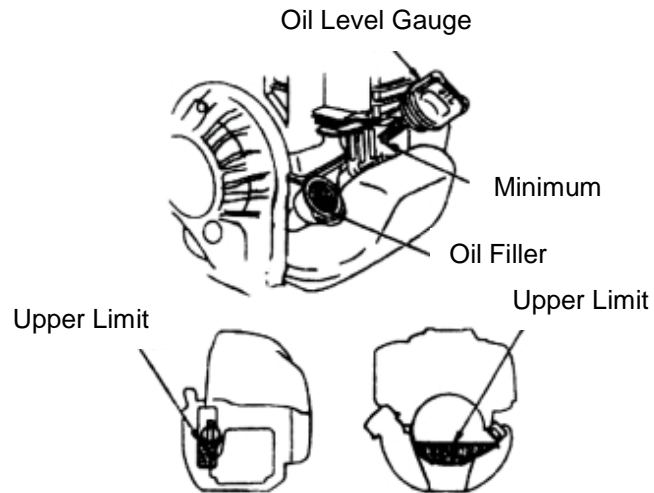

The recommended environmental temperature range of the machine is 5° to 105° F. We recommend the use of SAE 10W-30 engine oil, which equals to API classification SJ. See SAE Engine Oil Consistency Table below.

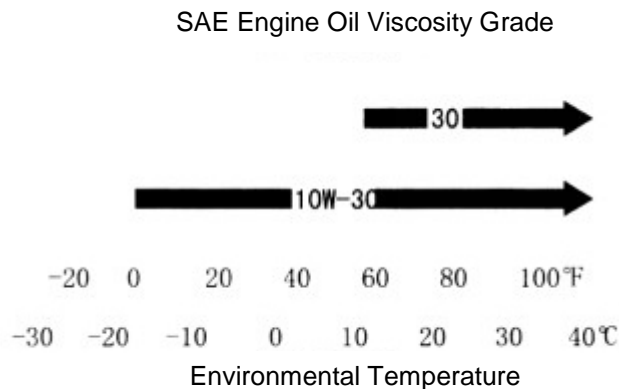

Checking the Air Filter

1. Remove the air filter cover, and check to see if the air filter is clean. If it is dirty, clean it.
2. After checking the air filter, reinstall the air filter cover.

Operating Instructions

Starting

1. The engine on the PGD3875 is inclinable, which means it can be stored and operated in any direction. BEFORE STARTING, the driver needs to be in the horizontal position for 5 minutes.
2. Before starting the post driver, press the transparent, semi-circle fuel bubble repeatedly until the carburetor is filled with fuel. If the engine is cool, place the choke lever to the "on" position.
3. Place one hand on the top engine cover with slight downward pressure. With your other hand, pull the starter rope about 20" quickly.
4. AFTER the engine has started, place the choke lever completely to the "off" position. AFTER IDLING FOR 5 MINUTES, start normal work.
5. While the post driver is running, don't pull the starter rope. The high-speed rotating parts may damage the starter.

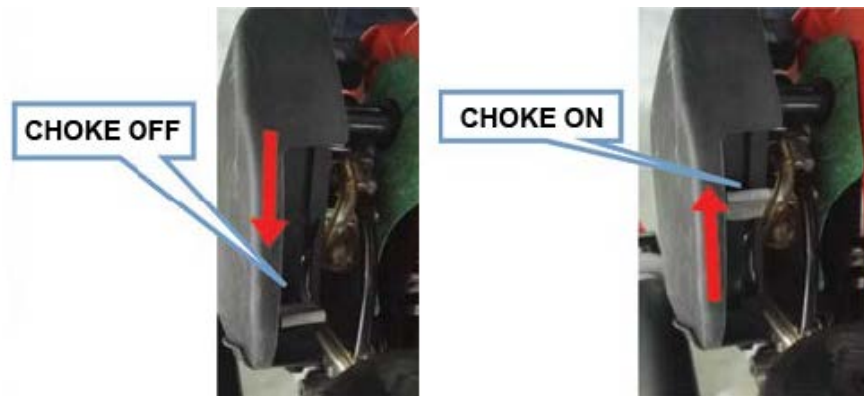

Operating

1. After the engine is started, ALLOW IT TO IDLE FOR 5 MINUTES BEFORE USE.
2. For a brand new driver, ONLY PERFORM LOW TO MEDIUM-SPEED WORK FOR THE FIRST 24 HOURS OF USE in order to break in the engine and prolong the life of the machine.
3. For a brand new driver, it may take 2 to 3 minutes of post driving for the machine to begin running at a normal performance level.
4. Do not operate the driver at a high speed when you are not driving posts.

Turning Off the Machine

1. Release the throttle trigger and ALLOW THE MACHINE TO IDLE FOR 3 TO 5 MINUTES.
2. Push the stop switch to the off position (see below).

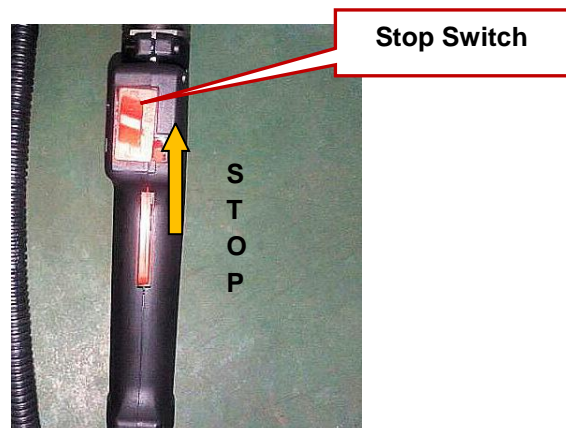

Service and Maintenance

Air Filter Maintenance

After the air filter has been used for some time, dirt attached to the filter element influences air intake and results in reduced power and increased oil consumption. It is necessary to clean the air filter regularly. The cleaning cycle is usually every 3 months or every 25 hours of operation. When using the driver in extremely dusty environments, clean it every 10 hours or even every day.

Cleaning the Air Filter

1. Remove the air filter cover, and take out the air filter.
2. Put the air filter into water. Squeeze the water out of the filter and allow it to air dry.
3. Put it in clean oil and rub gently. Take it out and squeeze it dry.
4. After cleaning, assemble the air filter and the air filter cover.



Fuel Filter Maintenance

If the fuel filter is blocked, the post driver will have reduced speed and weaker impact energy.

1. Open the tank lid.
2. Remove the fuel filter from the fuel tank with a metal hook and clean it.
3. When cleaning the fuel filter, clean the fuel tank at the same time as shown below.



Carburetor Maintenance

The fuel tank and the carburetor generally have residual fuel. Over time, the residual fuel can block up the fuel line causing the engine not to start. Therefore, when the machine is not used for more than one week, be sure to completely remove the fuel.

1. To remove fuel, pull out the fuel inlet pipe and press the rubber carburetor fuel bubble repeatedly for fuel discharge.
2. Press the fuel inlet pipe back into position when the fuel in the fuel bubble and fuel return pipe is emptied.

Spark Plug Maintenance

If the spark plug has too much carbon deposit, it will result in poor engine performance. It is necessary to regularly maintain and adjust the spark plug every year or every 100 hours of operation.

1. Take apart the spark plug as shown below.
2. Remove carbon deposit.
3. Adjust to 0.6 – 0.7 mm.
4. Screw spark plug tight.

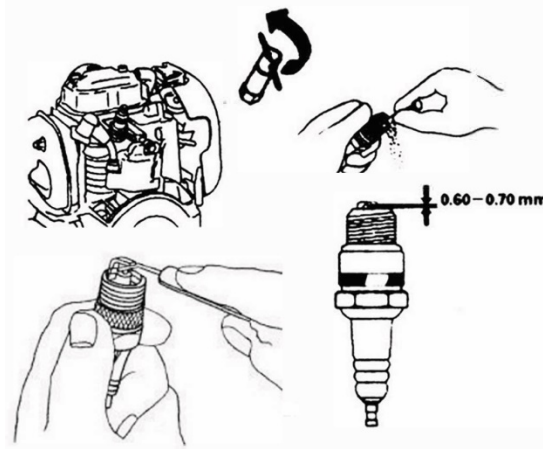

Replacing Engine Oil

1. Unclean engine oil will result in reduced service life of moving engine parts. It is necessary to regularly replace engine oil and keep engine oil at proper levels.
2. Replace engine oil every 6 months or after 50 hours of operation.
3. Drain the oil when the engine is hot to guarantee that engine oil can be emptied quickly and completely.
4. Replacing engine oil:
 - a. Ensure that the cap of the fuel tank is screwed tight.
 - b. Place a proper container near the engine for storing waste engine oil.
 - c. Remove the engine oil gauge, lean the engine toward the engine oil filler, and discharge engine oil to the container as shown below.
 - d. Place the engine horizontally and add the recommended oil to the bottom edge of the oil filler. Refer to page 6 for adding the correct amount of engine oil.
 - e. After engine oil is discharged, there is some residual oil in the engine. If the residual oil is less than 100 mL, add new engine oil slowly to the bottom edge of the oil filler.

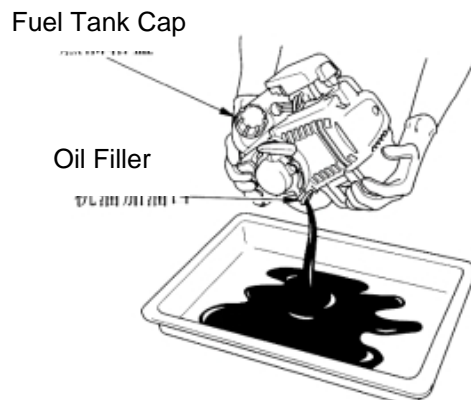

The recommended environmental temperature range of the machine is 5° to 105° F. We recommend the use of SAE 10W-30 engine oil, which equals to API classification SJ.

Lubrication of Gearbox and Impact Parts

After 40 hours of use, open the gearbox cover, and add 75 Series Grease to the connecting rod to fully lubricate the machine as shown below.

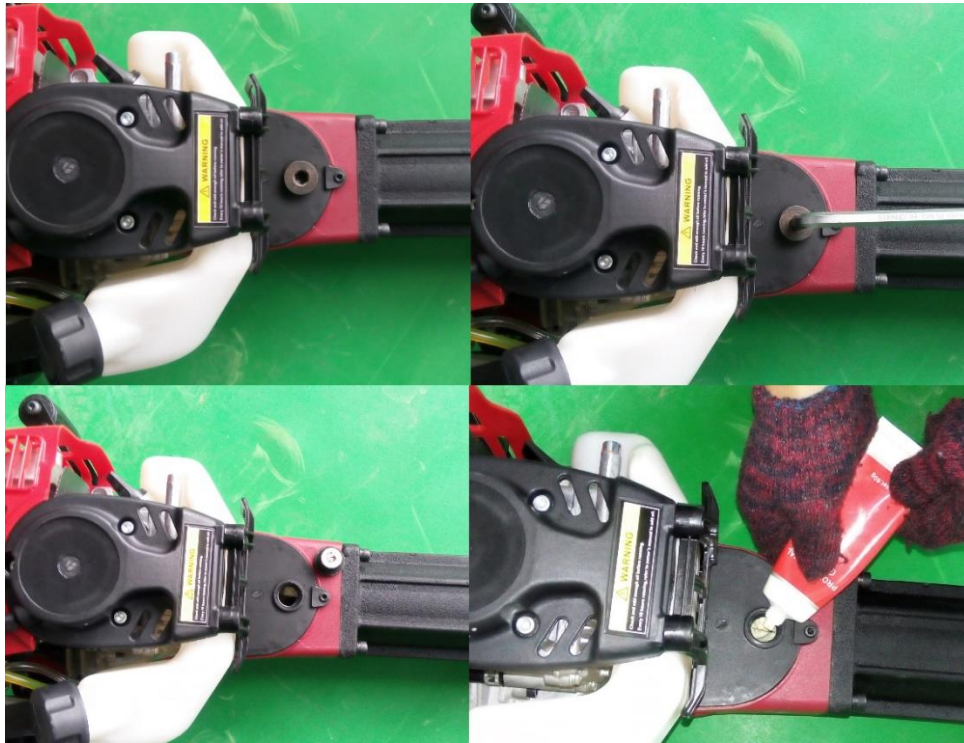

Maintenance Schedule

This schedule is based on operating the post driver under normal conditions. Under more strenuous conditions, such as a dusty environment or long work hours, the maintenance cycle should be adjusted accordingly.		Before Each Use	After Each Use or Every Day	After Filling Oil	Every Week	Every Month	If Temporary Failure	If Necessary
The Whole Machine	Outlook Check (state, tightness of screws)	√		√				
	Clean		√					
Control Handle/Stop Button	Function Check	√		√				
Air Filter	Clean				√			√
	Replace						√	
Fuel Filter	Check					√		
	Replace						√	
Fuel Tank/Fuel Tank Lid	Clean		√	√				
	Check	√		√				
	Tighten							√
Reduction Gearbox/Impact Cylinder	Clean					√		
	Add Grease							√
Muffler	Check					√		
	Remove Carbon Deposit							√
Cylinder Cooling Fin	Check					√		
	Clean							√
Spark Plug	Check/Adjust					√		
	Replace							√
Screw and Nut	Check	√		√				
	Tighten							√

Troubleshooting

Example 1: Difficulty starting the engine in a cooled state.

1. Is the spark plug damp?
 - a. If yes, dry the spark plug.
2. If no, does the spark plug produce a spark?
 - a. If no, replace the spark plug.
3. If yes, check to see if too much fuel has been absorbed.
 - a. If too much fuel has been absorbed, reduce the fuel supply.

Example 2: Difficulty starting after a sudden stop.

1. Is the fuel tank empty?
 - a. If yes, add fuel.
2. If no, is the carburetor blocked?
 - a. If yes, clean carburetor.
3. If no, is the fuel filter blocked?
 - a. If yes, clean the fuel filter.
4. If no, is there too much carbon deposit on the spark plug?
 - a. If yes, clean the spark plug.

Example 3: Slow speed and weak power.

1. Is there too much carbon deposit on the cylinder or silencer?
 - a. If yes, clean the cylinder or silencer.
2. If no, is the fuel line and air vent of the fuel tank blocked?
 - a. If yes, clean the fuel line and air vent of fuel tank.
3. If no, is the air filter blocked?
 - a. If yes, clean the air filter.

Example 4: Post driver is making abnormal sounds.

1. Have you increased the engine RPMs, above idle, without your driver being in contact with a post?
 - a. If yes, with the driver on your post, lift up a few inches and strike back down to make sure shock is fully engaged.
2. Is there too much carbon deposit in the combustion chamber?
 - a. If yes, clean the combustion chamber.
3. If no, is there serious abrasion on active components?
 - a. If yes, replace them.

Example 5: The post driver is working normally, but efficiency is low.

1. Is there 2-3 tablespoons of grease visible in the impact cylinder?
 - a. If no, add a half bottle of 75-series grease to impact cylinder (page 10.)
2. Is the rubber ring of the impact piston old and worn out?
 - a. If yes, replace the rubber ring of the impact piston.

If these steps do not address your issue, call Titan Post Drivers at **(702) 293-4262** for further assistance.

Key Product Data

Engine Type	4-stroke, single-cylinder, air-cooled 140FA gasoline engine
Model	PGD3875
LxWxH (inches)	32" x 12" x 10"
Fuel	86 octane, unleaded gasoline or higher
Displacement	37.7 cc
Fuel Tank Volume	0.17 US gal
Oil Capacity	2.71 US oz
Weight	50 pounds
Max Power and Corresponding Rotating Speed	1.3 hp / 6,500 r/min
Max Torque and Corresponding Rotating Speed	1.2 ft/lb / 5,500 r/min
Fuel Consumption Rate	≤ 0.19 US gal/hr
Impact Frequency	700 – 1,350 bpm
Impact Energy	Up to 41 ft lbs
Spark Plug Type	CMR5H
Starter System	Hand-pull start

Parts List and Exploded View of PGD3875 Driver

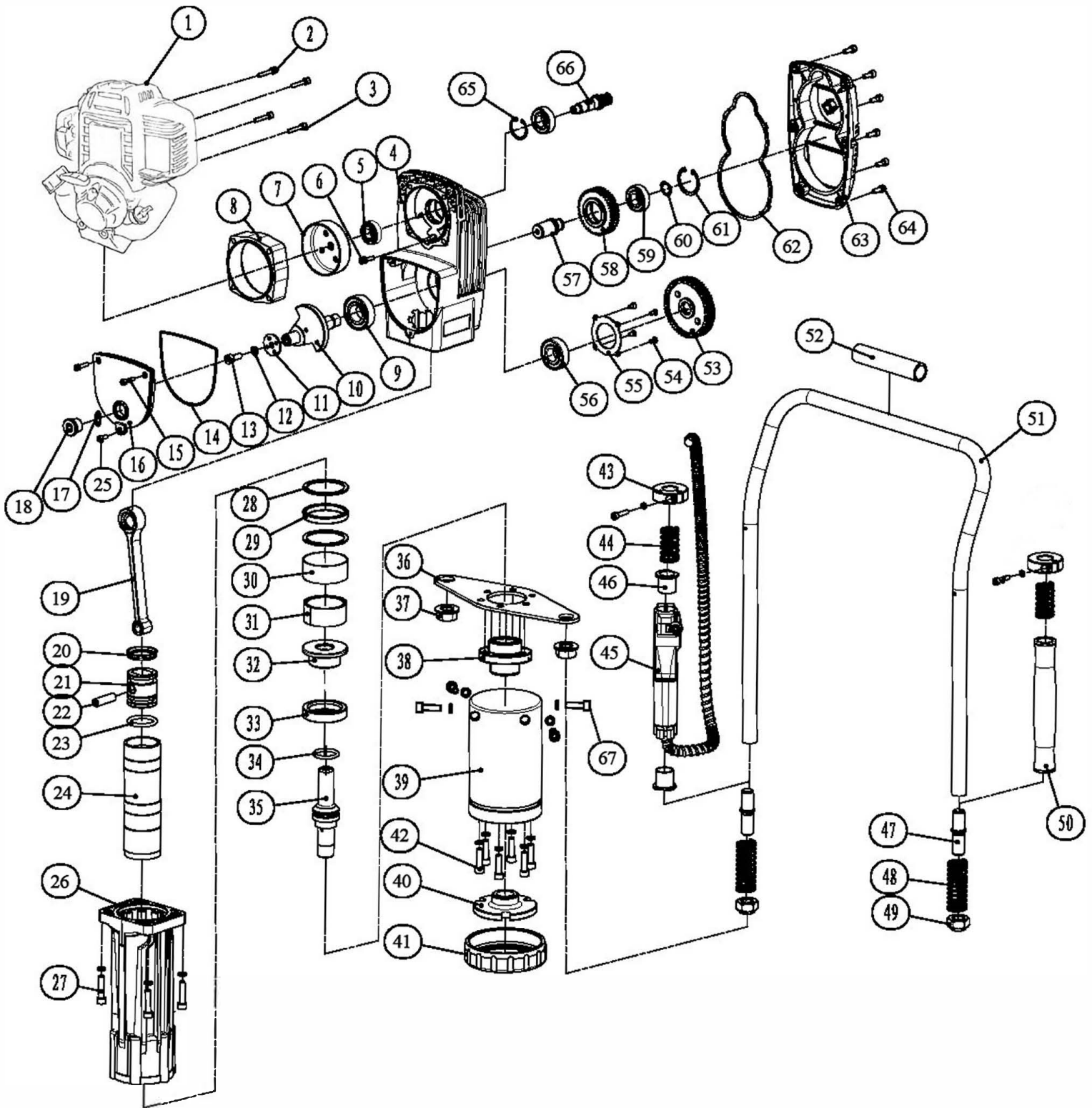

Parts List and Exploded View of PGD3875 Post Driver

No.	Name	Qty	No.	Name	Qty
1	Huasheng 140FA Gasoline Engine	1	41	Piling Socket Retainer	1
2	Inner Hexagon Cheese-head ScrewM6×50	2	42	Inner Hexagon Cheese-head Screw M8x40	6
3	Inner Hexagon Cheese-head ScrewM6×45	2	43	Positioning Sleeve	2
4	Gearbox	1	44	Compression Spring Φ22.5×Φ27.5×60	2
5	Deep Groove Ball Bearings 6202-2RZ	1	45	Combination Switch	1
6	Inner Hexagon Cheese-head ScrewM6×25	1	46	Switch Handle Guide Sleeve	2
7	Driven Disk	1	47	Connecting Thread Head	2
8	Connection Block	1	48	Compression Spring Φ22.5×Φ27.5×123	2
9	Deep Groove Ball Bearings 6205-2RZ	1	49	Step Nut	2
10	Impact Crankshaft	1	50	Handle Sleeve	1
11	Crankshaft Retainer	1	51	Steel Tube Handle	1
12	Elastic Washer 8×2.1	1	52	Handle Cushion	1
13	Inner Hexagon Cheese-head ScrewM8×20	1	53	Big Gear	1
14	Grease Storage Box Seal	1	54	Cross Recessed Countersunk Head Screw M5×10	4
15	Inner Hexagon Cheese-head ScrewM5×20	2	55	Bearing Holder	1
16	Grease Storage Box Lid	1	56	Deep Groove Ball Bearings 6204-2RZ	1
17	O-ring Φ18×2.65	1	57	Gear Shaft	1
18	Grease plug M20×1.5	1	58	Middle Gear	1
19	Impact Connecting Rod	1	59	Deep Groove Ball Bearings 6203-2RZ	2
20	Lip-shaped Ring Φ35.5×Φ45.5×6	1	60	Shaft Retainer 17	1
21	Impact Piston	1	61	Hole Retainer 40	1
22	Impact Piston Pin	1	62	Gearbox Cover Seal	1
23	O-ring Φ35.5×5	1	63	Gearbox Cover	1
24	Impact Cylinder	1	64	Inner Hexagon Cheese-head ScrewM6×16	6

25	Inner Hexagon Cheese-head ScrewM5×16	1		65	Hole Retainer 35	1
26	Aluminum Hammer Case	1		66	Small Gear	1
27	Inner Hexagon Cheese-head ScrewM8×35	4		67	Inner Hexagon Cheese-head Screw M8x20	4
28	Iron Ring	2				
29	Small Vibration Absorption Ring	1				
30	Opening Ring Rubber Circle	1				
31	Opening Ring	1				
32	Iron Sleeve	1				
33	Big Vibration Absorption Ring	1				
34	O-ring Φ33×4	1				
35	Shock	1				
36	Support Plate	1				
37	Hexagon Flange Nut M18×1.5	2				
38	Shock Guide Sleeve	1				
39	Piling Socket	1				
40	Inner Pile Head	1				

Exploded View of 140FA Engine

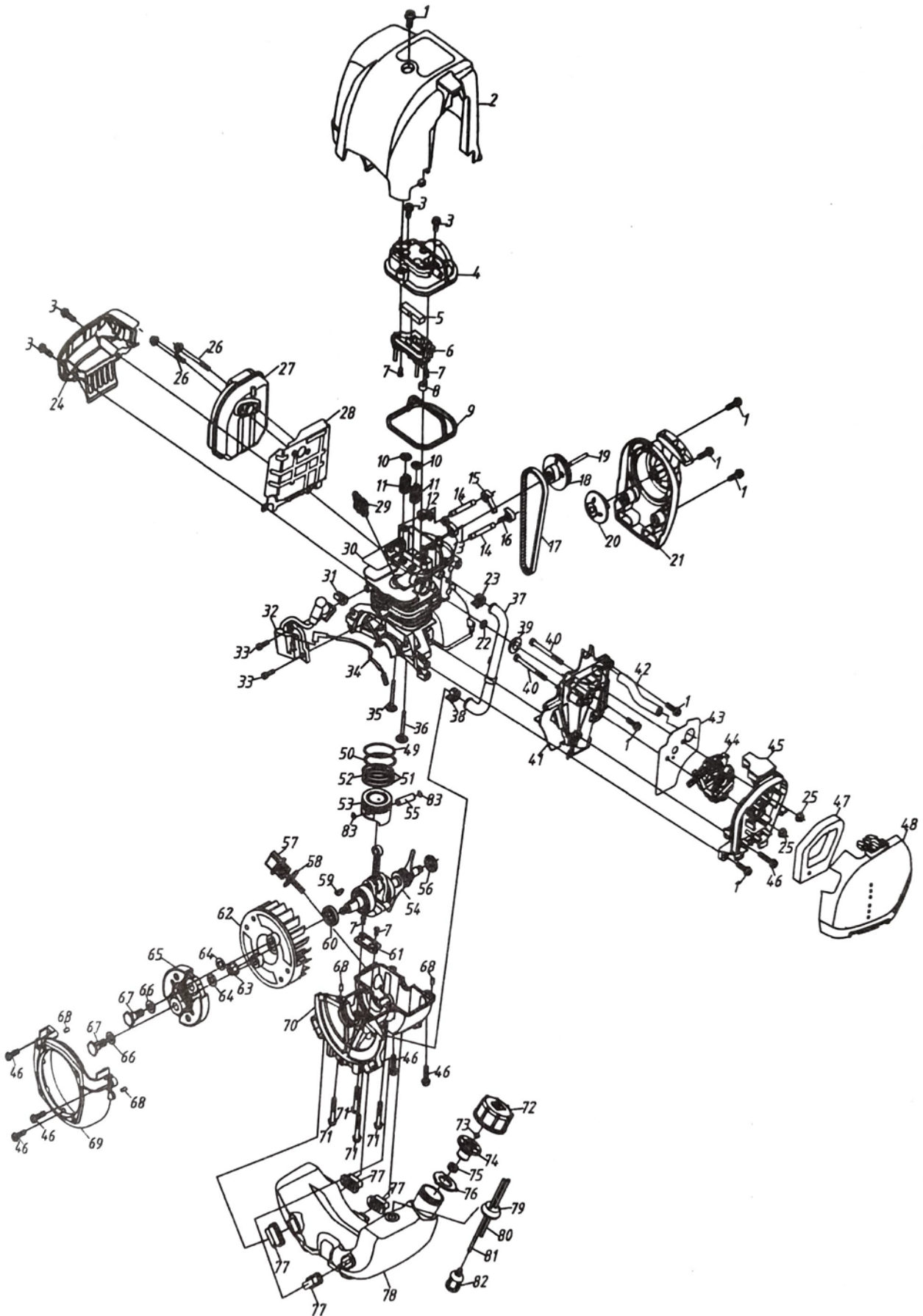

Parts List and Exploded View of 140FA Engine

Parts No.	Name	Qty	Parts No.	Name	Qty
1	Socket M5X15	7	43	Carburetor Gasket	1
2	Cover	1	44	Carburetor	1
3	Socket M5x12	3	45	Air Cleaner Housing	1
4	Cylinder Head Cover	1	46	Socket M5x22	6
5	Filter	1	47	Filter Element	1
6	Inner Head Cover	1	48	Air Cleaner Cover	1
7	Screw M4x8	4	49	First Piston Ring	1
8	Head Cover Grommet	1	50	Second Piston Ring	1
9	Head Cover Seal	1	51	Oil Rings	2
10	Valve Spring Retainer	2	52	Cushion Spring	1
11	Valve Spring	2	53	Piston	1
12	Exhaust Valve Rocker	1	54	Crankshaft Assembly	1
13	Intake Valve Rocker	1	55	Piston Pin	1
14	Rocker Arm Pin	2	56	Oil Seal	1
15	Exhaust Valve Lifter	1	57	Oil Level Gauge	1
16	Intake Valve Lifter	1	58	O-Shaped Seal Ring 14x2.65	1
17	Timing Belt	1	59	Woodruff Key 3x5x13	1
18	Cam Gear	1	60	Oil Seal	1
19	Cam Pin Roller	1	61	Oil Valve	1
20	Recoil Starter Pulley	1	62	Flywheel	1
21	Starter Assembly	1	63	Nut M8	1
22	Intake Pipe Flat Gasket	1	64	Spacer	2
23	Clamp	1	65	Clutch	1
24	Air Guide	1	66	Clutch Washer	2
25	Flange Nut M5	2	67	Clutch Bolt	1
26	Stud Bolt	2	68	Pin B4x8	4
27	Muffler	1	69	Fan Cover	1
28	Air Exhaust Guide	1	70	Lower Crankcase	1
29	Spark Plug	1	71	Socket M5x32	4
30	Cylinder Block	1	72	Fuel Tank Cap	1
31	Ignition Wire Clamp	1	73	Intake Nozzle	1
32	Ignition Coil Assembly	1	74	Inner Cap	1
33	Socket M4x14	2	75	End Cap	1
34	Stop Wire	1	76	Gasket	1
35	Exhaust Valve	1	77	Rubber Shock Absorber	4
36	Intake Valve	1	78	Fuel Tank	1
37	Oil Tube	1	79	Fuel Line Grommet	1
38	Clamp	1	80	Fuel Return Tube	1
39	Intake O-Ring	1	81	Fuel Inlet Tube	1
40	Bolt M5X55	2	82	Fuel Filter	1
41	Intake Shroud	1	83	Piston Pin Retainer	2
42	Breather Tube	1			

Warranty

Titan Post Drivers will warrant to the original purchaser, who purchases the equipment in new condition and in its original packaging from an authorized dealer, that its gas-powered post driver will be free from defects in workmanship and materials for a period of one (1) year. This warranty period will commence on the date of retail purchase by the original purchaser. This warranty is non-transferrable beyond the original purchaser.

- Warranty shall pertain to parts or service offered by an authorized Titan Post Drivers dealer. Any defective part replaced at an authorized Titan Post Drivers location becomes the property of Titan Post Drivers.
- Shipping costs to transport the machine to the service center for warranty work will be the responsibility of the consumer.
- Titan Post Drivers will pay for return shipping to the customer within the Contiguous US.
- For warranty claims, contact Titan Post Drivers with proof of purchase date and your serial number.

Limitations of Warranty

This limited warranty does not extend to any Titan Post Drivers product which has been misused, abused, or improperly maintained, altered, or repaired by an unauthorized person. Nor does this limited warranty cover any damage to machine or parts due to faulty installation of parts, faulty operation, or faulty maintenance. Plastic carrying cases and reducer sleeves are not covered under this warranty.

- Damage to components caused by operator error such as dry-fire or misfire will not be considered for warranty replacement or service.
- Damage to cosmetic parts caused by rough handling, operator error, or improper storage and handling will not be considered for warranty replacement or service.
- Excluded components that may need replacement or repair due to normal wear and tear, or lack of proper use/maintenance include:
 1. O-rings and seals
 2. Lost or stripped fasteners
 3. Barrel of driver from incorrect use of machine
 4. Titan Post Drivers sleeves/accessories

Disclaimer of Warranty

Titan Post Drivers disclaims all liability for any implied warranties. Under no circumstances shall Titan Post Drivers be liable for any loss of business, revenues, profit, or indirect, incidental, special, or consequential damages or loss arising out of any defect in, or performance of, Titan Post Drivers products, howsoever caused.



Contact:

Hours: Monday-Friday 8 AM to 5 PM CST

Address: 713 E Austin Blvd, Nevada, MO 64772

Phone: (702) 293-4262

Email: info@titanpostdrivers.com

TITAN
POST DRIVERS