

Assembly Video: <https://youtu.be/AzcN2S43ub0>

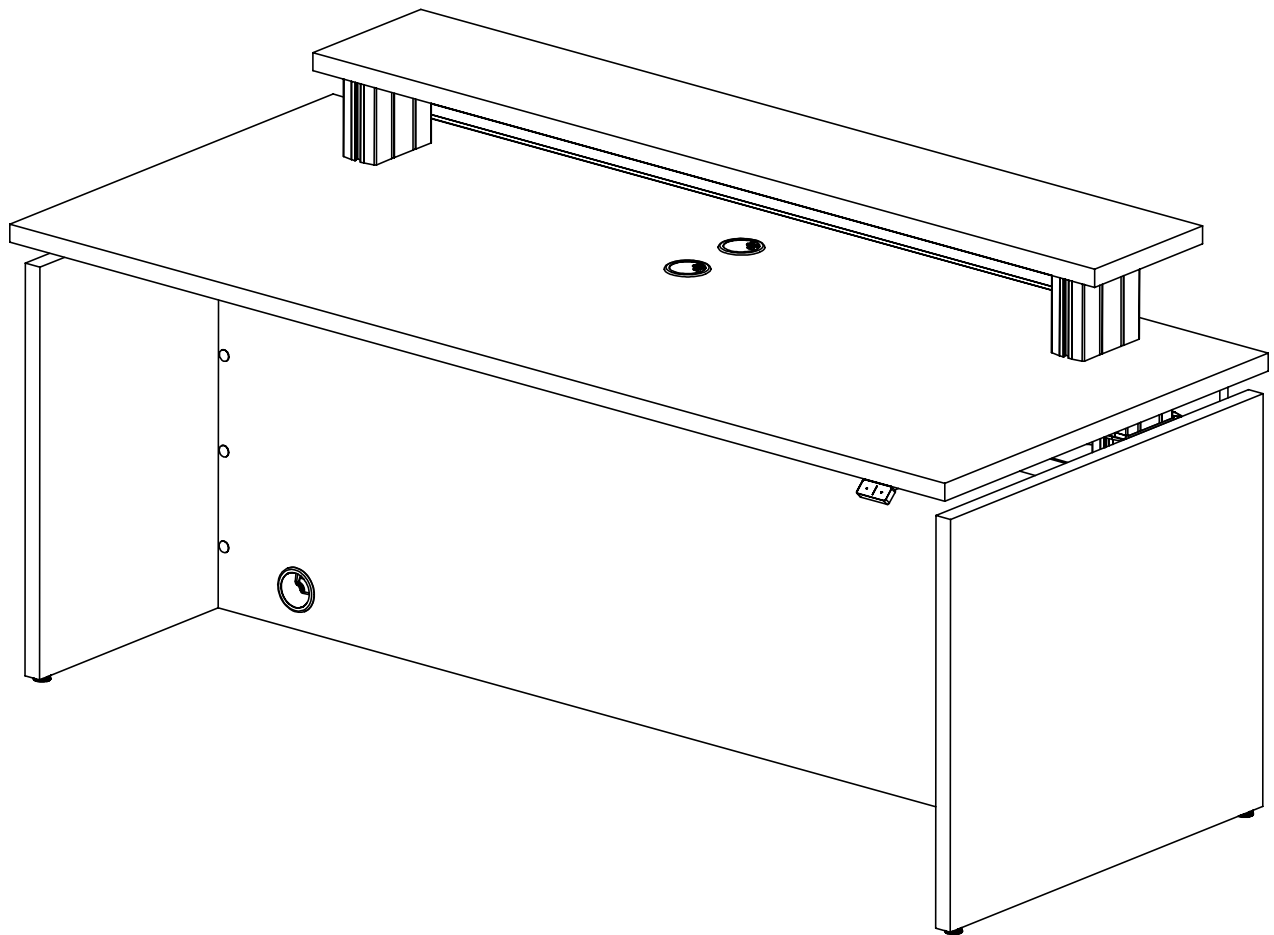

NewHeights™ Presidente Reception Assembly Instructions
Warranty: raproducts.com/warranty



READ ALL INSTRUCTIONS BEFORE USING THIS PRODUCT.



**USE THIS PRODUCT ONLY AS INSTRUCTED.
FAILURE TO COMPLY WITH ALL INSTRUCTIONS AND WARNINGS
MAY RESULT IN SERIOUS PROPERTY DAMAGE OR BODILY INJURY.**

Basic Safety Instructions

- 1. Intended Use.** This Product is exclusively designed for use as indoor office furniture in compliance with all instructions and safety warnings in the user manual. Any different use, or use extending beyond the intended use, may result in property damage or bodily injury and is prohibited. This Product should not be used, operated or maintained with additional components not authorized by RightAngle Products.

BY USING THIS PRODUCT OR ANY FEATURE OF THIS PRODUCT, YOU AGREE TO COMPLY WITH ALL PRODUCT TERMS AND POLICIES, INCLUDING WITHOUT LIMITATION ANY SAFETY WARNINGS AND INSTRUCTIONS, PROVIDED BY RIGHTANGLE PRODUCTS AND ITS AFFILIATES. RIGHTANGLE PRODUCTS SHALL ASSUME NO LIABILITY FOR ANY DAMAGE OR INJURY CAUSED BY USE OF THE PRODUCT A) IN VIOLATION OF ANY SAFETY WARNINGS OR INSTRUCTIONS; B) NOT AUTHORIZED BY RIGHTANGLE PRODUCTS; OR C) BY EVENTS BEYOND RIGHTANGLE PRODUCT'S CONTROL.



**DO NOT SIT, STAND OR CRAWL ON OR UNDER THE PRODUCT.
MAKE SURE NO OBSTACLES ARE IN THE PRODUCT'S PATH.
MAKE SURE ALL CORDS ARE LONG ENOUGH TO ACCOMMODATE ANY CHANGE IN HEIGHT.
DO NOT USE ATTACHMENTS NOT RECOMMENDED BY THE MANUFACTURER.**

- 2. Electrical Height Adjustment.** The height of this Product may be adjusted electronically. Contact with electrical voltage may cause serious injury and death. Only use the Product in compliance with these instructions. This Product should not be used in environments with high levels of humidity or moisture.



**KEEP CORDS AND ELECTRICAL COMPONENTS AWAY FROM HEAT AND LIQUIDS.
DO NOT OPEN ANY OF THE COMPONENTS: LEGS, CONTROL BOX, OR KEYPAD.
DO NOT USE WITH A DAMAGED PLUG OR CORD.
DO NOT INSERT ANYTHING INTO ANY SEAM OR OPENING.**

- 3. Setup and Use.** This Product should only be used and operated in good condition. When in use, no one should sit, stand or crawl on or under the Product. There is a danger of crushing, shearing, injury or damage. Keep the entire range of motion of the Product clear of all obstacles. Devices and object on the Product can tip over, fall or be crushed by the Product.



**KEEP HANDS AND FINGERS CLEAR.
KEEP ALL OBSTACLES CLEAR OF THE PRODUCT'S PATH.**

- 4. Users.** This Product is not intended for use with children, individuals with restricted physical, sensory or mental capabilities, or individuals who lack experience or knowledge, unless they are supervised by a person who is responsible for their safety or they have received instructions from a person who is responsible for their safety concerning how the Product must be used. Children should be closely supervised to ensure that they do not play with the Product and its height adjustment mechanism to avoid risk of physical injury or electric shock.



KEEP CHILDREN AWAY FROM THE PRODUCT, ITS CONTROL UNITS, AND KEYPADS.

Tools Required for Assembly

- A. Power Driver with Adjustable Torque
- B. #2 Phillips Head Driver Bit
- C. #2 Square Head Drive Bit
- D. 3/16" Hex Head Driver Bit or Allen Wrench
- E. 3/16" Allen Wrench

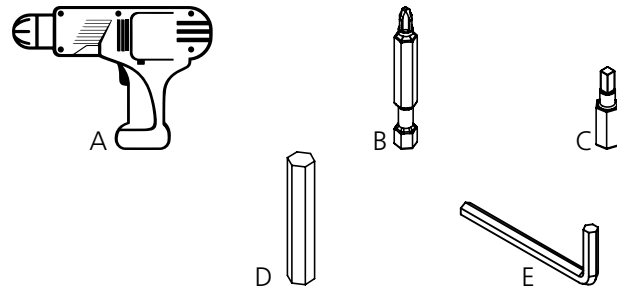

Hardware Included for Assembly (may have extra)

- F. 3/8-16 x 1" Black Adjustable Glide x4
- G. SlimFix Bolt for 5mm Hole Zinc x24
- H. 5/16"-18x3/8" Button Socket Cap Screw x4
- I. Peel and Stick Screw Cover Caps Black x8
- J. 10 X 5/8" Round Washer Head Drive Screw x45
- K. 8 x 3/4" Pan Head Recex Drive Screw x4
- L. Cable Clamp 3/16 Black x1
- M. 5/16-18- Weld Nut x2
- N. 10-32 x 6" Ph Pan Hd Machine Screw x4
- O. Grommet Insert x4

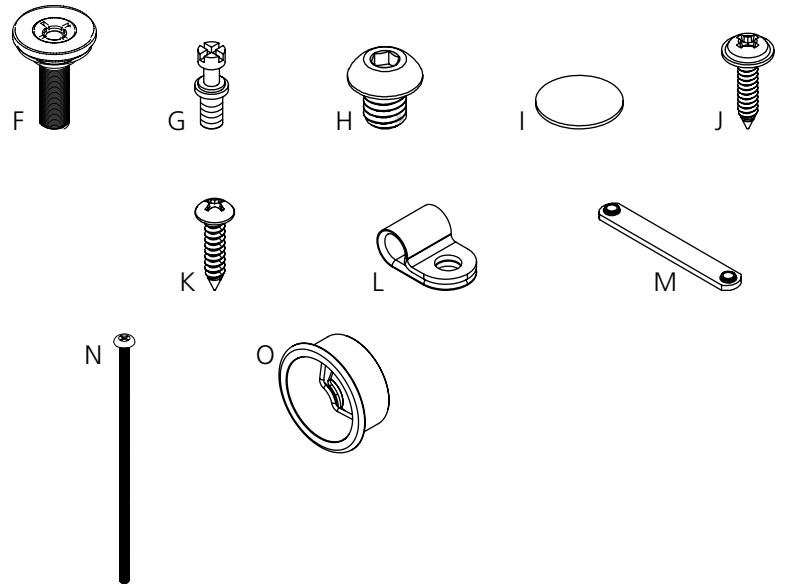

Parts

- P. NXT 2 Leg Base - Two Motor Control Box Including GyroSense x1
- Q1. Two Button Up/Down Switch x1
- Q2. Four Button Programmable Up/Down Switch x1
Optional - If you have a programmable switch, please refer to the installation instructions included with the switch.
- R. U-Channel x1
- S. Front Brackets x2
- T. Support Covers x2

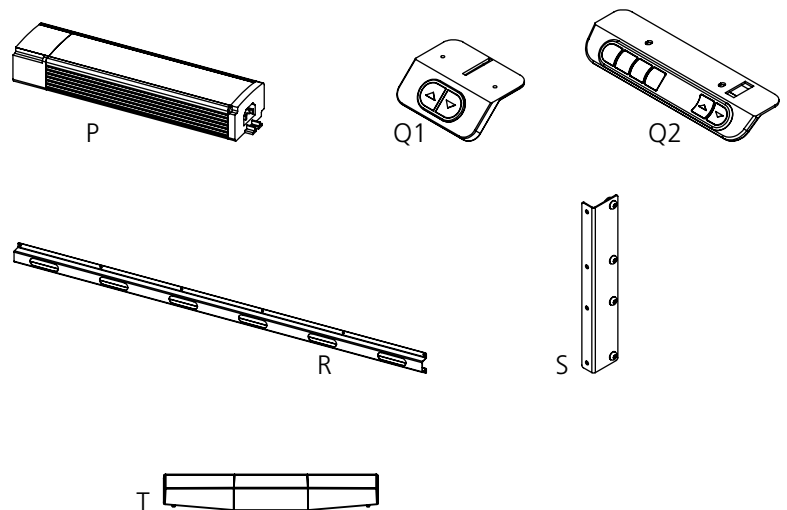

Step 1

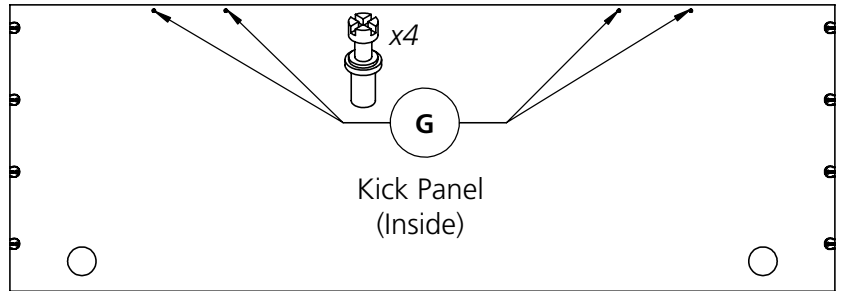
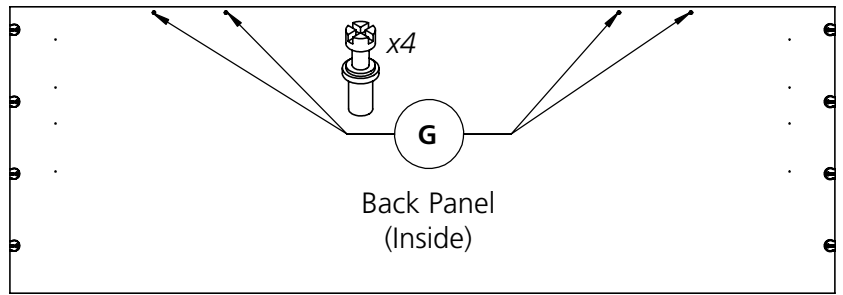
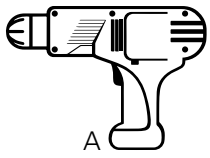

Step 2

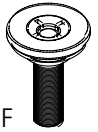
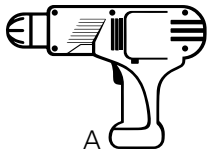

Install levelers

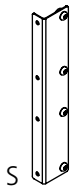
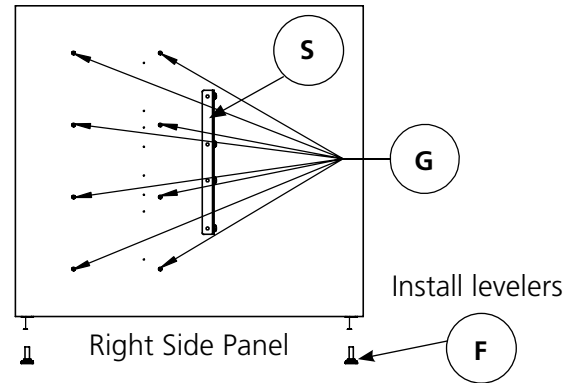
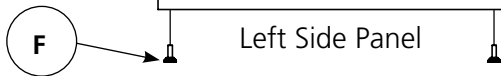

Step 3

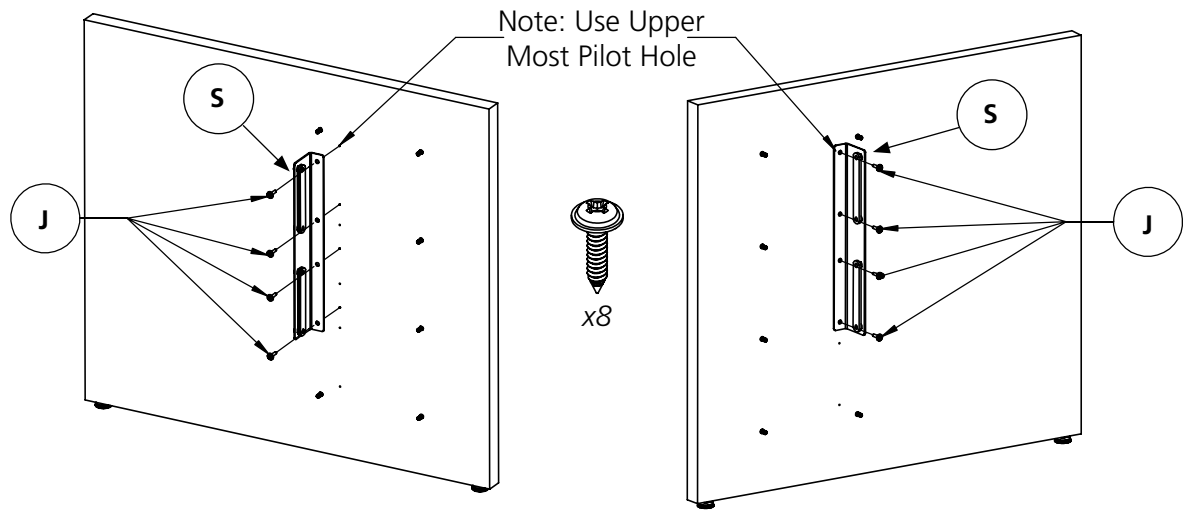
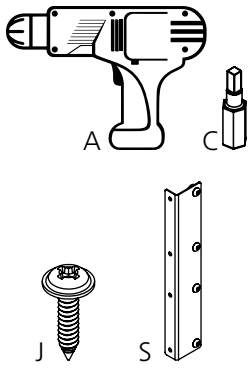

Step 4

- Tighten cams to join side panels to back panel.

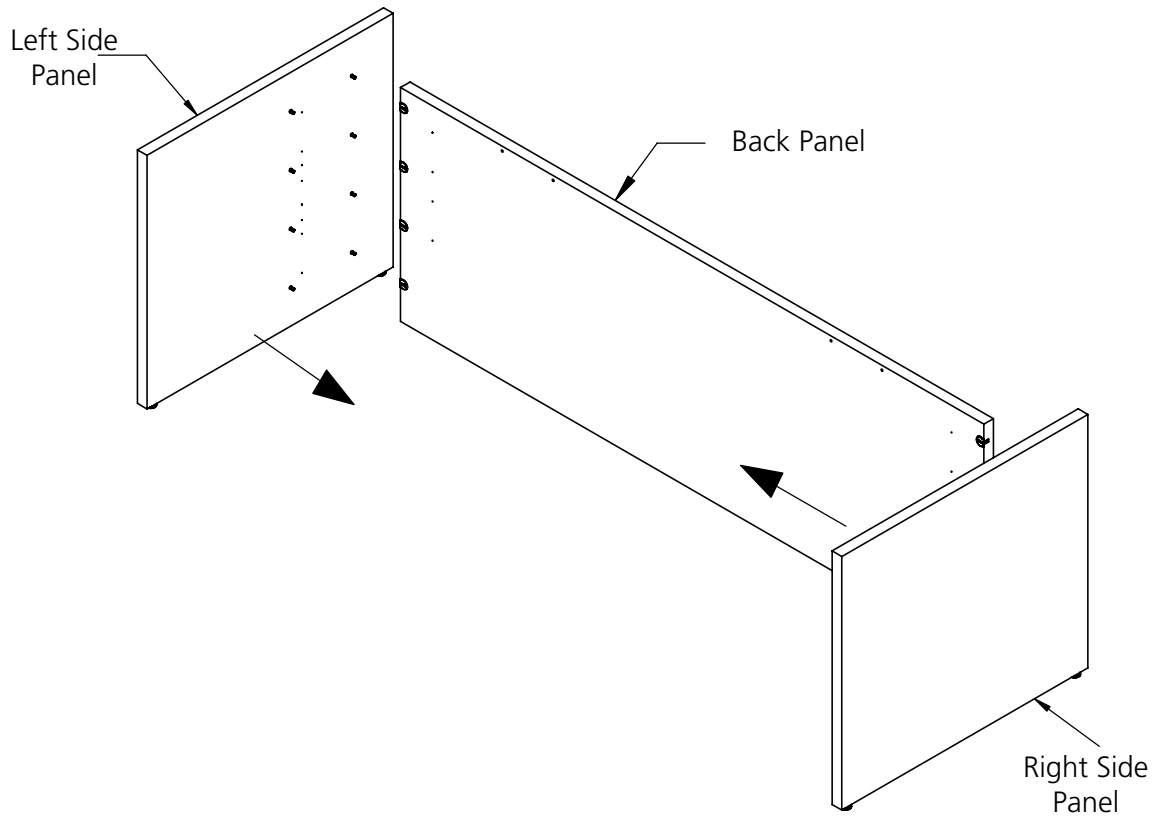

Step 5

- Slide the weld nuts on the side brackets into the grooves at the front of the columns.

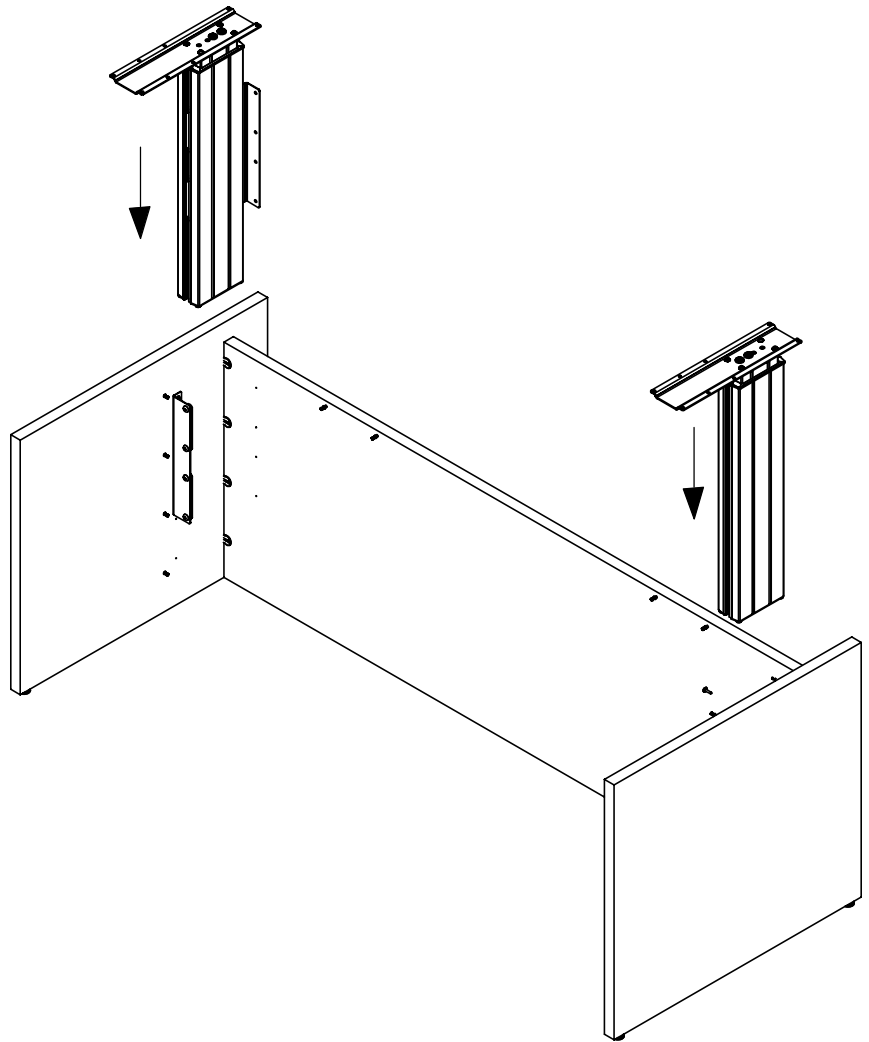

Step 6

- Drive the wood screws into the pilot holes. Then tighten the machine screws. Left hand shown. Right hand same.

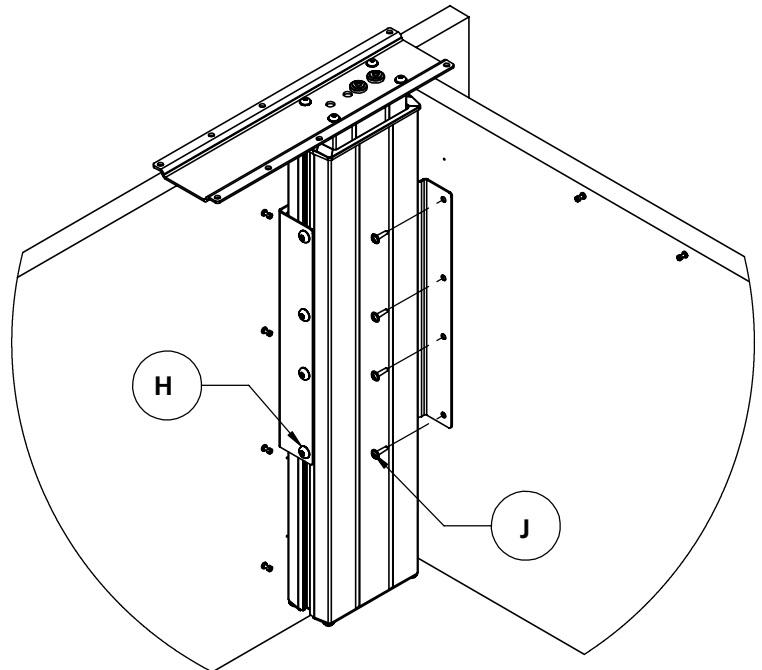
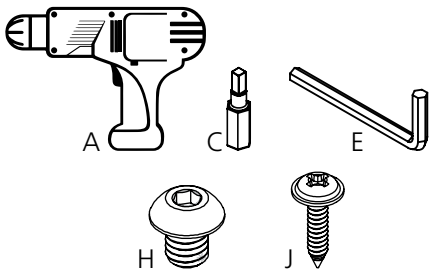

Step 7

- Tighten cam locks through holes in kick panel. Reversed Direction.

Counter Clockwise = Tighten
Clockwise = Loosen

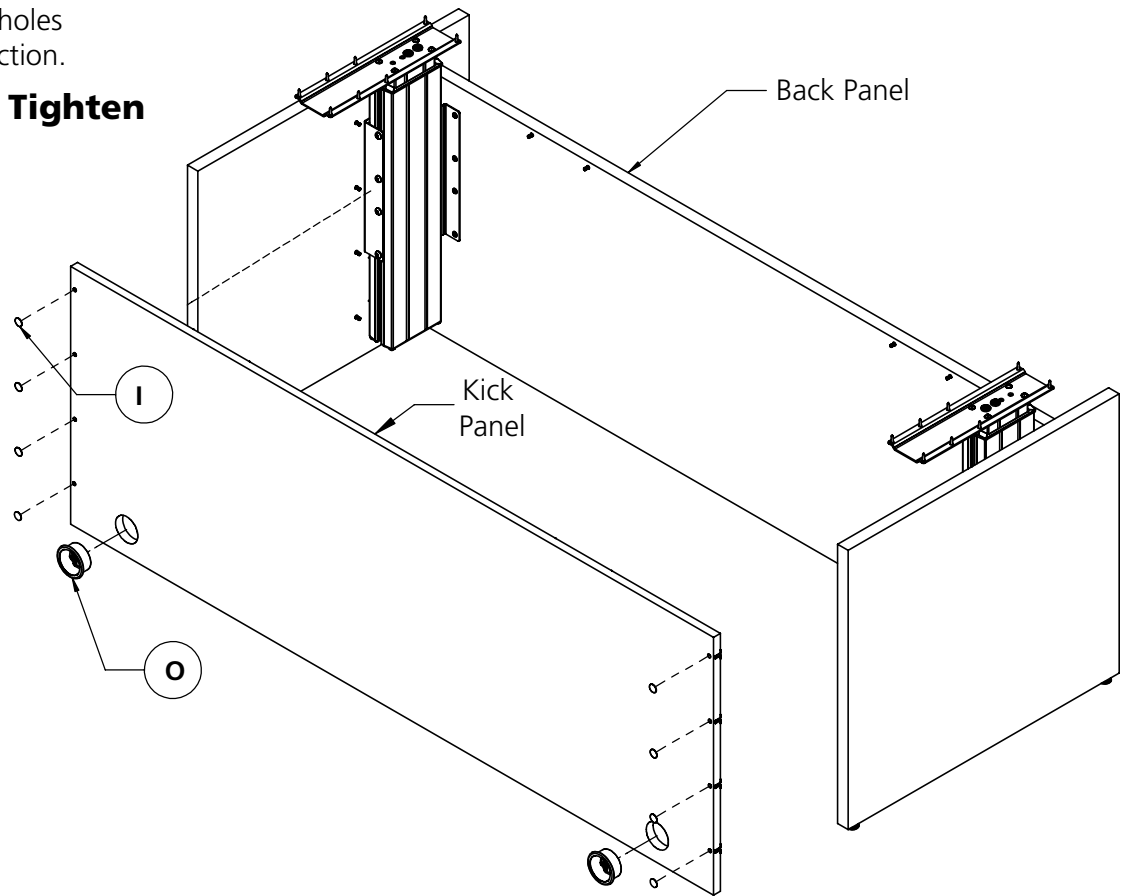
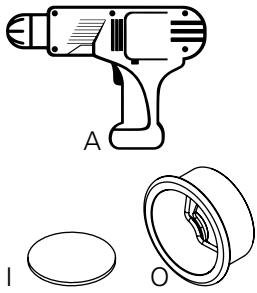

Step 8

- Slide the cross braces between the back panel and kick panel under the slim fix bolts.
- Raise up and engage the bolts into the cams. Tighten the cam locks.

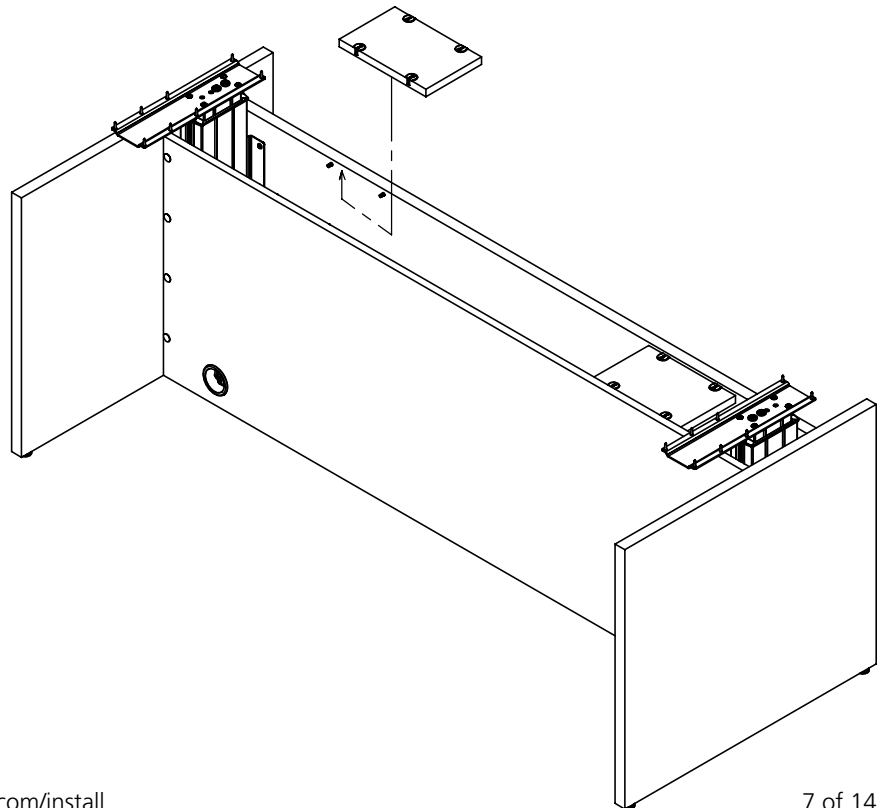

Step 9

Note: refer to modesty panel instruction #53901

- Install switch, U-Channel and control box on the bottom of the worksurface.
- Note: Install modesty panel (**optional**). Refer to modesty panel instruction #53901.

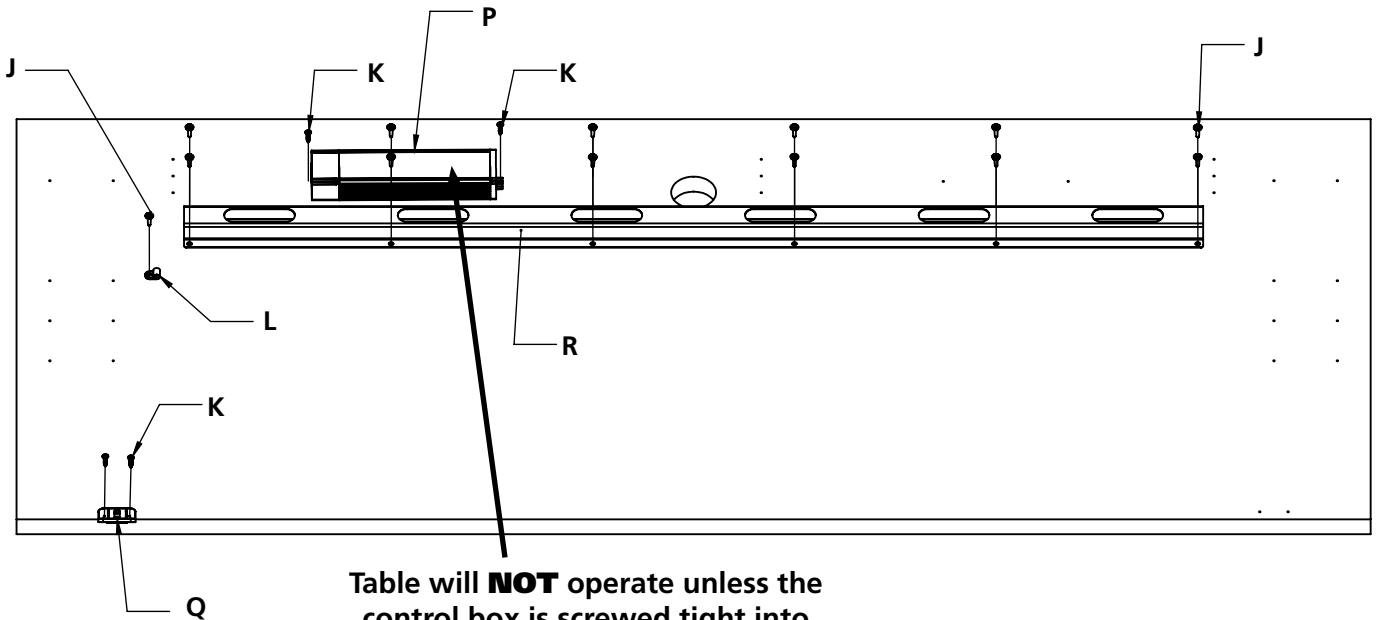
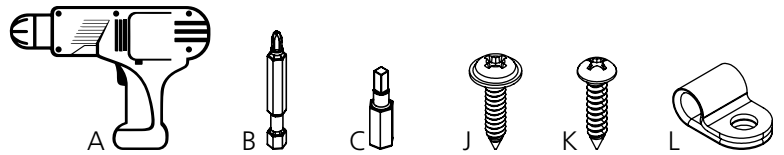
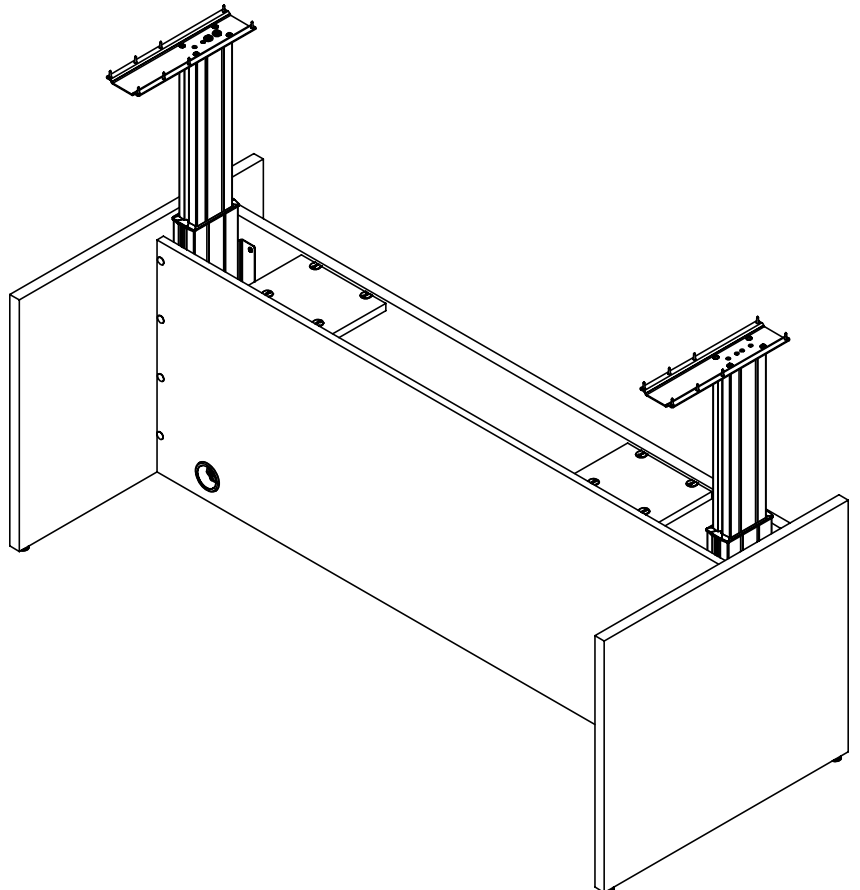
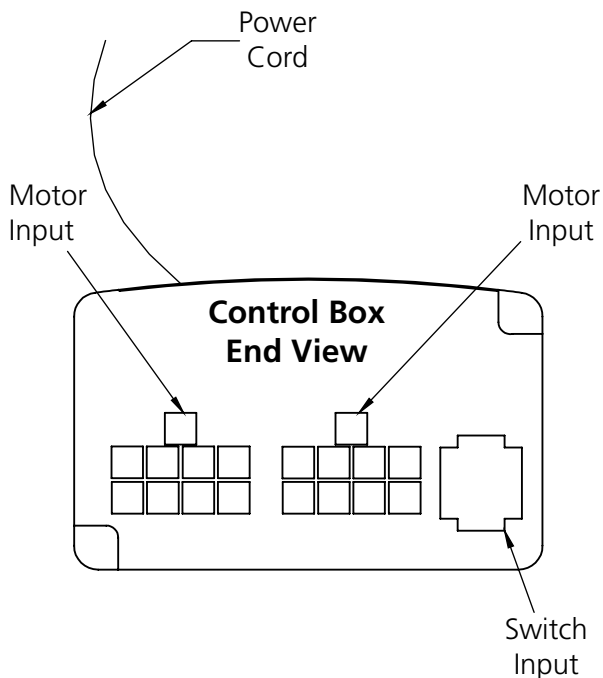

Table will **NOT** operate unless the control box is screwed tight into the table without any play.

Step 10

- Install control box **temporarily** connect switch, motor cables and power. Lower to lowest position and reset. Raise to highest position and disconnect all cables.



Step 11

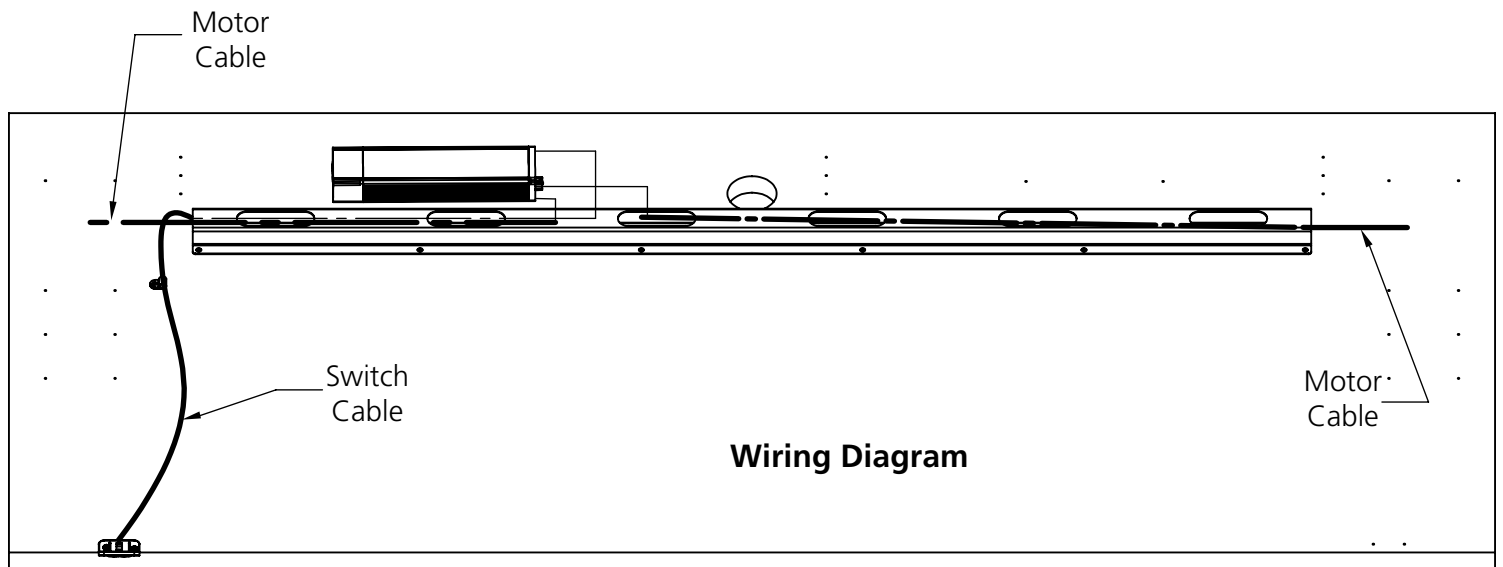

Step 12

- Attach worksurfaces support to worksurface and motor cables from control box.

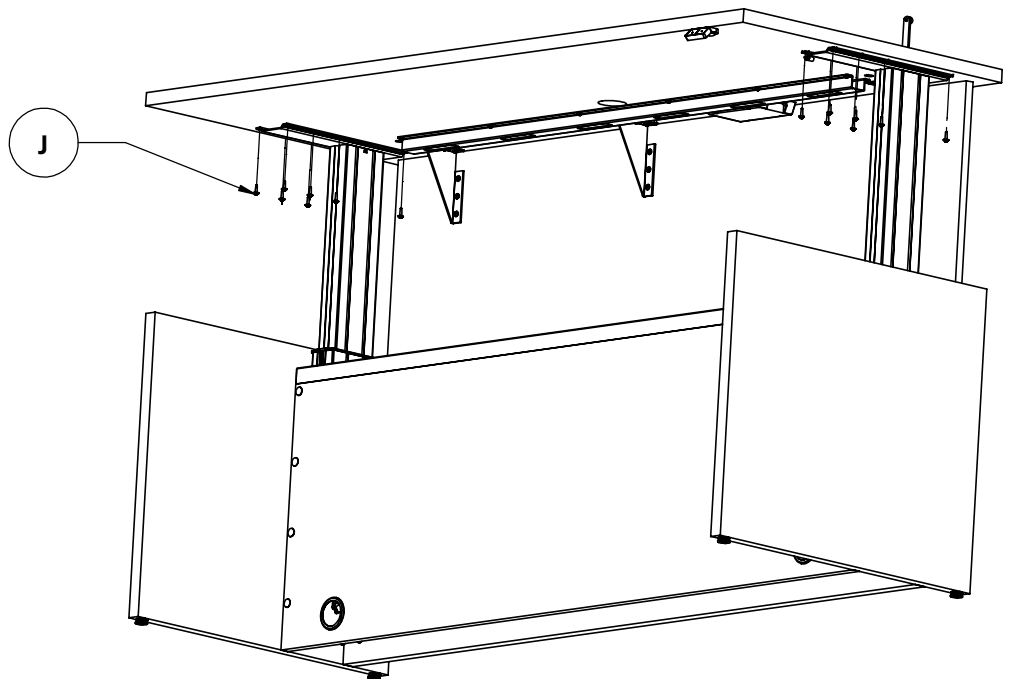
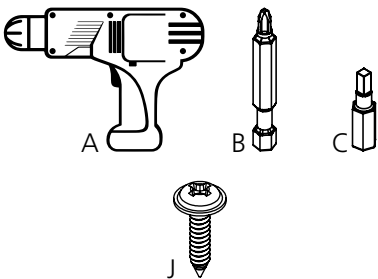

Step 13

- Loosely install weld nuts and bolts to back side of cross support, slide into short aluminum extrusions.

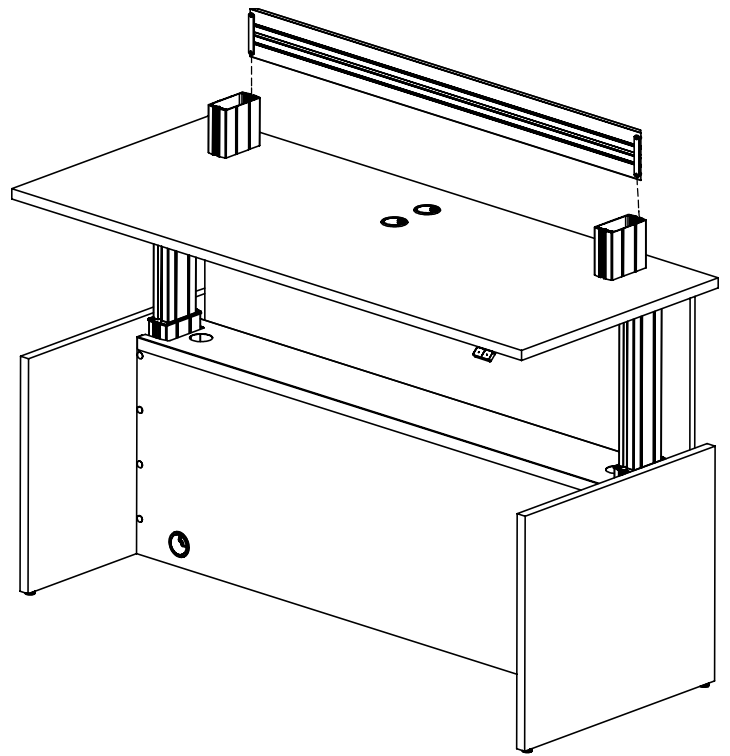
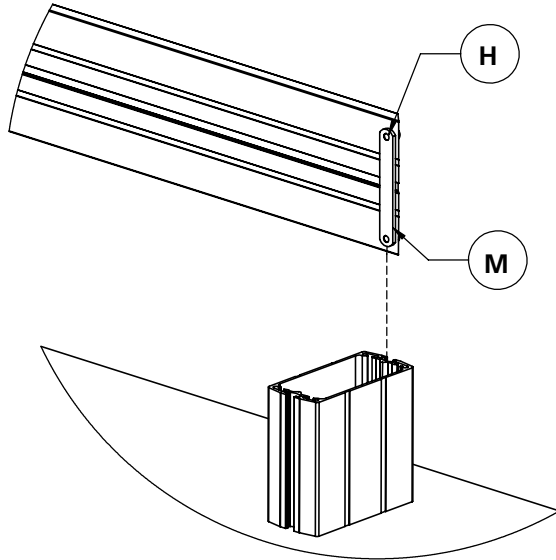
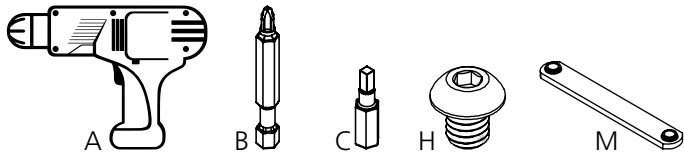

Step 14

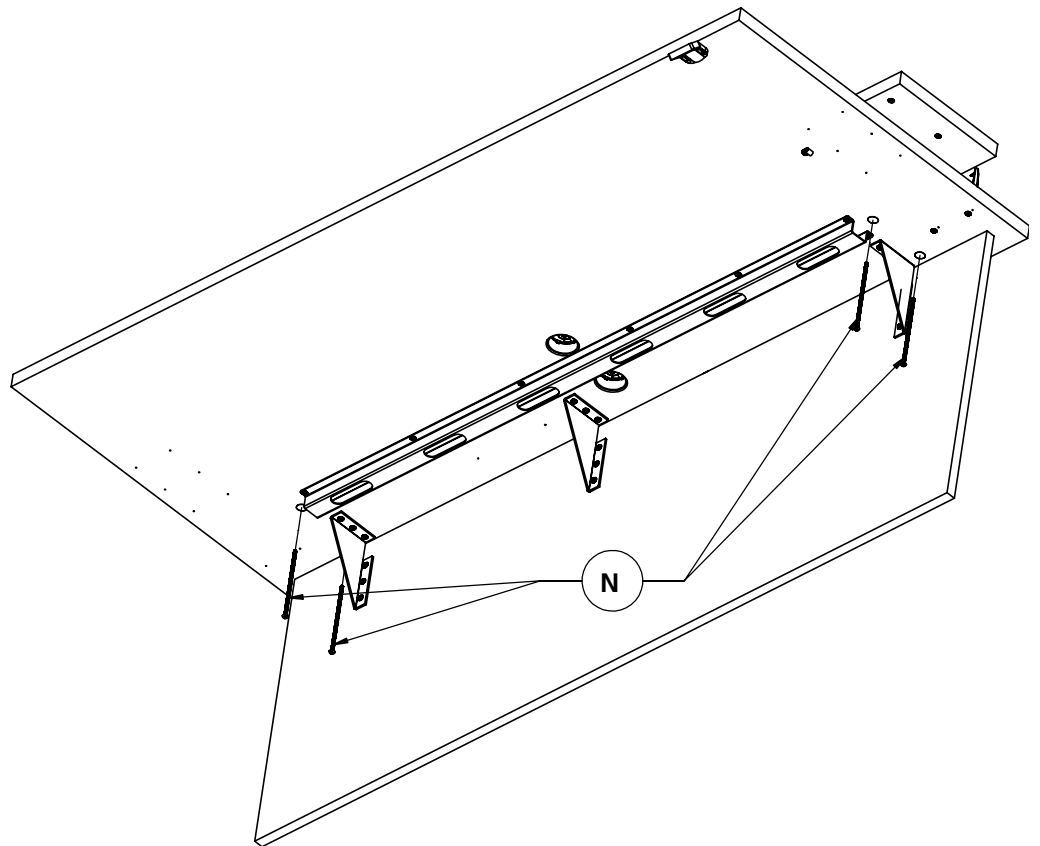
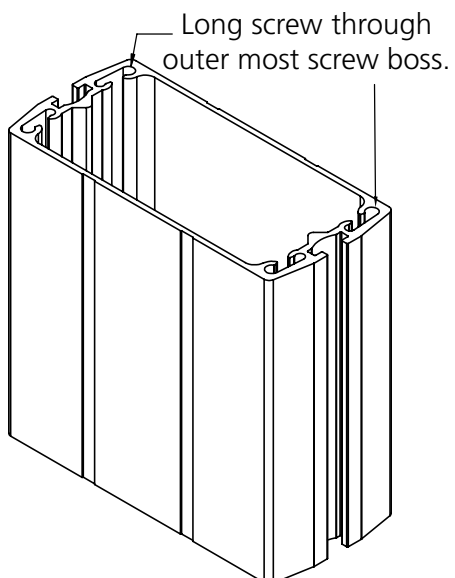
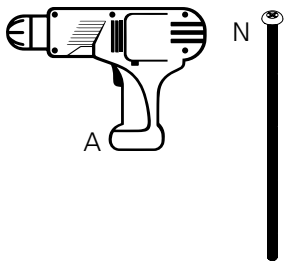

Step 15

- Do not tighten screws until all are installed. Once all screws are installed, tighten four cross support screws and four long screws.

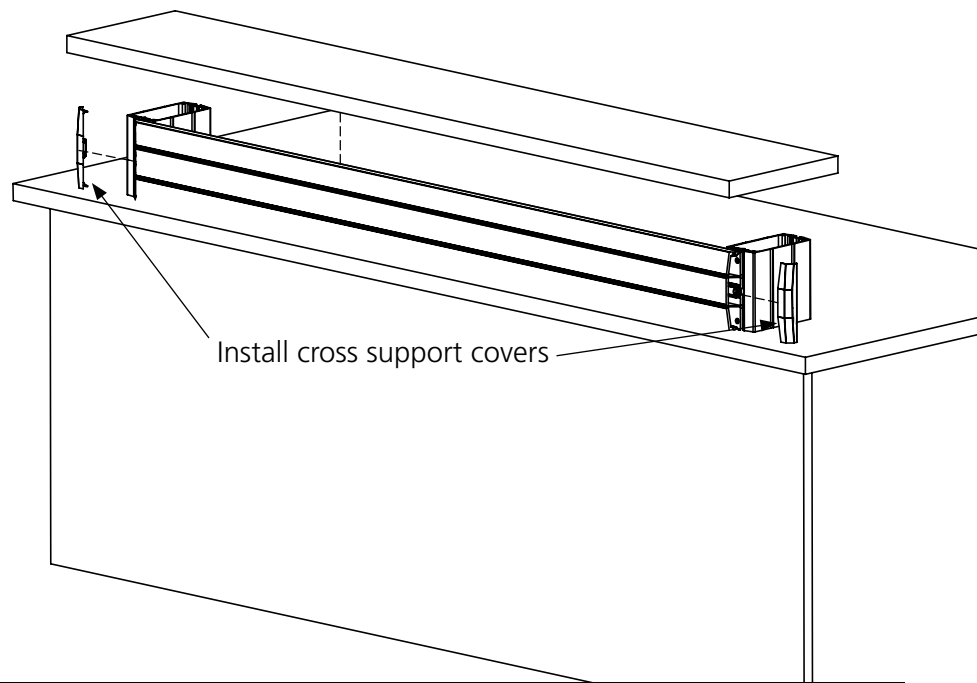
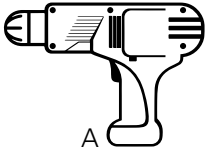

Step 16

- Install divider cover and worksurface grommet insert.

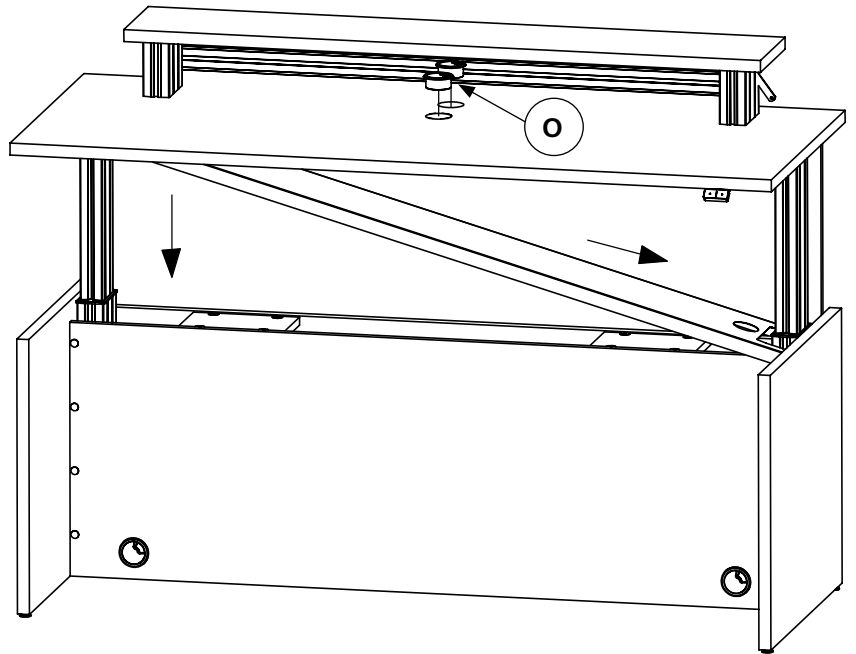
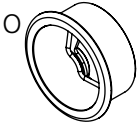

Step 17

- Lower table to lowest position to reset.

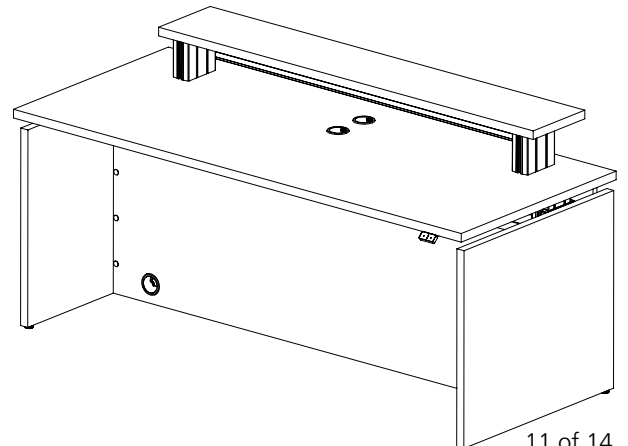

Note

If the leg assemblies are at uneven heights, it is usually caused by an improperly installed hex rod. Disassemble one of the leg assemblies from the worksurface and make sure both ends of the hex rod are properly engaged in the hex drives near the top of the leg assemblies.

Standard Switch Save for Reference

Start Up Procedure:



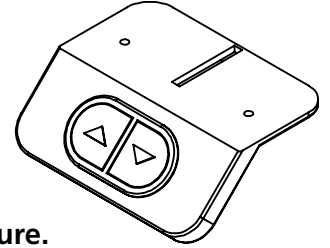









- Plug the power cord into a standard 110V receptacle. A power surge protector is recommended.
- Press the down arrow until the worksurface reaches its lowest position.
- The workstation is ready for use.
- **If the table is not functioning normally or has lost power, perform the reset procedure.**













Reset Procedure:

- Unplug the unit from the wall for 10 seconds.
- Clear all obstructions from the travel path of the desk.
- Plug the unit back in the wall.
- Press and hold the down arrow key until the table reaches its lowest position.

Add Container Stops:

- Move the table  to the upper or lower desired height.
- Rapidly press  4 times. You will hear a musical tone. 
- Rapidly press  2 times. A musical tone plays two times.  
 - To **add** the **upper** container stop press  A musical tone plays two times.  
 - To **add** the **lower** container stop press  A musical tone plays two times.  

Remove Container Stops:

- Move the table  to the upper or lower **preset** height.
- Rapidly press  4 times. You will hear a musical tone. 
- Rapidly press  2 times. A musical tone plays two times.  
 - To **delete** the **upper** container stop press  You will hear a musical tone. 
 - To **delete** the **lower** container stop press  You will hear a musical tone. 

Troubleshooting:

If you are having any problems with the operation, contact RightAngle Products at **800.298.4351** or **orders@raproducts.com**

Optional Programmable Switch (full instructions packaged with switch)

Start Up Procedure:

- Plug the power cord into a standard 110V receptacle. A power surge protector is recommended.
- Press the down arrow until the worksurface reaches its lowest position.
- The workstation is ready for use.
- **If the table is not functioning normally, or has lost power, perform the reset procedure.**

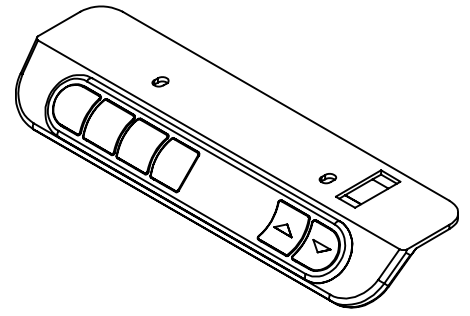

Reset Procedure:

- Unplug the unit from the wall for 10 seconds.
- Clear all obstructions from the travel path of the desk.
- Plug the unit back in the wall.
- Press and hold the down arrow key until the table reaches its lowest position

See Packaged Instructions for Programmable Options

Mechanical Reset Mode

If the table is unresponsive, uneven, or not functioning properly, perform a manual reset.











User settings are not reset in this process.

There are three methods to reset a workstation:

Reset Method A















1. Clear all obstructions from the travel path of the workstation
2. Disconnect the power to the control box for 30 seconds.
3. Reconnect the power
4. Press and hold the  until the workstation has reached its lowest possible position.

Reset Method B (4 button programmable switch required)

1. Clear all obstructions from the travel path of the workstation
2. Quickly press  +  +  +  to enter the menu mode.
3.  is displayed and you will hear a musical tone. 
4. Press the   to navigate the menu.
5. Navigate to the  display
6. Press the  button to enter or accept
7. Press and hold the  until the workstation has reached its lowest possible position.

The workstation is now ready to operate

Reset Method C - 2 Button Switch

1. Clear all obstructions from the travel path of the workstation
2. Quickly press  +  +  +  to enter the menu mode.
3. You will hear a musical tone. 
4. Press  +  +  + 
5. You will reach the limit adjustment menu and hear four musical tones.    
6. Press and hold the  until the workstation has reached its lowest possible position.

The reference is re-calibrated, the table should be leveled and the height indication should be correct.