

DETAIL B  
SCALE 4 : 1

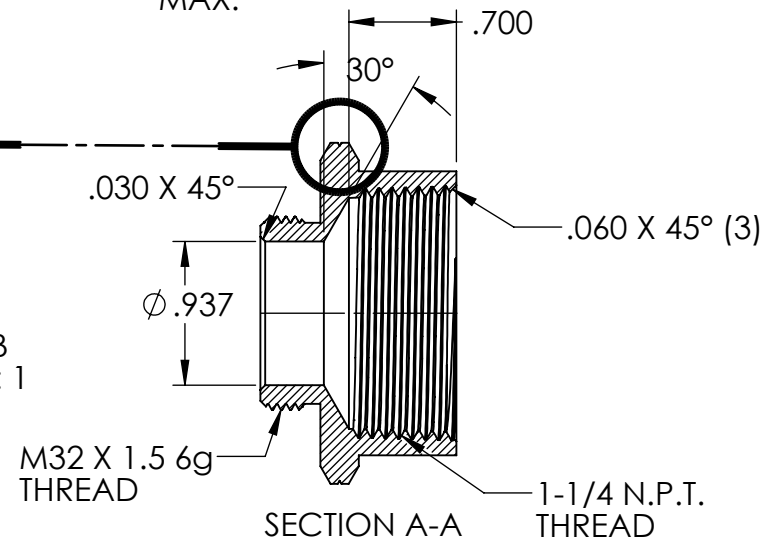
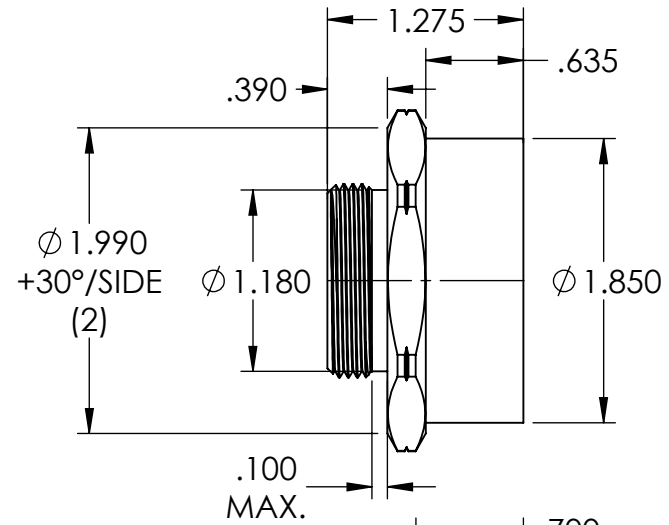

NOTES:

- 1.) PART A IS PLATED ELECTROLESS NICKEL .0001 MIN-.0003 MAX.
- 2.) PART UP IS UNPLATED
- 3.) BREAK ALL SHARP CORNERS
- 4.) REF. BAR-29 (2" HEX SOLID)

REV.	DATE	CHANGE	UNLESS OTHERWISE SPECIFIED:	NAME	DATE	<b>REMKE</b> <b>REMKE INDUSTRIES</b> 310 CHADDICK DR, WHEELING, IL. 60090	
A	10/9/02	DRAWING RELEASED C.V.	DIMENSIONS ARE IN INCHES TOLERANCES: FRACTIONAL $\pm 1/64$ ANGULAR: MACH $\pm 1^\circ$ BEND $\pm 1^\circ$ ONE PLACE DECIMAL $\pm .015$ TWO PLACE DECIMAL $\pm .010$ THREE PLACE DECIMAL $\pm .005$	DRAWN JCN	7/15	TITLE: <b>ADAPTER</b>	
B	2/10/03	60° PROFILE WAS 70° & UNDERCUT $\varnothing$ 1.180 WAS $\varnothing$ 1.175	INTERPRET GEOMETRIC TOLERANCING PER:	CHECKED		SIZE <b>A</b>	DWG. NO. <b>RAM-32M125F-A</b>
C	7/16/15	REDRAWN	MATERIAL <b>ALUMINUM</b>	ENG APPR.		SCALE: 0.8:1	SHEET 1 OF 1
			FINISH <b>NICKEL PLATED</b>	MFG APPR.			
			DO NOT SCALE DRAWING	Q.A.			
				<b>PROPRIETARY AND CONFIDENTIAL</b> THE INFORMATION CONTAINED IN THIS DRAWING IS THE SOLE PROPERTY OF REMKE INDUSTRIES. ANY REPRODUCTION IN PART OR AS A WHOLE WITHOUT THE WRITTEN PERMISSION OF REMKE INDUSTRIES IS PROHIBITED.			

5

↑

4

3

2

1