

SECTION A-A

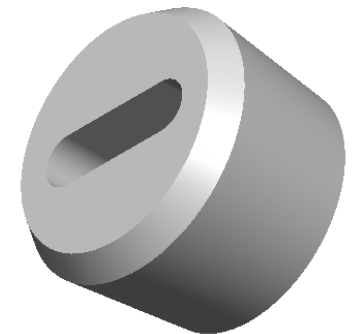
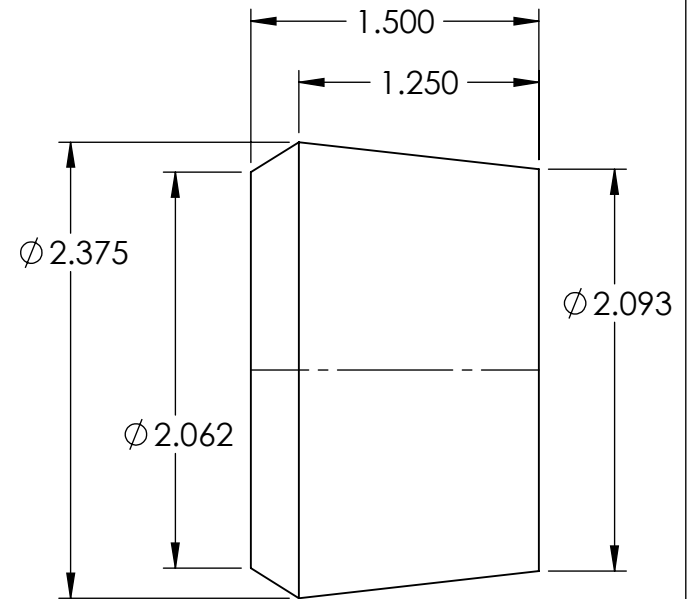

NOTES:

1. FLASH TO BE HELD TO A MINIMUM AND MAY NOT WEB ACROSS HOLES.
2. I.D. AND O.D. CONCENTRICITY .020.
3. ALL OTHER DIMENSIONS $\pm .015$.
4. MATERIAL: BLACK NEOPRENE 50-60 DUROMETER

REV.	DATE	CHANGE	UNLESS OTHERWISE SPECIFIED:	NAME	DATE	REMKE INDUSTRIES 310 CHADDICK DR, WHEELING, IL. 60090	
A	11/19/03	DRAWING RELEASED	DIMENSIONS ARE IN INCHES	DRAWN	JCN	9/15	TITLE: BUSHING
B	9/6/15	REDRAWN	TOLERANCES: FRACTIONAL $\pm 1/64$ ANGULAR: MACH $\pm 1^\circ$ BEND $\pm 1^\circ$ ONE PLACE DECIMAL $\pm .015$ TWO PLACE DECIMAL $\pm .010$ THREE PLACE DECIMAL $\pm .005$	CHECKED			
			INTERPRET GEOMETRIC TOLERANCING PER:	ENG APPR.			SIZE A DWG. NO. SBF-6013
			MATERIAL SEE NOTE	MFG APPR.			
			FINISH	Q.A.			SCALE: 2:1 SHEET 1 OF 1
			DO NOT SCALE DRAWING	PROPRIETARY AND CONFIDENTIAL THE INFORMATION CONTAINED IN THIS DRAWING IS THE SOLE PROPERTY OF REMKE INDUSTRIES. ANY REPRODUCTION IN PART OR AS A WHOLE WITHOUT THE WRITTEN PERMISSION OF REMKE INDUSTRIES IS PROHIBITED.			

5

↑

4

3

2

1