

REV	ECN NO.	CHANGE CONTENT	SIGNATURE	DATE
A1		FIRST ISSUED		

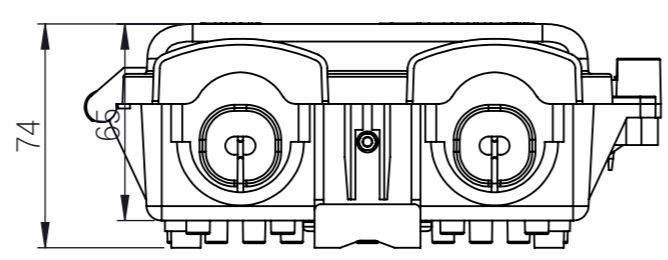
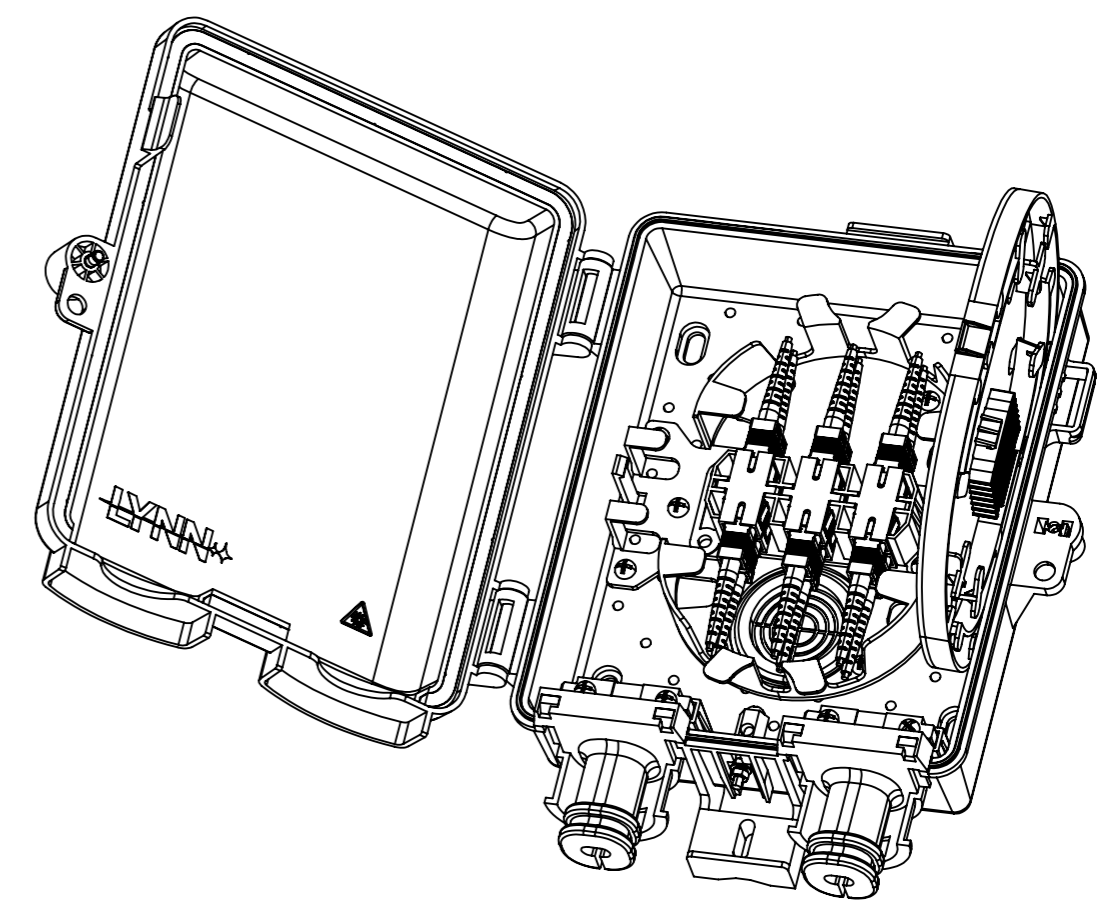
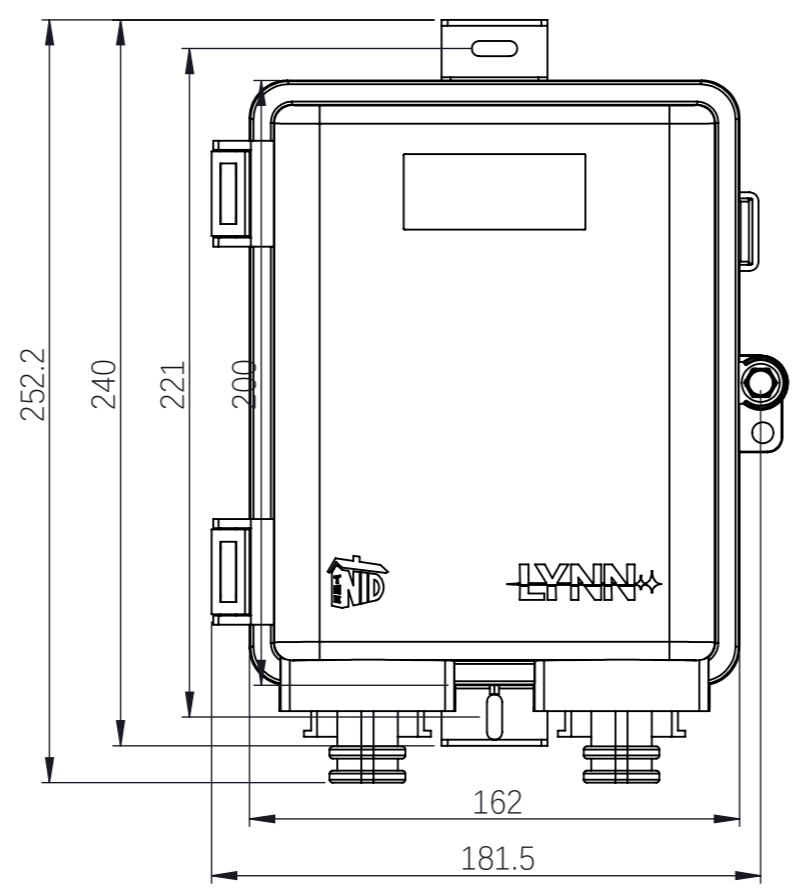
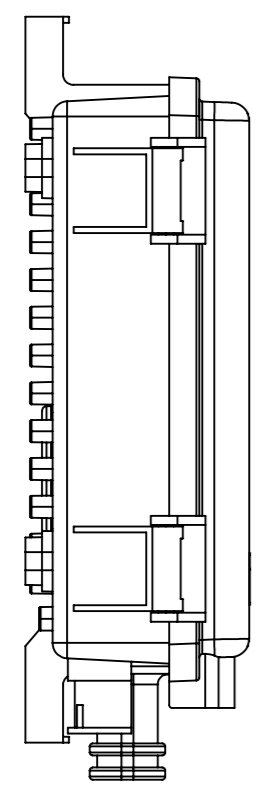

NOTE:
1. MATERIAL: PC+ABS;

	SIGNATURE	DATE	LYNN			
DRAWN	T. Hodson	2024/7/4	MAT'L		PRODUCT NO.	FPP-TN-Z-D2
CHK'D	J. Farrell	2024/7/4	UNITS	mm	PRODUCT NAME	FPP-TN-Z-D2-00000 BOX
PROCESS		2024/7/4	SCALE		DRAWING NO.	FPP-TN-Z-D2
APPV'D	C. Hoskins	2024/7/4	TYPE OF PROJECTION			SHEET 1 OF 1
					REV	A1