

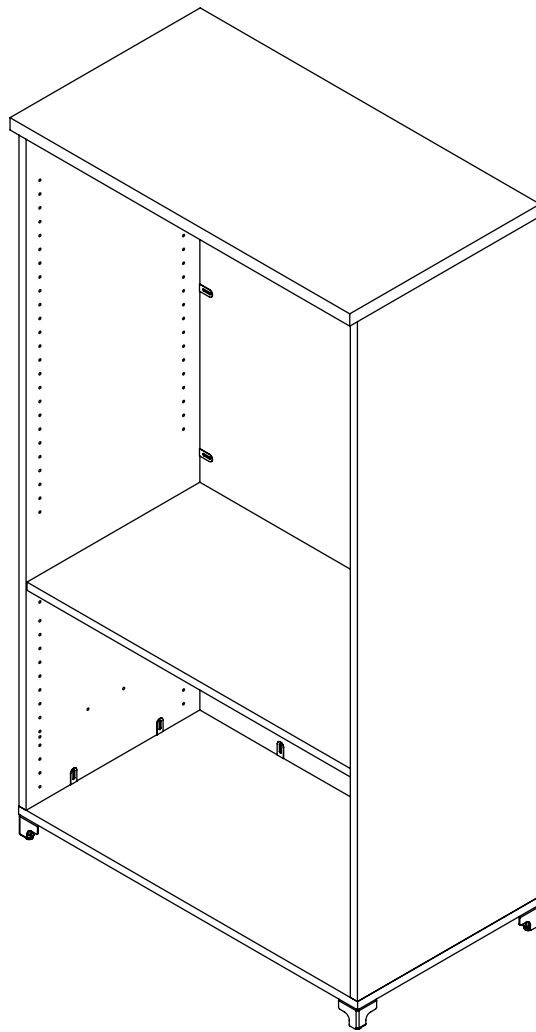

Tevita Casegoods Vertical Storage Assembly Instructions



Warranty: raproducts.com/resources/warranty

Tools Required for Assembly

- A. Power Driver with Adjustable Torque
- B. #2 Square Head Driver Bit

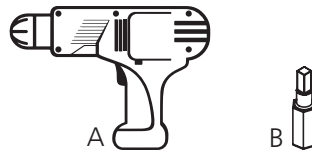

Hardware and Tools Included for Assembly (may have extra)

- C. 4mm Ball End Screwdriver
- D. 5/8" Washer Head Wood Screw x12

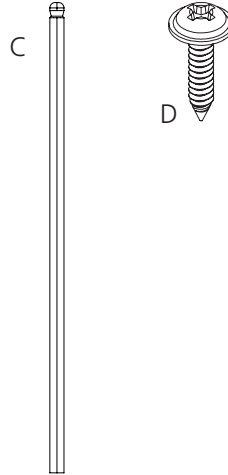

Parts

- E. Feet x4
- F. Bottom Panel x1
- G. Top Panel x1
- H. Right Panel x1
- I. Left Panel x1
- J. Back Panel x1
- K. Shelf Panel x1

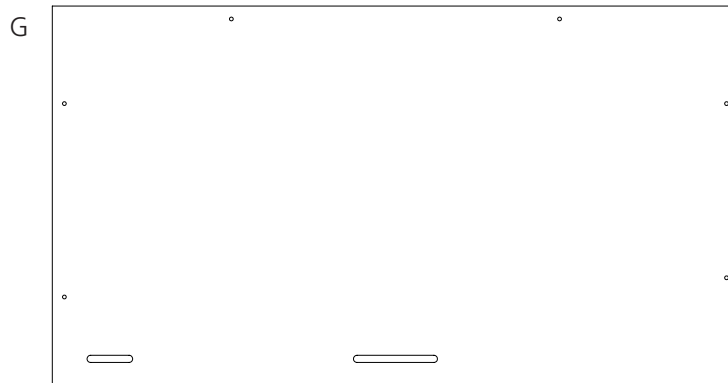
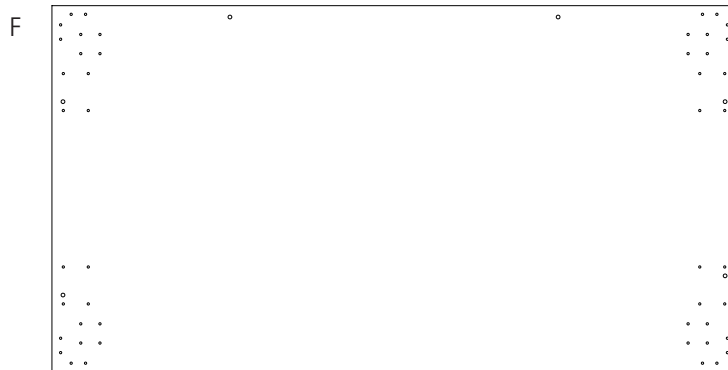
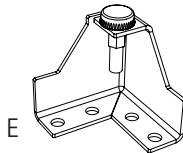

Parts (continued)

- H. Right Panel x1
- I. Left Panel x1
- J. Back Panel x1
- K. Shelf Panel x1

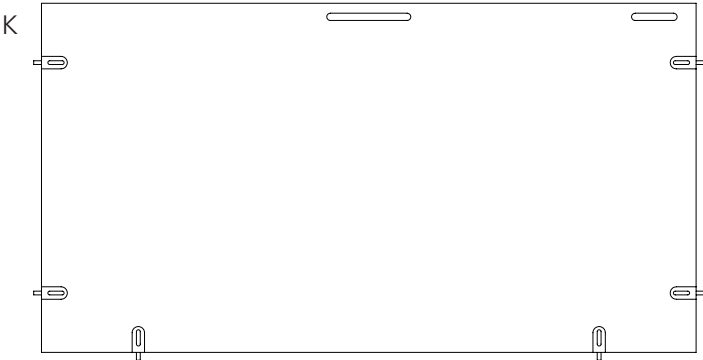
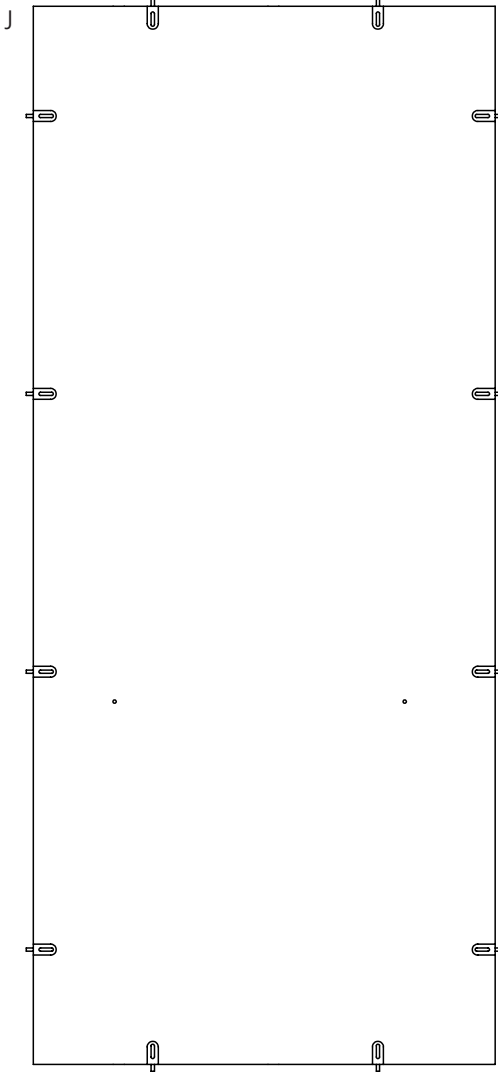
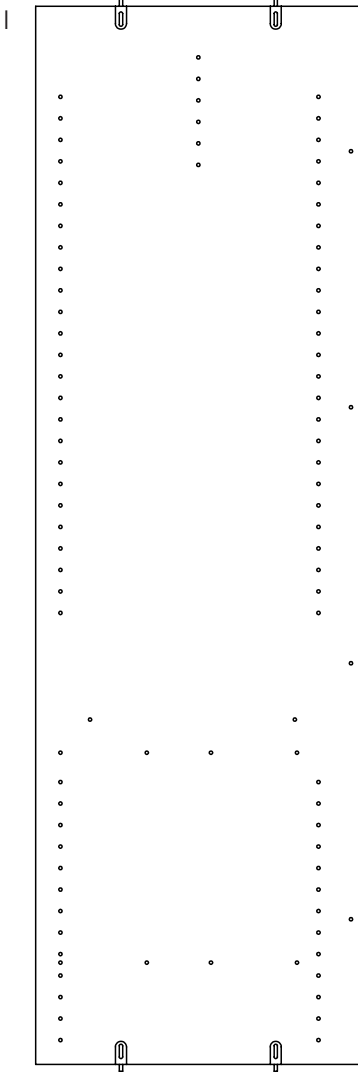
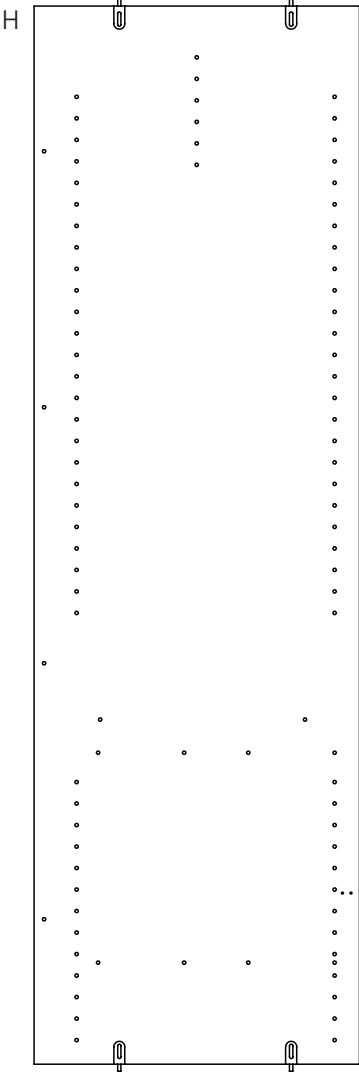

Step 1

- Gently place the bottom panel (F) onto a flat, protected surface with the pre-drilled pilot holes facing upwards.
- Align four feet (E) with the pre-drilled pilot holes on corners of the panel.
- Secure the feet to the bottom panel using four washer head wood screws (D) per foot.

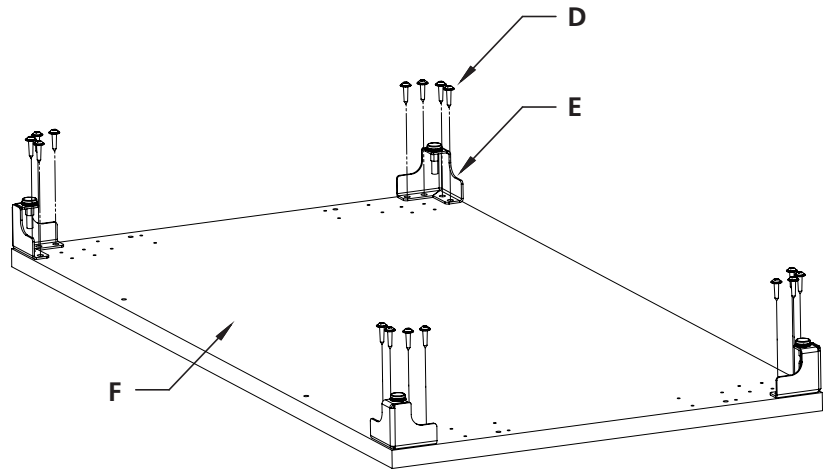
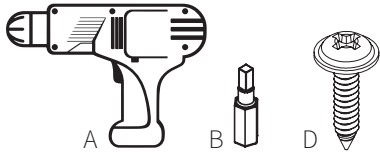

Step 2

- Gently place the right panel (H) onto a flat, protected surface with the pre-drill pilot holes facing upwards.
- Take the bottom panel (F) and align the pre-drilled pilot holes with the cabineo connectors on the right panel (H).
- Using the 4mm ball end screwdriver (C), screw the cabineo connectors to secure the panels together. See Figure A below to see how to use the 4mm ball end screwdriver (C).

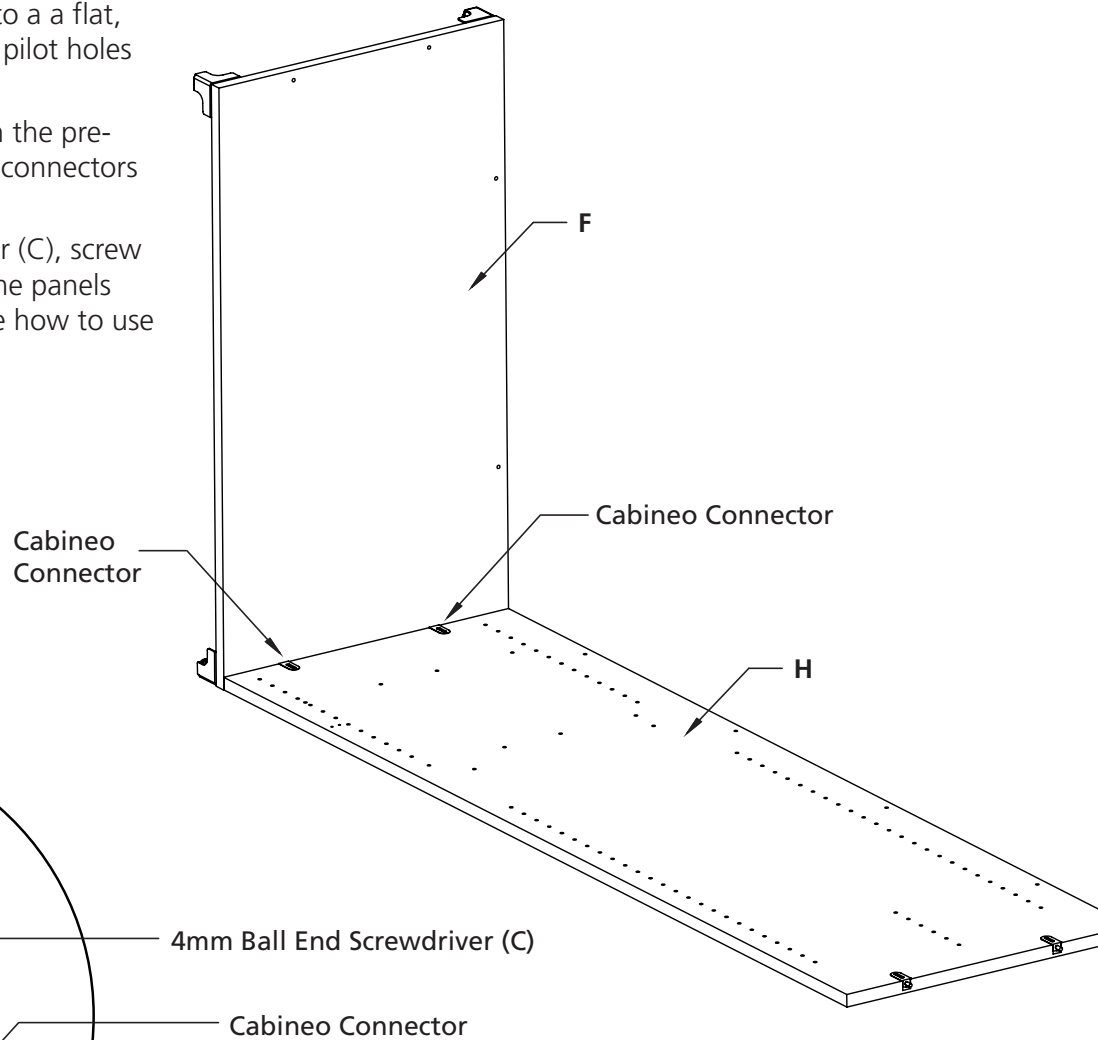
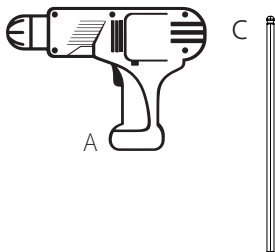
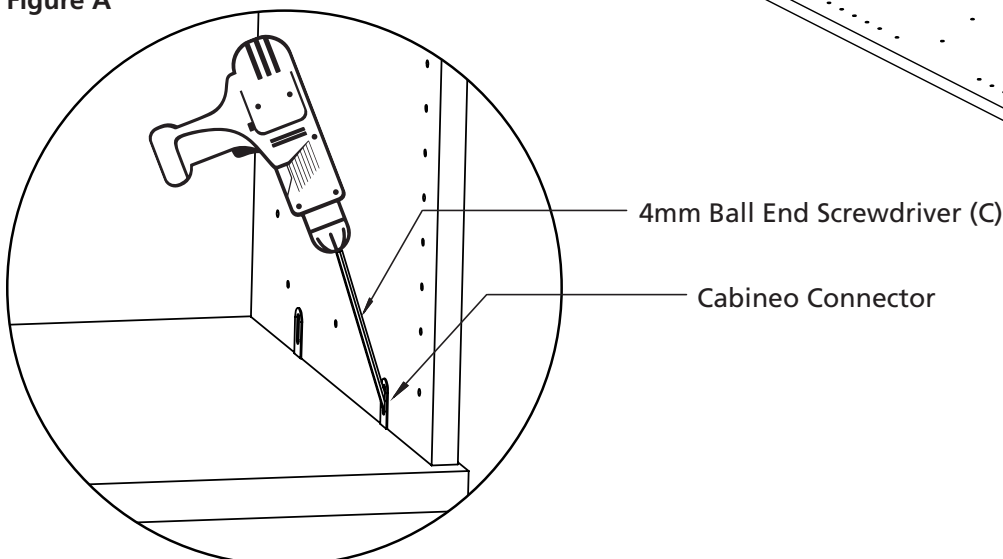
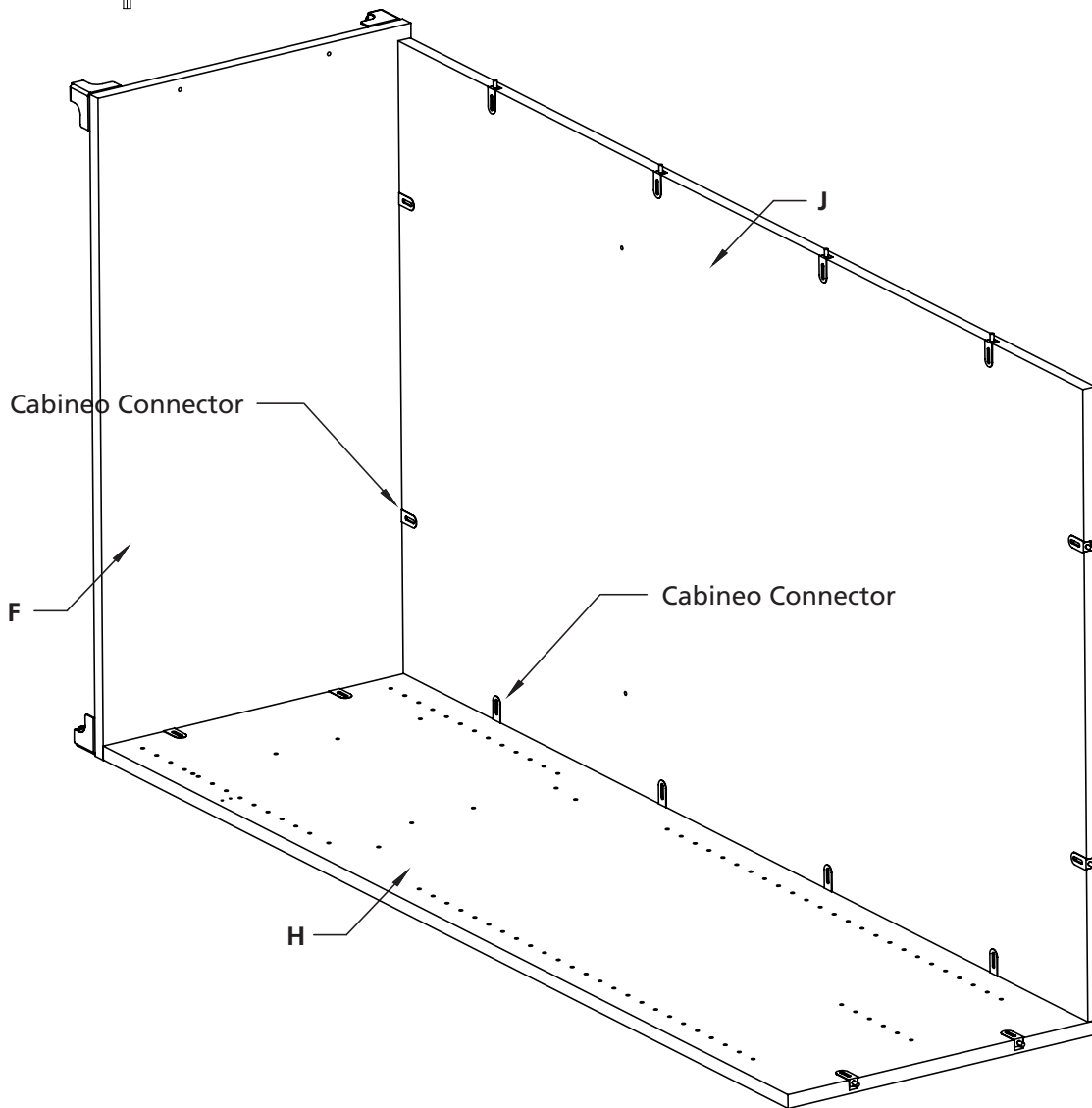
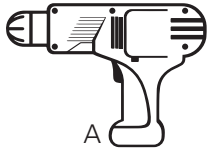

Figure A



Step 3

- Take the back panel (J) and align the cabineo connectors with the pre-drilled pilot holes on the bottom panel (F) and the right panel (H).
- Using the 4mm ball end screwdriver (C), screw the four cabineo connectors on the back panel (J) to secure it to the right panel (H).
- Using the 4mm ball end screwdriver (D), screw the two cabineo connectors on the back panel (J) to secure it to the bottom panel (F).



Step 4

- Take the shelf panel (K) and align the cabineo connectors with the pre-drilled pilot holes on the right panel (H) and the back panel (J).
- Using the 4mm ball end screwdriver (C), screw the two cabineo connectors on the shelf panel (K) to secure it to the right panel (H).
- Using the 4mm ball end screwdriver (D), screw the two cabineo connectors on the shelf panel (K) to secure it to the back panel (J).

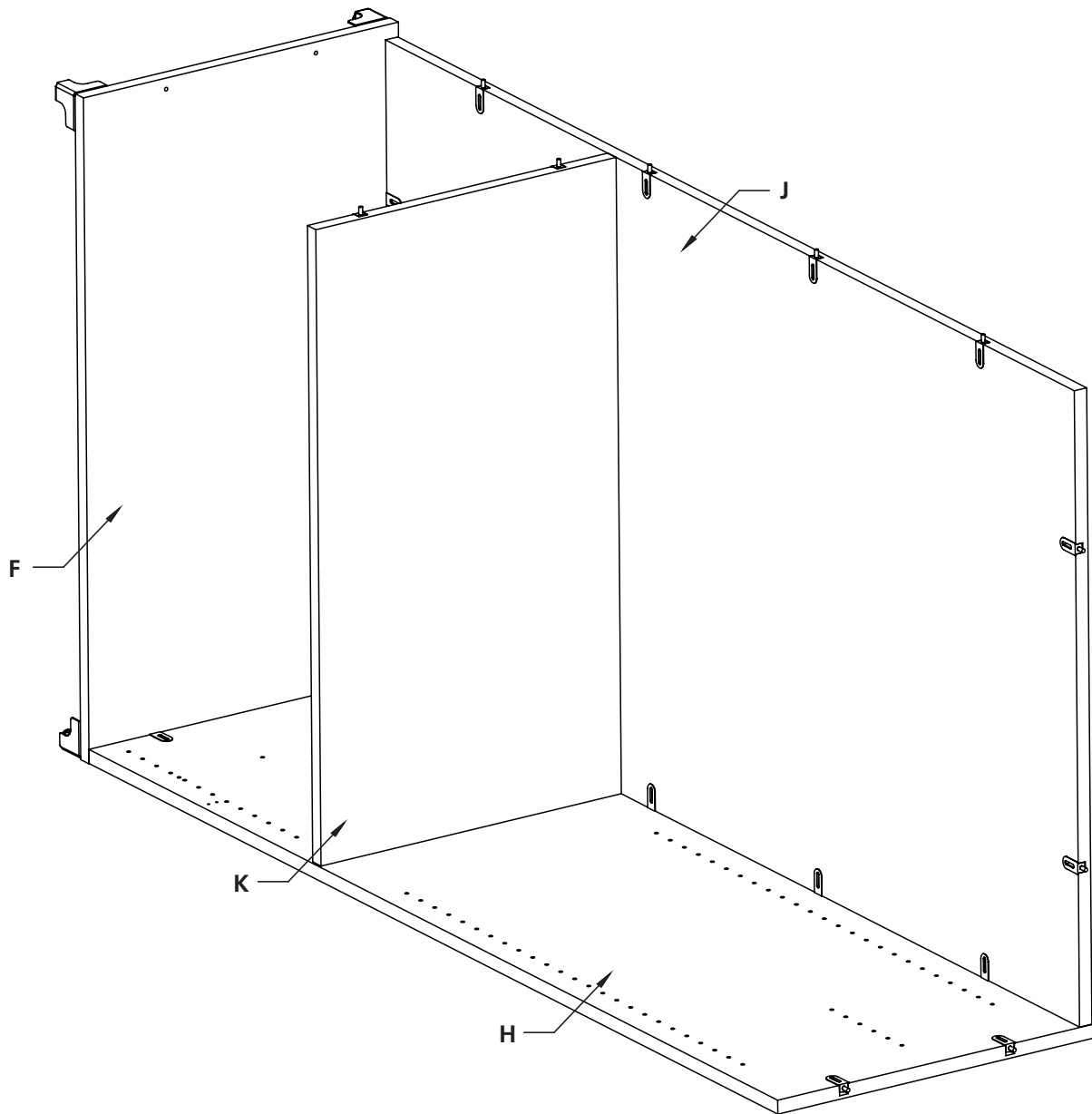
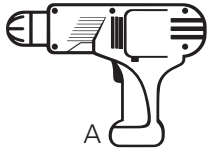

Step 5

- With the help of another person, place the wardrobe rightside up.
- Take the left panel (I) and align the pre-drilled pilot holes with the cabineo connectors on the back panel (J) and the shelf panel (K).
- Using the 4mm ball end screwdriver (C), screw the two cabineo connectors on the bottom of the left panel (I) to secure it to the bottom panel (F).
- Using the 4mm ball end screwdriver (D), screw the two cabineo connectors on the shelf panel (K) to secure it to the left panel (I).
- Using the 4mm ball end screwdriver (D), screw the four cabineo connectors on the back panel (J) to secure it to the left panel (I).

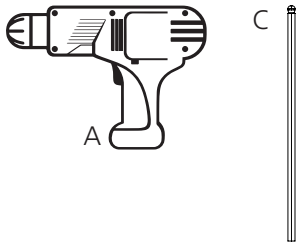
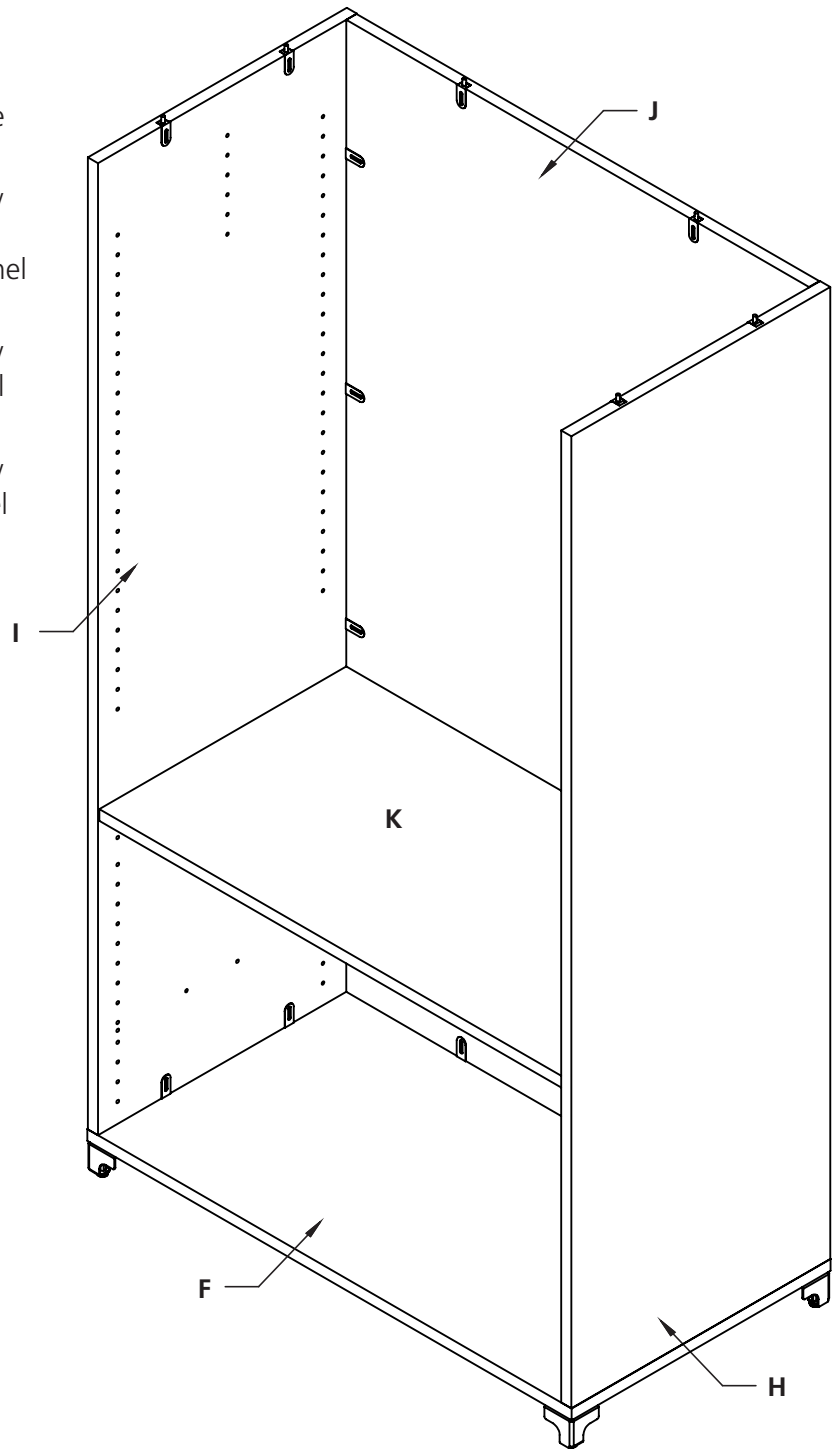

Step 6

- Take the top panel (G) and align the pre-drilled pilot holes with the cabineo connectors on the back panel (J), left panel (I), and right panel (H).
- Using the 4mm ball end screwdriver (C), screw the cabineo connectors on the back panel (J), left panel (I), and right panel (H) to secure it to the top panel (G).

