

## Grommet Type

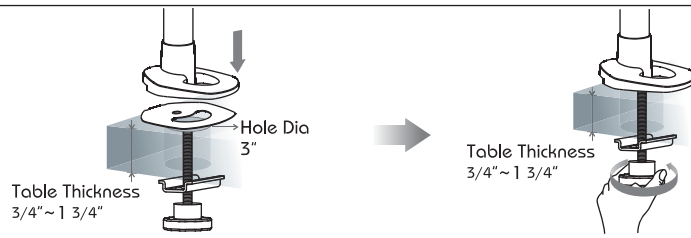

## Clamp Type

**Step 1** → Unscrew Hand-Turn Screw and separate Hand-Turn Screw and Long Metal Plate from the Mount.

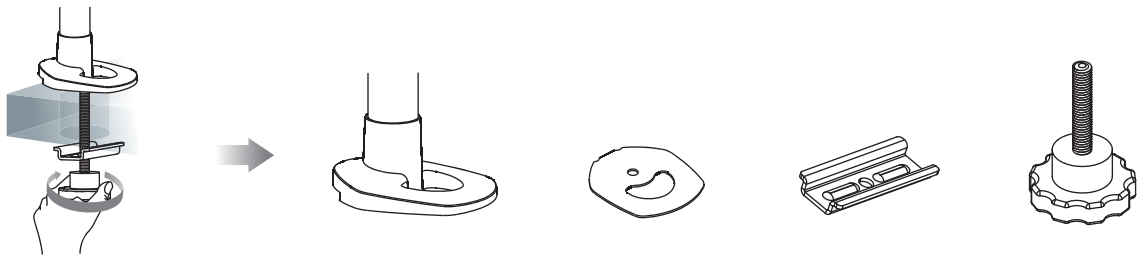

### Service Kit (#52487)

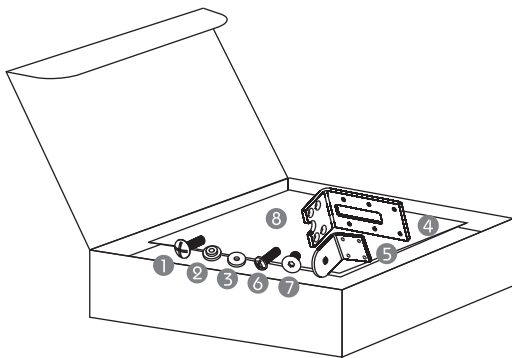

①	Screw M4x15mm, Round Head, Philips Drive	1
②	Male Round Washer	1
③	Female Round Washer	1
④	Metal C Clamp(L)	1
⑤	Metal C Clamp(S)	1
⑥	Screw M6x14mm, Round Head, Philips Drive	4
⑦	Screw M5x14mm, Flat Head, Hex Socket Screw	4
⑧	Pole with Clamp/Grommet Attachment User's Manual	1

**Step 2** → Depends on the desk thickness, assemble 2 pieces of metal clamp at suitable screw holes with 4 screws (M5x15mm, round head, Philips Drive).

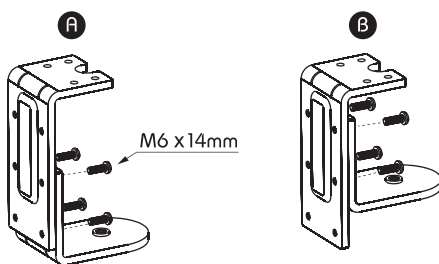

### Remark

Desk thickness >50mm(1.97"), refer to chart A left.

Desk thickness <50mm(1.97"), refer to chart B left.

**Step 3** → Get Screw (M4x15mm, Round Head, Philips Drive), Male & Female Round Washers from Service Kit.



**Step 4** Assemble Hand-Turn Screw with C Clamp.

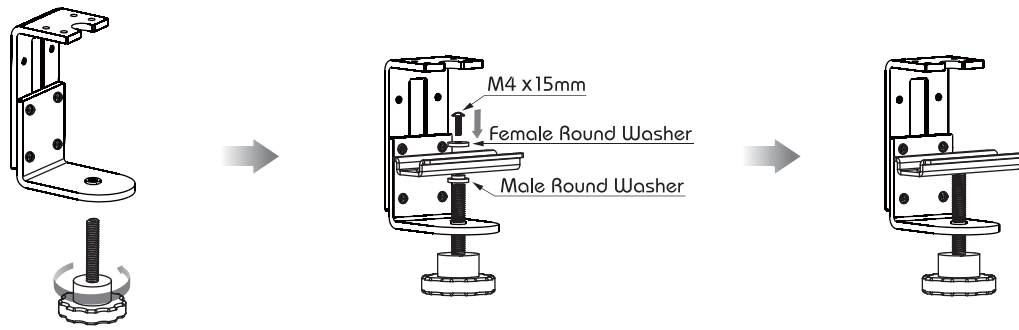

**Step 5** Assemble C Clamp with Mount by driving 3 Screws M5x15mm, flap head, Hex Socket Screws.

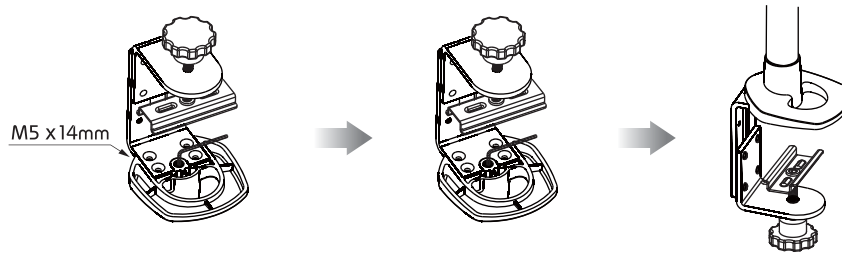

**Step 6** Stick EVA cushion to mount bottom. Mount assembly is completed for installation onto desk.

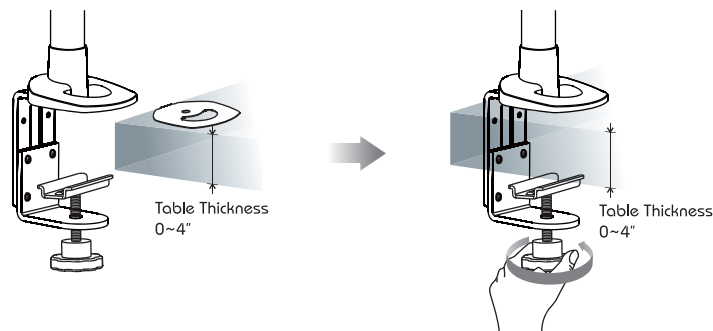

**Step 7** Install Mount with Swivel Arm, Spring Arm, and Monitor Bracket.

**Parts & Hardware**

Parts	QTY	Remark	Parts	QTY	Remark
Mount with Pole, Pole Cap, and Adjustment Ring	1	No Adjustment Ring on 82mm Clamp Mount	Female Round Washer	1	Inside Service Kit
Hand-Turn Screw(Attached with Mount)	1		Metal C Clamp(L)	1	Inside Service Kit
EVA Cushion (Attached with Mount)	1		Metal C Clamp(S)	1	Inside Service Kit
Long Metal Plate(Attached with Mount)	1		Screw M6x14mm, Round Head, Philips Drive	4	Inside Service Kit
Screw M4x15mm, Round Head, Philips Drive	1	Inside Service Kit	Screw M5x14mm, Flat Head, Hex Socket Screw	4	Inside Service Kit
Male Round Washer	1	Inside Service Kit	Pole with Clamp/Grommet Attachment	1	Inside Service Kit
			User's Manual		

**Tool**

Tools Item	QTY	Remark
M3 Wrench	1	Inside Service Kit of Monitor Bracket
#3 Philips Screw Driver	1	Prepared by users



info@raproducts.com  
www.raproducts.com  
800.298.4351