



ergonomic products

K&A MANUFACTURING

6703 ZINSER ST., SCHOFIELD, WI 54476

PHONE: 800.298.4351 FAX: 866.882.9475

www.raproducts.com

VERSION DATED: 8/2/17

TOOLS REQUIRED FOR ASSEMBLY:
PHILLIPS SCREWDRIVER

XRCDDP DELTA DIVIDER PANEL
INSTALLATION INSTRUCTIONS:

SMALL WORKSURFACES NOT SHOWN
FOR ASSEMBLY CLARITY.

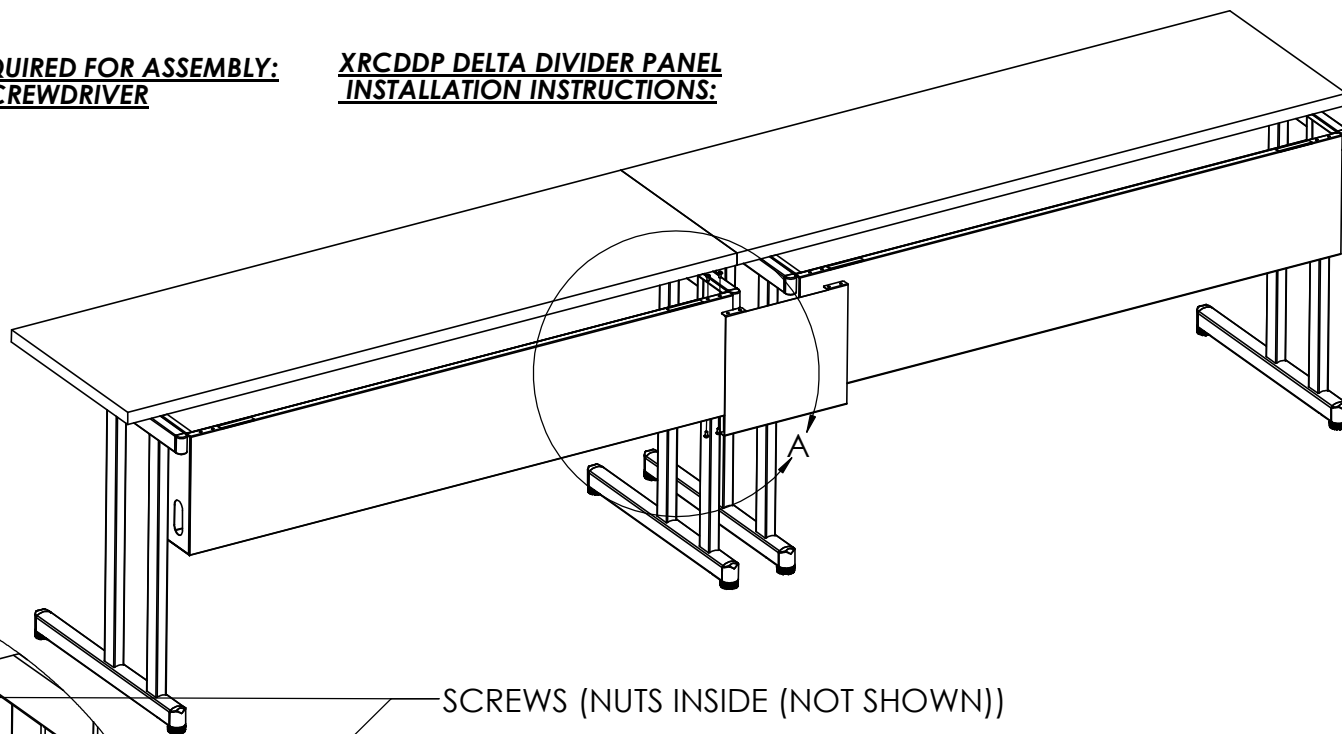

SCREWS (NUTS INSIDE (NOT SHOWN))

- STEP 1: ARRANGE DELTA WORKSTATIONS SIDE BY SIDE.
- STEP 2: PLACE DELTA DIVIDER PANEL AS SHOWN AND ALIGN HOLES.
- STEP 3: PLACE 4 SCREWS THROUGH TOP AND BOTTOM HOLES.
- STEP 4: THREAD THE NUTS ONTO SCREWS AND TIGHTEN.

NOTE: WE RECOMMEND ATTACHING ONE SIDE ONLY.
EITHER SIDE CAN BE USED.
IF THE TABLE IS MOVED OR FORCED OUT OF LINE, THIS
WILL PREVENT DAMAGE TO THE DIVIDER PANEL.

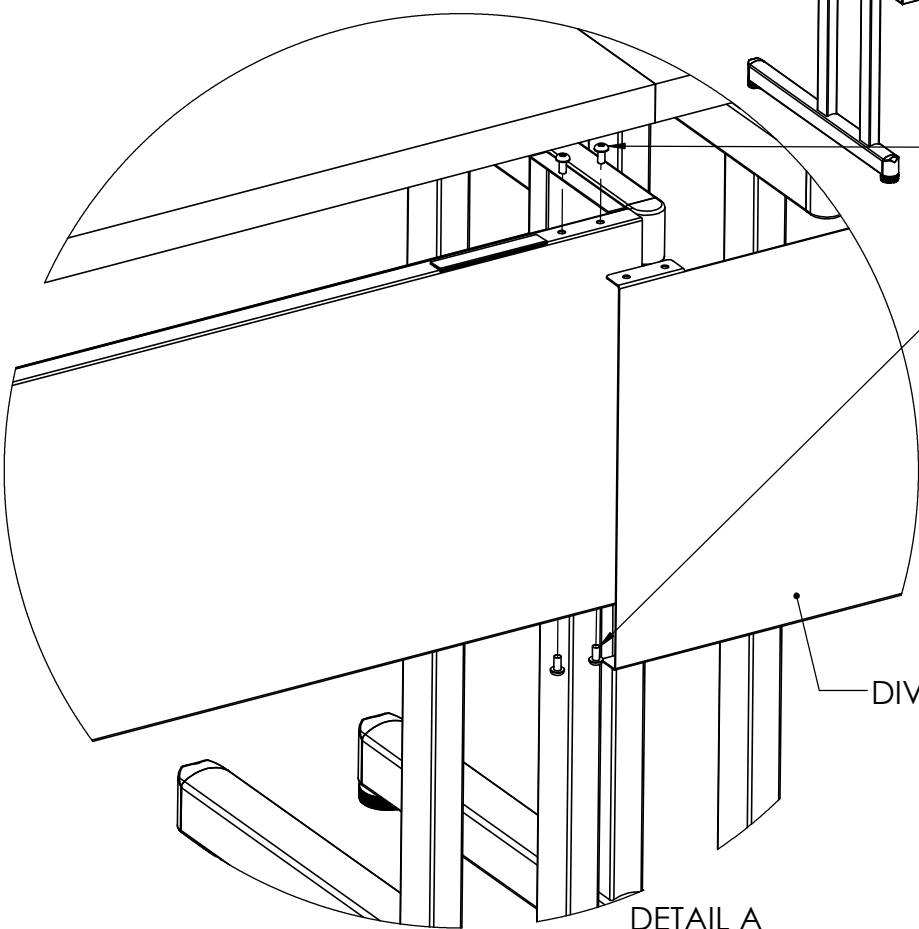

DIVIDER PANEL

DETAIL A