



SILENCERCO OCTANE

FIELD MANUAL

WARNING

Failure to follow installation and maintenance instructions detailed in this manual may result in serious personal injury and damage to the weapon. Firearm sound suppressors are user-attached firearm muzzle devices, and as such, are subject to improper attachment issues unless the procedures outlined in this manual are followed precisely. Do not attempt to use this product unless you have specific training and experience in the use of firearms.

Before installing or removing the Octane sound suppressor from the host weapon, be sure that the weapon is unloaded and the action is opened so that it is visibly clear of any ammunition. If you are at all unsure as to the proper procedures

to ensure that your firearm is unloaded, please consult your firearm user's manual/instructions and contact a properly licensed dealer or the manufacturer of your weapon.

Because suppressed firearms make less noise than unsuppressed firearms, it is easy to forget that they are still firearms and capable of causing bodily injury and property damage. It is of vital importance to remember that a suppressed firearm is just as dangerous as an unsuppressed firearm, and that the same safe handling requirements still apply.

When removing the Octane, use extreme caution as it may be hot to the touch after firing. Use gloves to avoid burns or other injuries.

Check the fit between barrel and suppressor before firing! The thread mount must be fully shouldered on the barrel. There should be no visible gap between the barrel shoulder and the face of the suppressor thread mount. If there is any gap DO NOT fire the host with the suppressor attached. Poor accuracy and product damage may result if the suppressor is not fully shouldered.

Assembly and disassembly should never be performed while the suppressor is affixed in any manner to a host firearm. Always completely remove the Octane from the host firearm before assembly and/or disassembly is attempted.

Before performing maintenance, removing, or installing the suppressor, open the action, ensure firearm is unloaded, and be sure the chamber is empty. Failure to do so can result in property damage, injury, or death.

MADE IN USA

We manufacture all of our products under one roof here in the USA and are proud to deliver only the best silencers to our community.

Featuring an interchangeable mounting system and CTA™ (Click Together Assembly) baffles, the Octane series is a innovative, user-maintainable family of silencers that provide you with the best suppression for both pistols and

submachine guns. Sound reduction will vary based on your firearm's caliber and ammunition, but the Octane is capable of bringing decibels down to as low as 129 dB at the muzzle—well below the 140 dB threshold level set by OSHA. After just a few rounds you'll never go back to shooting unsuppressed.

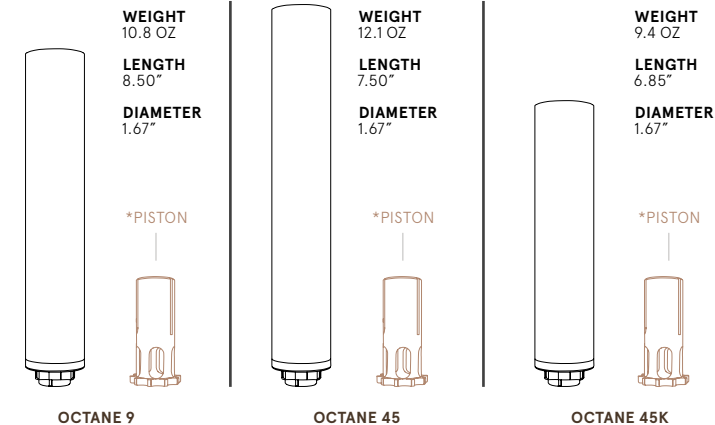

PRODUCT SPECS

The Octane includes a spring retainer with booster spring and we offer several threaded ***pistons (not included)** for different host firearm. Installing the correct piston in your Octane is essential to ensuring proper and safe compatibility with your firearm. Before purchasing a piston, confirm that the thread pitch matches that of your barrel.

Visit [SILENCERCO.COM/PRODUCT-SUPPORT](https://silencerco.com/product-support) for detailed thread diagrams or consult firearm manufacturer.

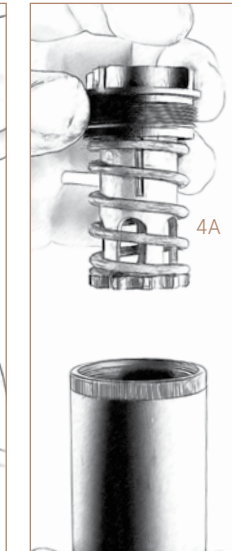

INSTALLATION & REMOVAL

Unscrew and remove spring retainer (1A) and booster spring (2A) from the back of the silencer. Disassemble into two separate components. Place booster spring over Octane-compatible piston (3A) and seat into spring retainer, returning booster components to their original configuration.

In the case of the 3-Lug Mount, see the 3-Lug Mount section that follows.

Align and insert updated booster (4A) back into the rear of the silencer; hand tighten until booster is seated securely.

After booster is installed, align back of silencer with the threaded barrel of host firearm (5A); hand tighten until it is seated securely against the shoulder of your barrel.

Silencers may unscrew during firing. It is of the utmost importance that you frequently verify that the silencer is securely tightened. We recommend checking every 30 rounds.

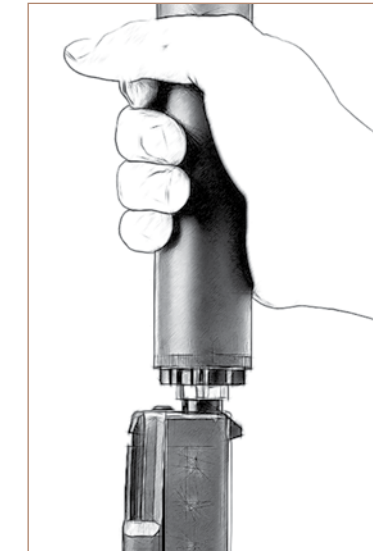

1B



3-LUG MOUNT

The 3-Lug Mount (1B) is a push-and-twist bayonet mounting system for use on all 9mm HK-style, 3-lug equipped firearms. This accessory ships with the tool required to install it.

To install 3-Lug Mount, first unscrew and remove the spring retainer and booster spring (2B) from the rear of the silencer. Insert the 3-Lug Mount into the rear of the silencer and align the three pins of the provided tool with the three lugs on the mount. Insert pins into holes and, while pressing firmly, rotate the tool so the mount engages the threads (3B). Continue to thread the mount into the Octane until hand tight.

To install silencer on the host, align the grooves on the silencer with the lugs on the barrel or adapter. Pull the silencer onto the barrel against the spring tension and rotate the silencer counter-clockwise until it stops. Release the silencer; it should move forward approximately 1/10", where it will rest against the lugs. Gently pull forward on the silencer and twist from side to side to ensure a secure mounting.

To remove the silencer, depress against the lugs and turn clockwise. Pull the silencer forward.

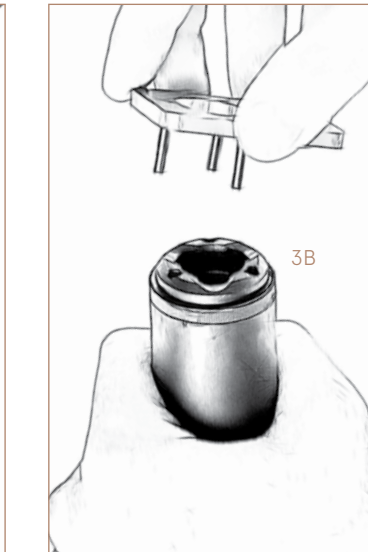
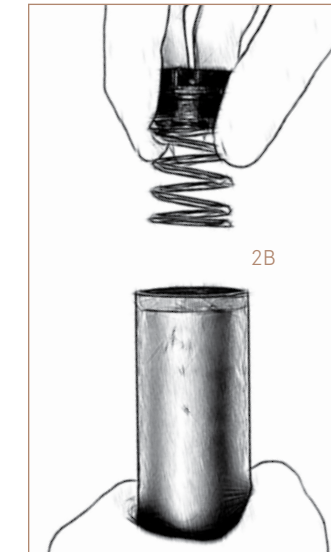

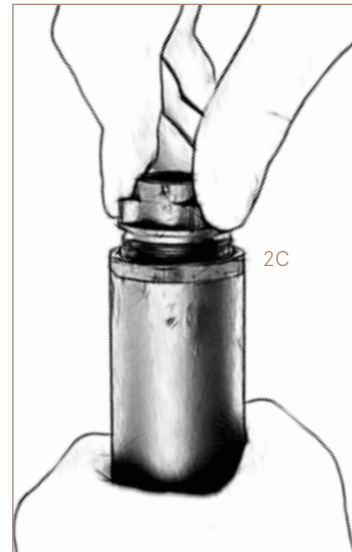
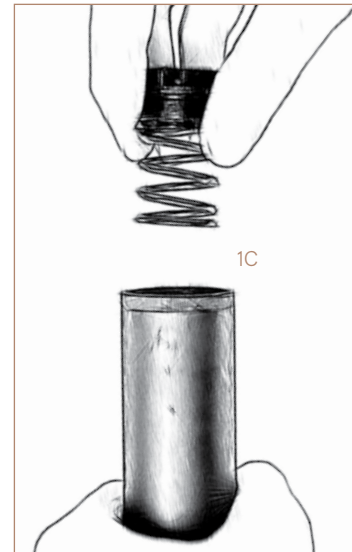

FIXED MOUNT

The Octane Fixed Mount is required for use on firearms that are equipped with a fixed barrel.

To install, first unscrew and remove the spring retainer and booster spring from the rear of the silencer (1C). Insert the Octane Fixed Mount into the rear of the silencer and rotate until hand tight (2C).

DISASSEMBLY

Unscrew and remove booster from the back of the silencer. Disassemble into three separate components.

Use sprocketed end of piston to unscrew front cap of silencer (2D).

Using a 3/4" wooden dowel, gently push baffle stack towards the front end of the silencer until it has exited silencer tube (3D).

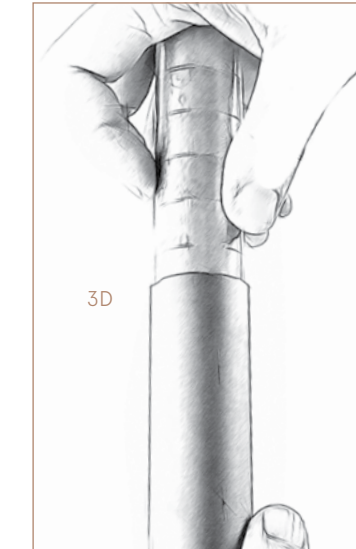

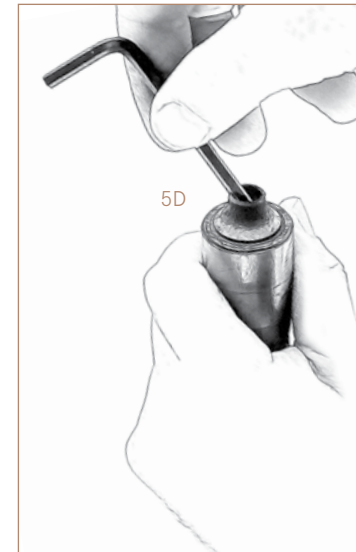
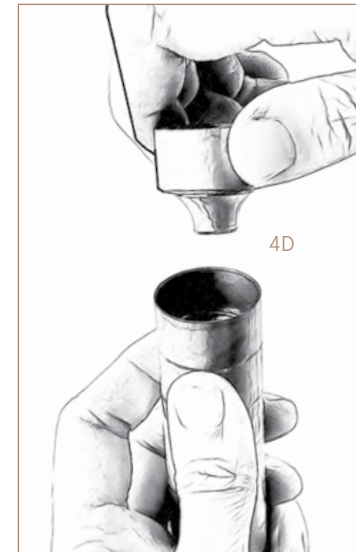

Pull apart baffles one at a time until they are all separated (4D).

Sometimes baffle stack can become hard to separate. If this happens, seat Allen wrench into the notch of the exposed cone (5D) and leverage to pry baffle away from stack.

ASSEMBLY

Align all baffles to face in the same orientation (1E) and click together to create a baffle stack (2E). Baffles are all the same (except for Octane 45, which has one shorter baffle) and can be assembled in any order.

Ensure all baffles are properly seated together and no open seams exist between them.

Snap the expansion chamber (3E) onto the exposed cone end (not flat end) of the baffle stack so that the ridge inside the expansion chamber is closest to the cone.

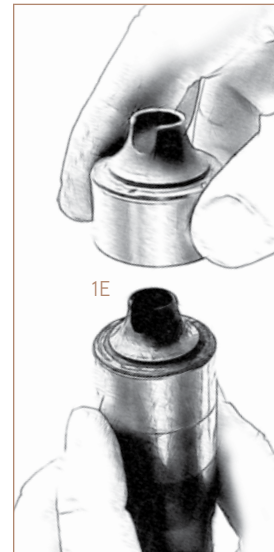

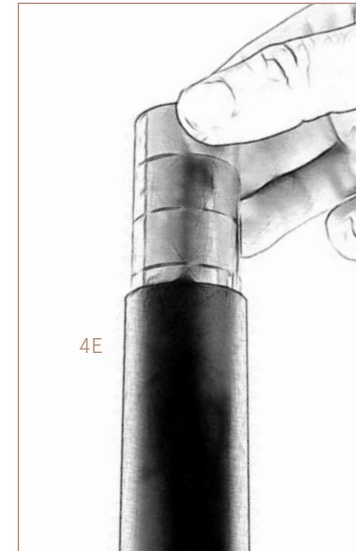

Slide baffle stack with attached expansion chamber into the silencer tube (4E), expansion chamber first, until it stops against the booster housing inside the tube.

Twist front cap onto silencer; hand tighten with the sprocketed end of piston (5E).

Assemble mount components as outlined in the Installation & Removal instructions and insert back into the silencer, threading it until hand tight.

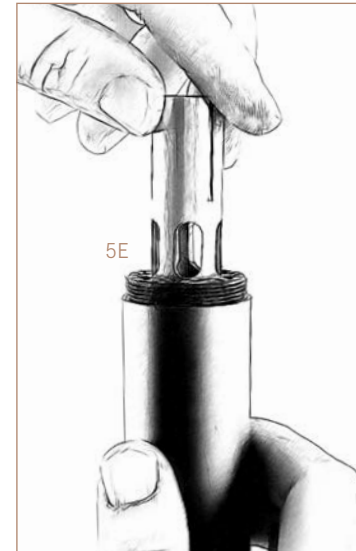

O-RING MAINTENANCE

Inside the indexing ring/spring retainer is an O-Ring, which seals the gases from escaping the silencer when the piston is actuated during firing. It should be noted that the Octane will function without the O-Ring, but it is necessary to achieve the most effective sound suppression. The O-Ring will need to be replaced once you notice a substantial amount of wear and tear after heavy use or after breakage occurs. At this point, simply disassemble the booster and insert a new O-Ring (Viton Rubber Size -018) into the groove on the inside of the spring retainer, directly under the threads.

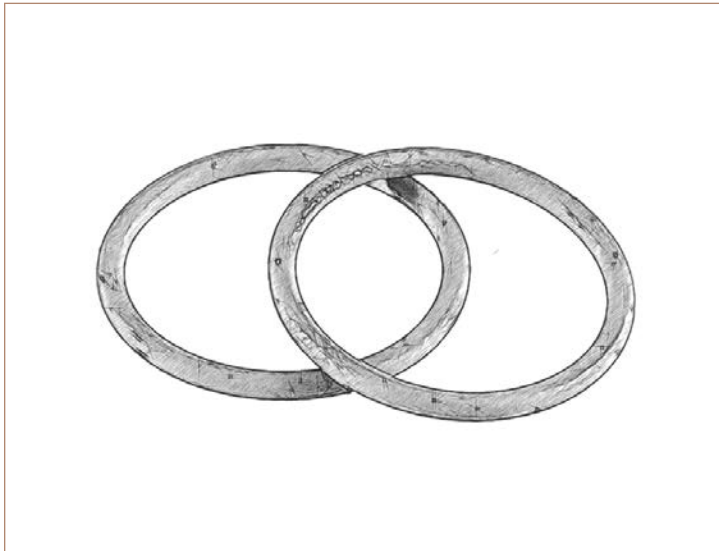

SERVICING THE BOOSTER

The Nielsen Device/Booster should be regularly cleaned. Remove the booster and disassemble all parts. Using an abrasive brush and/or scotch bright pad and solvent, scrub the components free of the carbon build up. When finished, apply white lithium grease, break free, or light gun oil to the O-Ring inside the spring retainer, assemble the booster, and install into the back of the suppressor.

Do not use sand paper to clean the booster, as it could ruin the precision finish and cause malfunction.

After use and before disassembling the booster, spray break free into the booster through the bore hole and through the piston vents so that it enters the inside of the booster assembly. This will allow for greater ease of disassembly.

CAUTION Always read the warning label on any cleaner or solvent, and remember that virtually all solvents are inherently dangerous and potentially toxic. Always use adequate ventilation and both skin and eye protection when using solvents.

MAINTENANCE

The Octane is designed to be easily maintained by the user. It is recommended that the silencer and its individual components be disassembled and cleaned at intervals of 500 rounds, or whenever the silencer is shot “wet”. Each component has a suggested method for cleaning.

- Aluminum parts should not be soaked in solvent due to the potential for damage to the finish. To clean the baffles, we recommend using a damp cloth or non-abrasive brush to gently wipe or scrub away debris.
- To clean the booster, use break free to make removal from silencer tube easier and disassemble. Use an abrasive brush or pad and solvent to scrub away carbon buildup. Do not use sand paper as it could ruin the finish and cause malfunction.
- Inside the indexing ring of the spring retainer is an O-Ring, which seals the gases from escaping the silencer when the piston is actuated during firing. While the Octane will function without the O-Ring, it is necessary to achieve

the most effective sound suppression. To maintain, use white lithium grease, break free, or light gun oil. The O-Ring will need to be replaced once you notice a substantial amount of wear and tear after heavy use or after breakage occurs. To replace, simply disassemble the booster and insert a new O-Ring into the groove on the inside of the spring retainer, directly under the threads.

- Always read the warning label on any solvent, and remember that virtually all solvents are inherently dangerous and potentially toxic. Be sure to use adequate ventilation and both skin and eye protection.

Should additional cleaning advice be required, contact our Customer Service team at **801.417.5384**.

Shooting “wet” implies that water or a lubricant has been placed inside the silencer as a way to aid in the cooling of gases and increase sound suppression.

LIFETIME WARRANTY

We proudly stand behind the quality of our products with a lifetime warranty, no matter what—even if it's not a product defect. Our 48 hour repair turnaround even warranties stupid... once. If you experience any issues, please contact our Customer Service team at **801.417.5384**.

If your silencer has a defect in manufacturing or materials, there will be no charges for service or replacement through our SilencerCo facility.

If we determine that a claim is not covered under warranty, a discounted replacement option will be granted.

This warranty does not cover damage to the silencer or host firearm resulting from careless or irresponsible handling, adjustments or modifications to design, negligence, or other abuse. SilencerCo assumes no liability for unsafe or illegal use of the silencer by its purchaser or any other user that comes in contact with the product after purchase. SilencerCo assumes no responsibility for physical

injury or property damage resulting from careless or irresponsible handling or by any use contrary to the recommendations, warnings, and cautions generally listed in this manual. SilencerCo does not cover damage to the silencer or host firearm resulting from improper hand-loaded or reloaded ammunition or defective ammunition

SONIC CRACK

The Octane is designed to suppress the initial muzzle blast and subsequent projectile de-corking pressure. The Octane does not contact or otherwise interact with the projectile, allowing the projectile to travel at its default speed.

Because of this, a sonic crack is produced by the projectile as it breaks the sound barrier. Depending on the geography of the area, the sonic crack may vary in volume. This is solely a function of the projectile breaking the sound barrier and is not related to suppressor performance.

**REGISTER YOUR SILENCERCO PRODUCT ONLINE
TO ACTIVATE YOUR LIFETIME WARRANTY**

SILENCERCO.COM/REGISTER

FOR QUESTIONS, CONTACT OUR CUSTOMER SERVICE TEAM AT 801.417.5384 OR INFO@SILENCERCO.COM

© 2019 SilencerCo, LLC. All Rights Reserved. The contents of this publication may not be reproduced in any form or by any means in whole or in part without the prior written permission of the copyright owner.

JOIN NOW



Protect Your Rights | Protect Your Hearing

The American Suppressor Association is fighting to protect and expand your silencer rights. Join the fight today!

LEARN MORE AT AMERICANSUPPRESSORASSOCIATION.COM

