

VG60 ELECTRONIC VACUUM GAUGE

Thank you for purchasing our VG60 Vacuum Gauge. It is an accurate instrument with original features. Please read these instructions carefully to get the best performance and many years of trouble-free service from your VG60.

OPERATING CONTROLS AND FUNCTIONS

1. ON-OFF slide switch.
2. Dual purpose LED indicator.
 - A. Illuminates when slide switch is ON.
 - B. Hardly glows, or may not illuminate when battery is low.
3. LED lamps indicate the entire range for vacuum pump from atmosphere down to 50 microns vacuum.
4. Tough high impact case.
5. Standard 1/4 inch male flare fitting.
6. Quick cap for fitting.
7. Built-in hanger.
8. Tilt up cover for battery compartment.
9. Compartment for 9 volt battery.
10. Calibration screw.

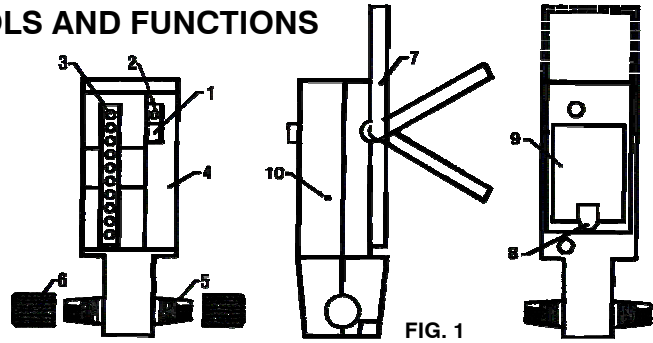

HOW TO USE VG60 ON REFRIGERATION SYSTEMS

The purpose of this introduction is to aid the service engineer in evacuating any system by the most efficient method. The capacity of a vacuum pump is defined by how fast the pump can evacuate a system; and the efficiency of the pump is defined by how deep a vacuum it is capable of pumping over a length of time. The level of vacuum you want to achieve can only be determined by a vacuum gauge.

Most service engineers who are experienced in evacuating systems know beforehand the approximate time the vacuum pump will have to run.

However, the only proof he has that the system is actually empty is by the reading of a vacuum gauge.

We have researched the numerous arrangements of using shut off valves and have found the subsequent valve layout to be the most versatile and efficient. (Fig.2)

The following recommendations will help you pull a vacuum in the shortest possible time:

1. The valves and connecting tubes (Fig.2) that are in-line from the refrigerating unit to the pump should be of the same ID (size and type) as the original fitting on the suction side of the pump.
2. Always pull a vacuum simultaneously from the high and low side of the system.
3. If you must connect your hose to an access fitting on the system, first remove the core.
4. Use the shortest possible length of hose.

Oil vapors from a vacuum pump will contaminate all electronic vacuum gauges. Oil vapors are produced after the running pump has stopped. The air at atmospheric pressure rushes into the vacuum side of the pump causing an oil turbulence. Most pumps are equipped with a check valve, but it only takes a tiny amount of vapor to affect the electronic sensor. The following simple precautions will assure you of many years of trouble free service. Referring to (Fig.2):

Before you stop the vacuum pump.

1. Close the pump valve first.
2. Close the vacuum gauge valve.

Before you start the vacuum pump.

1. Close all valves.
2. Start the pump.
3. Open pump valve.
4. Gradually open main valve, wait 5 seconds before opening gauge valve.

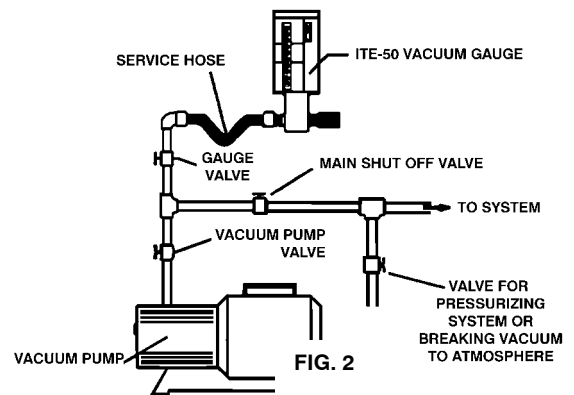

MAINTENANCE

The VG60 electronic vacuum gauge sensor is cleanable. It is good maintenance practice to clean the sensor periodically. Use an eyedropper to pour about 2 teaspoons of ordinary rubbing alcohol into the fitting. Cap the fitting and shake about 10 seconds; empty and air dry. (The slight movement of the fitting in the case is normal and does not affect the internal connection in any way.)

When transporting the VG60 as a separate unit, close both ends with the quick caps.

EVACUATING A REFRIGERATION SYSTEM

Emptying a system of all its vapors, including moisture, is a matter of time, and the length of time depends upon:

1. Size of the vacuum pump.
2. Efficiency of the pump.
3. The size of the system.
4. The distance of the furthest part of the system to the pump.

The most common time destroyer is an inefficient vacuum pump or a leak in the system that is discovered after an hour of pump running time. To prevent both from happening, test for leaks before you start the vacuum pump by closing all the valves except for the pressurizing valve. When you've completed the leak test and you are removing the test pressure gas, you can test the pump for efficiency by leaving the main valve closed and opening the pump and vacuum gauge valve. This is called a blank-off test. The vacuum gauge shows the lowest possible vacuum the pump is capable of pulling. This one time blank-off test does not guarantee that the pump will be that efficient after it gets hot from running more than 15 minutes. There are many instances where the oil in the pump should be changed, and it becomes obvious only when the pump is running hot.

If you estimate, for example, that the vacuum pump should evacuate the system in about 1 hour, it would be a smart plan to periodically check the pump for efficiency. It only takes a few seconds. After the blank-off test, close the pump valve and open the main valve. The reading on the VG60 tells you the vacuum level the system is at. Each time you test the system for its vacuum level, there should be a progressive reduction in the micron level. If the reading remains at the approximately 1,000 micron level, there is either some gas pockets that are being drawn from the oil in the system or moisture in the system. In either case, if you know that the compressor is efficient and there aren't any leaks in the system, it is going to be a matter of time to evacuate down to your target level.

HOW LOW A VACUUM SHOULD YOU PULL ON A SYSTEM?

Ever since vacuum pumps have been used in ON-SITE situations, the low pressure figure has been a judgement call with the individual service engineer and contractor's policy. At some educational seminars, caution was expressed on going below 300 microns because the compressor oil would be evaporated. Oil companies, who supply the industry with compressor oil, have discounted this theory. After interviewing many experienced service engineers we have found that the average low pressure target most service engineers look for on large systems is about 700 microns and on small systems about 400 microns.

CALIBRATIONS

The micron pressure readings have been calibrated at the factory. It is permanent and never needs re-setting. However, due to seasonal temperature variations, you may have to make a slight ambient adjustment. The gauge is perfectly calibrated when, after you push the slide switch to ON, both the atmosphere and slide switch lamps are energized. Should the 5,000 micron lamp go on instead of the atmosphere lamp, insert a small screw driver into the opening at the side of the case (No. 10 in Fig.1), locate screw and make the adjustment until only the atmosphere and slide switch lamps go on. Do not overturn the screw, it may turn off the atmosphere lamp.

OPERATION

WHEN CONNECTING HOSES TO THE VG60, DO NOT USE WRENCHES OF ANY KIND. USE ONLY SERVICE HOSE CONNECTIONS WITH A KNURLED FITTING ON THE END. THE HAND TIGHT CONNECTION OF A SERVICE HOSE IS AN ADEQUATE CONNECTION.

After you have connected the vacuum pump to the system, close all valves.

1. Run vacuum pump. 2. Gradually open main valve and pump valve. 3. Open valve to vacuum gauge. 4. Allow 15 seconds for sensor to stabilize. During the initial stages of evacuation, the atmosphere lamp may go out. This is normal when large volumes of air pass by the sensor. As the lamps indicate the vacuum levels in the system, 2 lamps may be energized at the same time. This is normal when there is a transition from one range to the next.

LOW BATTERY INDICATION

If the LED indicator (No.2, Fig.1) is not as bright as the other lamps, or it doesn't light at all, the battery should be changed. (Use only Alkaline batteries.)
REMINDER: ALWAYS SHUT OFF THE GAUGE VALVE BEFORE YOU STOP THE VACUUM PUMP.

SPECIFICATIONS:

SENSOR TYPE	Thermistor	LOW BATTERY INDICATOR.....	LED
VACUUM RANGE	5000 Microns	DIMENSIONS.....	1-1/2" X 1-3/4" x 5-3/4"
SCALE INDICATORS.....	LED	WEIGHT .	6-1/2 Oz.
POWER SOURCE.....	9 Volt Alkaline Battery (Not included)	120 VAC ADAPTOR.....	Optional,
CONTINUOUS USAGE	20 Hours (With a new battery)		Order as Part No. DPG-T

VG60 TROUBLESHOOTING GUIDE

ALWAYS MAKE SURE THERE IS NO LEAK IN THE SYSTEM BEFORE YOU START TO PULL A VACUUM

PROBLEM...ERRATIC READINGS

SOLUTION...The sensor is contaminated with oil vapor. Clean the sensor as described in the Maintenance section.

PROBLEM...ATMOSPHERE LED IS DIM OR DOESN'T LIGHT.

SOLUTION...Weak batteries. Replace with new Alkaline batteries only.

PROBLEM...5,000 Micron LED LIGHTS INSTEAD OF ATMOSPHERE LED.

SOLUTION...Possible cause is excessive seasonal ambient temperature change. Make calibration adjustment as described in Calibration section.

PROBLEM...AFTER UNIT HAS BEEN RUNNING AT 1,000 MICRONS YOU SHUT OFF THE PUMP VALVE, VG60 RISES FAST TO 1,500 MICRONS.

SOLUTION...The vacuum at the gauge is 1,000 but the system is still 1,500 microns. This is a normal condition where there is a small diameter tube between the vacuum pump and the system causing the pressure drop. As you continue to run the pump and the vacuum level goes to 700 or less, the pressure difference will decrease. The best solution will be to use a very short length of tube with the same ID as the fitting on the vacuum pump.

PROBLEM...AFTER THE UNIT IS RUNNING AT ABOUT 1,000 MICRONS, YOU SHUT OFF THE PUMP VALVE. THE READING OF THE VG60 RISES SLOWLY TO 1,500 MICRONS OR MORE.

SOLUTION...There is still more refrigerant or moisture in the system. Continue to pump down to the recommended level.

COMMONLY ASKED QUESTIONS

QUESTION...WHEN CONNECTING THE VG60 TO THE SYSTEM, SHOULD I USE AN AUXILIARY FITTING ON MY VACUUM PUMP OR USE A SERIES (IN-LINE) HOSE CONNECTION TO BOTH SIDES OF THE VG60?

ANSWER...Do not use the VG60 as a series connection from the vacuum pump to the system. This will definitely cause a pressure drop. Most vacuum pumps have a fitting near the suction inlet of the pump. If you use this fitting for the VG60 there is no way to shut off the pump to see if there is a rise of vacuum in the system. Refer to Fig. 2.

QUESTION...IF I PULL A VACUUM TO 1,000 MICRONS AND CLOSE ALL THE VALVES, AFTER 10 MINUTES I THEN CHECK THE SYSTEM AGAIN. IF THE READING DID NOT CHANGE, DOESN'T THAT PROVE THAT THERE ISN'T ANY LEAKS IN THE SYSTEM?

ANSWER...No, running under high pressure, refrigeration systems may have leaks which are nearly impossible to detect under vacuum or low pressure conditions. The system should be tested for leaks by pressuring rather than by applying vacuum.

Whenever you close the valve at the vacuum pump and you notice a slow rise in the VG60 reading, it simply means that there is still some moisture or other vapors in the system. This condition makes it very important to check for leaks BEFORE you start to evacuate the system and eliminate all doubts of possible leaks.