

SECTION A-A

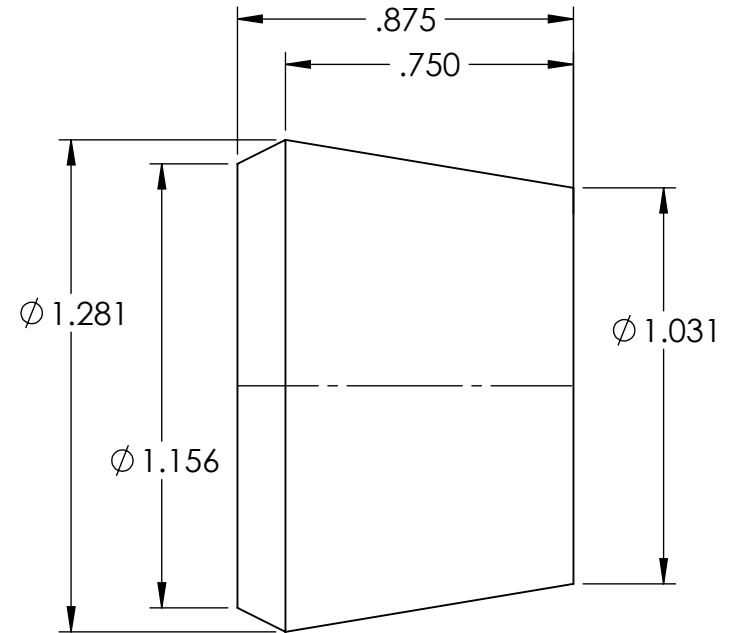

NOTES:

1. FLASH TO BE HELD TO A MINIMUM AND MAY NOT WEB ACROSS HOLES.
2. I.D. AND O.D. CONCENTRICITY .020.
3. ALL OTHER DIMENSIONS $\pm .015$.
4. MATERIAL: BLACK NEOPRENE 50-60 DUROMETER

REV.	DATE	CHANGE	UNLESS OTHERWISE SPECIFIED:	NAME	DATE	REMKE REMKE INDUSTRIES 310 CHADDICK DR, WHEELING, IL. 60090	
A	5/30/00	ADD NOTE ON TOLERANCE	DIMENSIONS ARE IN INCHES TOLERANCES: FRACTIONAL $\pm 1/64$ ANGULAR: MACH $\pm 1^\circ$ BEND $\pm 1^\circ$ ONE PLACE DECIMAL $\pm .015$ TWO PLACE DECIMAL $\pm .010$ THREE PLACE DECIMAL $\pm .005$	DRAWN	JCN	4/15	TITLE: <h1>BUSHING</h1>
B	4/15/15	REDRAWN		CHECKED			
				ENG APPR.			
				MFG APPR.			
				Q.A.			
			INTERPRET GEOMETRIC TOLERANCING PER:	PROPRIETARY AND CONFIDENTIAL THE INFORMATION CONTAINED IN THIS DRAWING IS THE SOLE PROPERTY OF REMKE INDUSTRIES. ANY REPRODUCTION IN PART OR AS A WHOLE WITHOUT THE WRITTEN PERMISSION OF REMKE INDUSTRIES IS PROHIBITED.		SIZE	DWG. NO.
			MATERIAL			A	SRB-306-2
			FINISH			SCALE: 2:1	
			DO NOT SCALE DRAWING			SHEET 1 OF 1	

5

↑

4

3

2

1