





Dog Fence Heavy Duty End Post Installation Instructions

Note: If a tension system was purchased, please refer to tensioning kit instructions **BEFORE** these instructions.

HARDWARE PARTS – DE90400			
A QTY: 2  1 5/8" Brace Cup Black SKU: DE8144	B QTY: 2  2 1/2" Brace Band Black SKU: DE8084	C QTY: 2  Carriage Bolt w/Washer & Nut Hot Dip Galvanized - 5/16" x 1 1/2" SKU: DE8042	D QTY: 2  2 1/2" Black Vinyl Post Cap SKU: DE8091
E QTY: 2  17 Gauge 2 1/2" Black Powder Coated Galvanized Pipe (See below for measurements)	F QTY: 2  17 Gauge 1 5/8" Black Powder Coated Galvanized Pipe (See below for measurements)	G QTY: 2  Self-Tapping Screw 3/4" SKU: DE9978-1	Recommended Tools (not included) Power Drill with 5/16" Drill Bit Socket Wrench 5/16" or Adjustable wrenches Shovel/Post Hole Digger Concrete/Expanding Post Foam

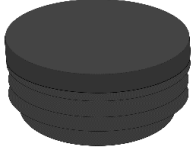
Pipes Part List						
	6' End			5' End		
	Qty	Pipe Measurement	SKU	Qty	Pipe Measurement	SKU
End Posts (E)	2	17 Gauge Black Powder Coated Galvanized Pipe 2 1/2" x 108"	DE8362-108	2	17 Gauge Black Powder Coated Galvanized Pipe 2 1/2" x 96"	DE8362-096
Brace Posts (F)	2	17 Gauge Black Powder Coated Galvanized Steel Pipe 1 5/8" x 84"	DE8358-084	2	17 Gauge Black Powder Coated Galvanized Steel Pipe 1 5/8" x 72"	DE8358-072
	4' End			3' End		
	Qty	Pipe Measurement	SKU	Qty	Pipe Measurement	SKU
End Posts (E)	2	17 Gauge Black Powder Coated Galvanized Pipe 2 1/2" x 84"	DE8362-084	2	17 Gauge Black Powder Coated Galvanized Pipe 2 1/2" x 72"	DE8362-072
Brace Posts (F)	2	17 Gauge Black Powder Coated Galvanized Steel Pipe 1 5/8" x 60"	DE8358-060	2	17 Gauge Black Powder Coated Galvanized Steel Pipe 1 5/8" x 48"	DE8358-048

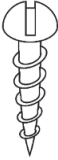
Dog Fence Heavy Duty End Post Installation Instructions

1. Lay out your fence design, taking care to note where your ends are going to be placed within the system.

Note: Ends should be placed anywhere the fence is terminating. Either against an existing structure like a house/shed or another fence line.

1.

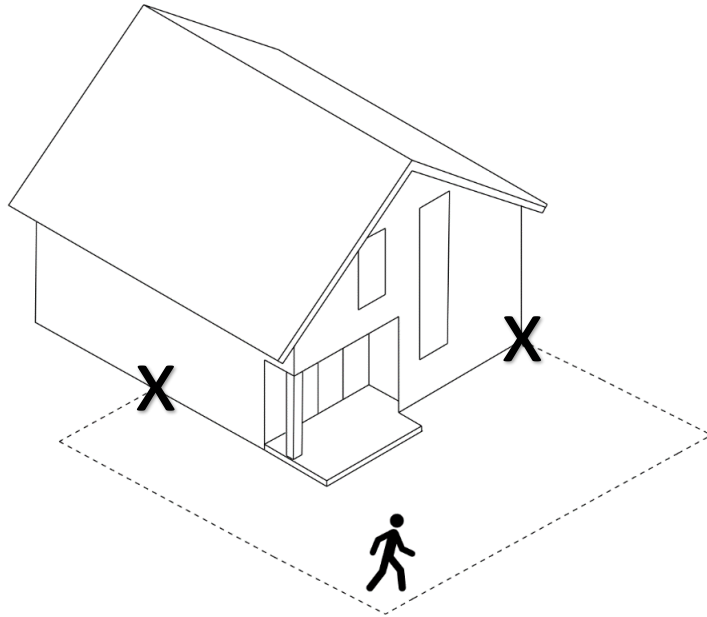

2. Place the **POST CAP (D)** into each **END POST (E)**. Then using a shovel or post hole digger, create a hole for the **END POST (E)**. Each hole should be **12" WIDE** and **36" DEEP**. Drop the **END POST (E)**, open end down, into the hole and then set with concrete. Make sure to allow the concrete to set completely before proceeding to **STEP 3**.

Note: It is **HIGHLY** recommended to set your posts into concrete. Setting the posts in concrete will strengthen the overall fence system and increase the longevity of the fence. Alternatively, you can use expanding post foam or backfill with rocky dirt and tamp firmly.

2.

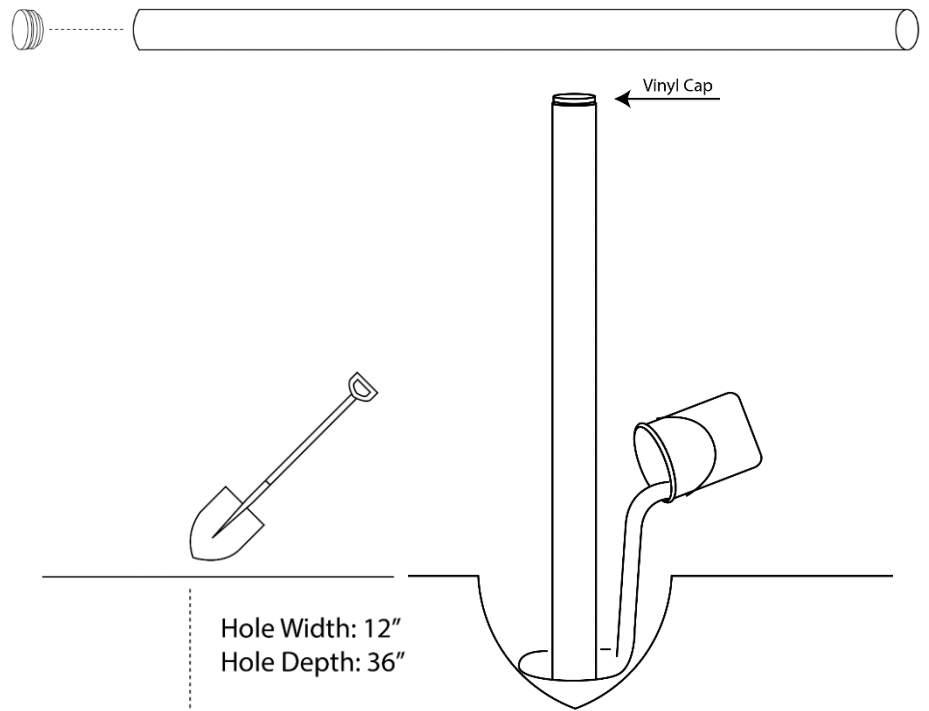

3. Slip **BRACE BAND (B)** and **BRACE CUP (A)** over the **END POST (E)** and position them approximately 12" from the top of the **END POST (E)**. When attaching the **BRACE CUP (A)** to the **BRACE BAND (B)**, position the cup so that the **BRACE POST (F)** will be on the **INSIDE** of the fence line. Use **CARRIAGE BOLT (C)** to hold the **BRACE BAND (B)** and **BRACE CUP (A)** in position. Do not fully tighten.

3.

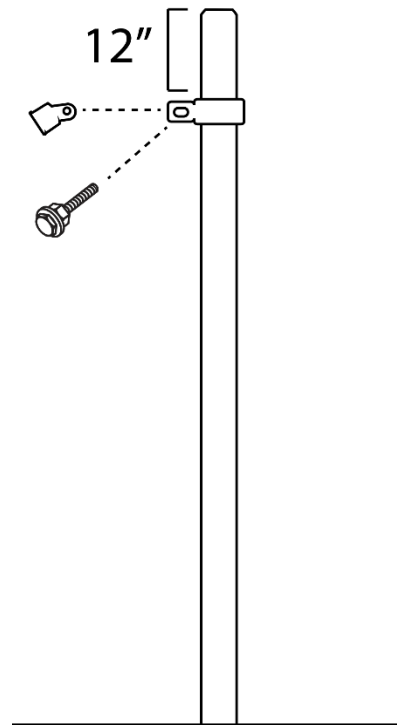

4. After the band is installed, place your **BRACE POST (F)** into the **BRACE CUP (A)** just inside the fence line. At the point where the post meets the ground, you will want to dig a hole approximately, 1' deep. Set the **BRACE POST (F)** into the hole and use a dead man brace to secure the post.

4.

Note: A dead man brace is a brace put into the ground to hold the brace post in position. You can use a cinderblock or a large sturdy piece of wood as the dead man. Alternatively, you can cement the brace post if you choose.

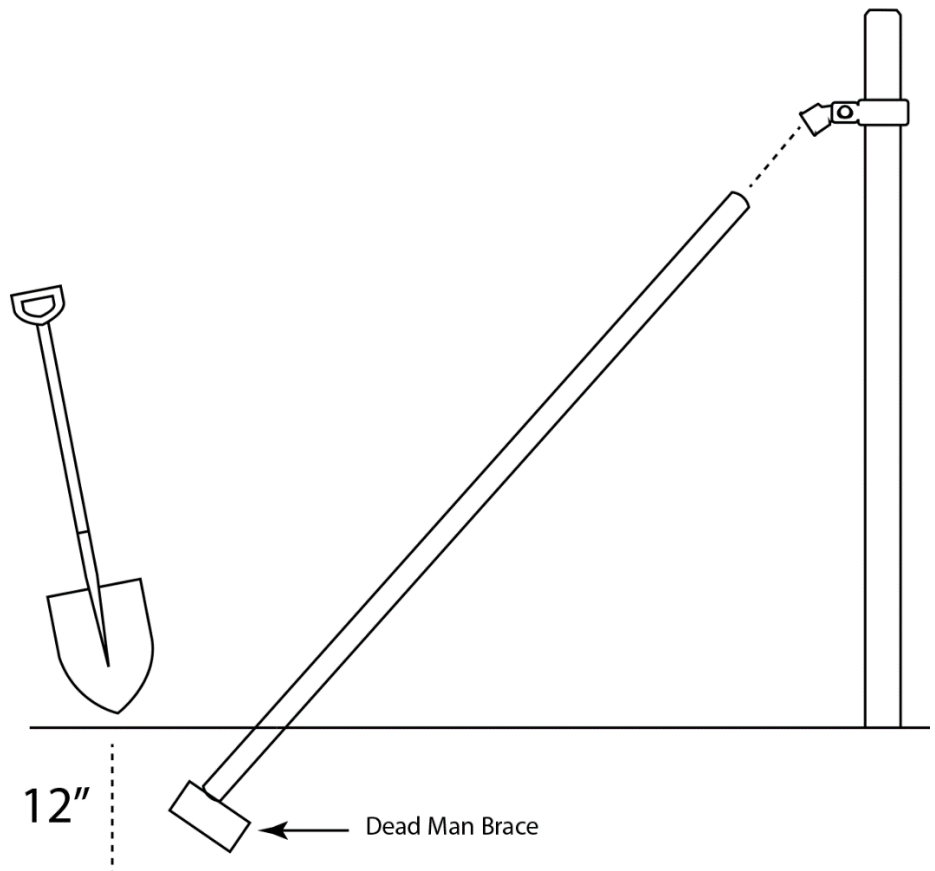

5. Once the dead man is in place, adjust your **BRACE POST (F)** so it rests tightly against the dead man. Fill the hole back up with dirt and tamp down. Secure the **BRACE POST (F)** by drilling a **SELF-TAPPING SCREW (G)** through the **BRACE CUP (A)** and **BRACE POST (F)**. Once secured, tighten the **CARRIAGE BOLT (C)** on the brace band.

5.

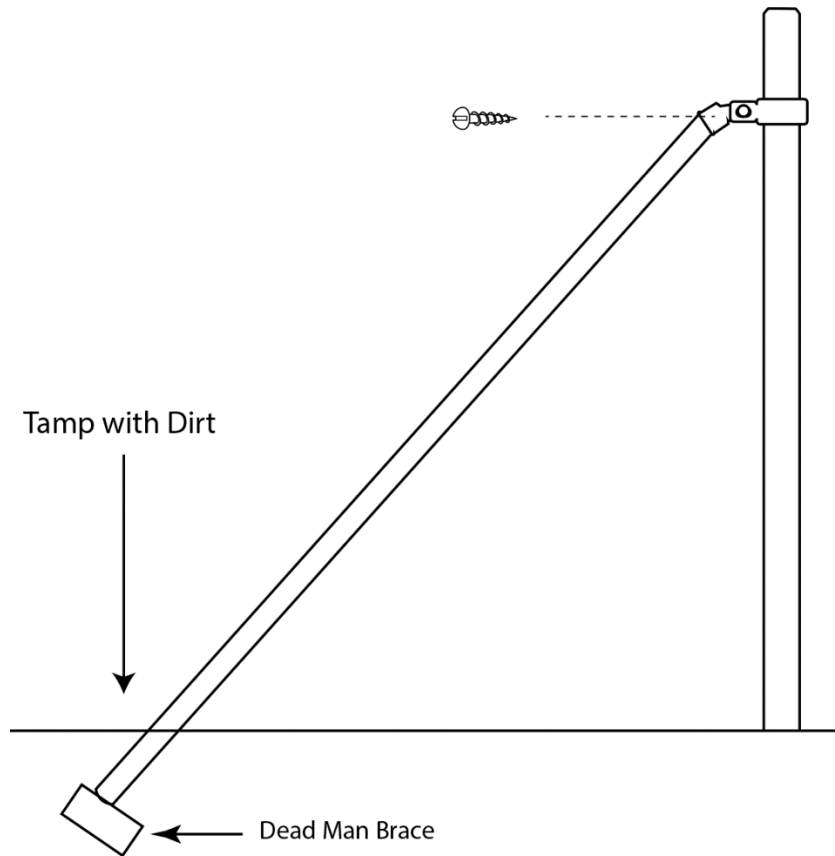

Birds Eye View

