

GENUINE 

Lifting Anchor Systems

Installation Guide

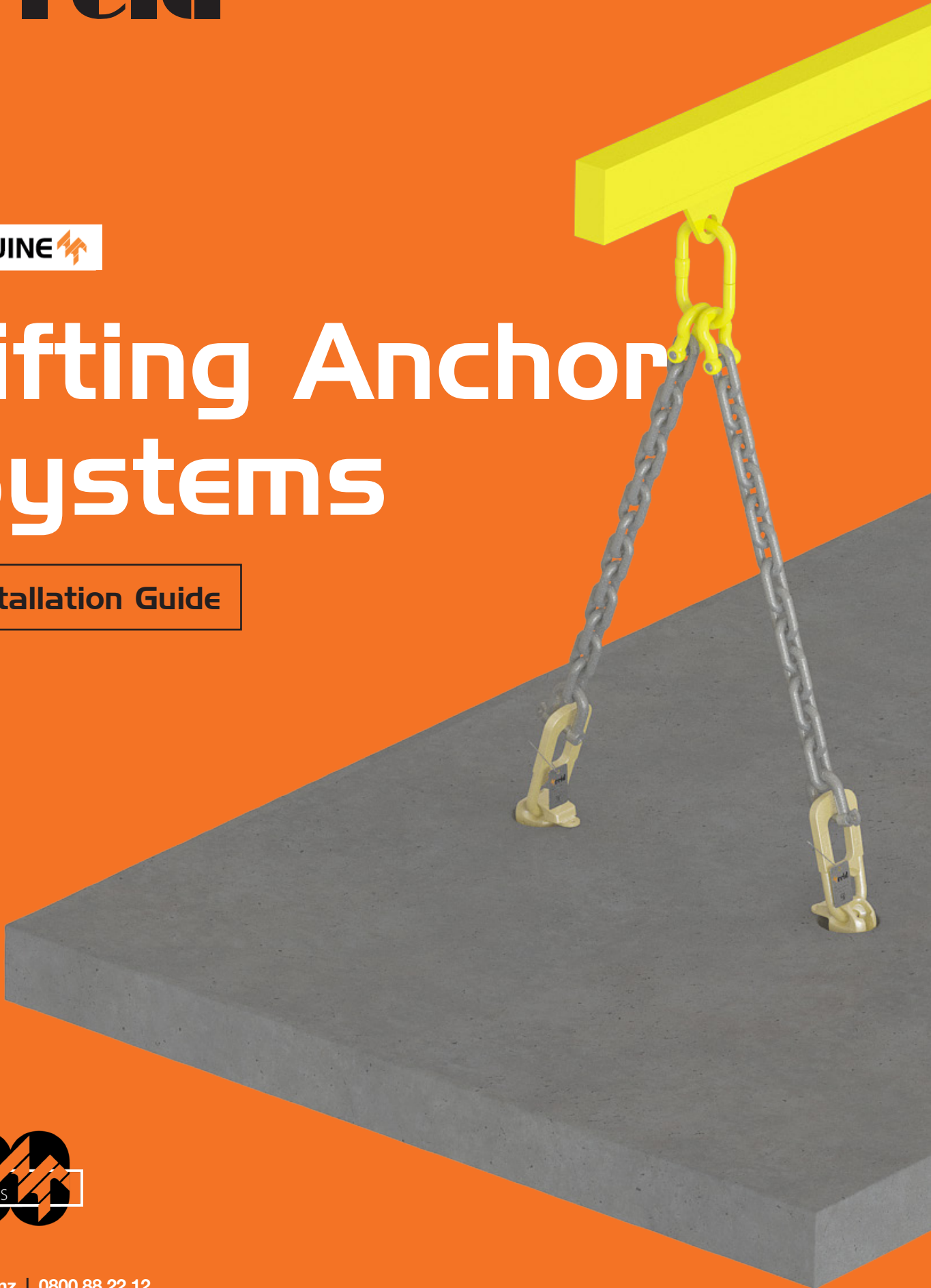



Contents

Lifting Anchor Systems	4
Before Anything	4
Types of Lifting	5
Types of Lifting Anchors	5
Flat Lifting Systems	
Flat Lift Anchors	6
Product Identification (Flat Lift Anchor)	6
Flat Lift Void Formers	7
Installation Process (Flat Lift Anchor Installation)	8
Installation Process (Flat Lift Void Removal)	9
Face Lifting Systems	
Face Lift Anchors	10
Installation Process (Face Lift Anchor Installation)	10
Face Lift Installation Process (Void Removal)	10
Product Identification (Face Lift Anchor)	11
Edge Lifting Systems	
Edge Lift Anchors	12
Product Identification	
(3Dx™ / Edge Lift Anchors with Feet)	13
Product Identification (EdgeMaster™)	14
Installation Process (Edge Lift Anchor Installation)	15
Appendix: Anchor Tolerance	
Edge Lift Anchors	16
Edge Foot Anchors	19
Edge Eye Anchors	20

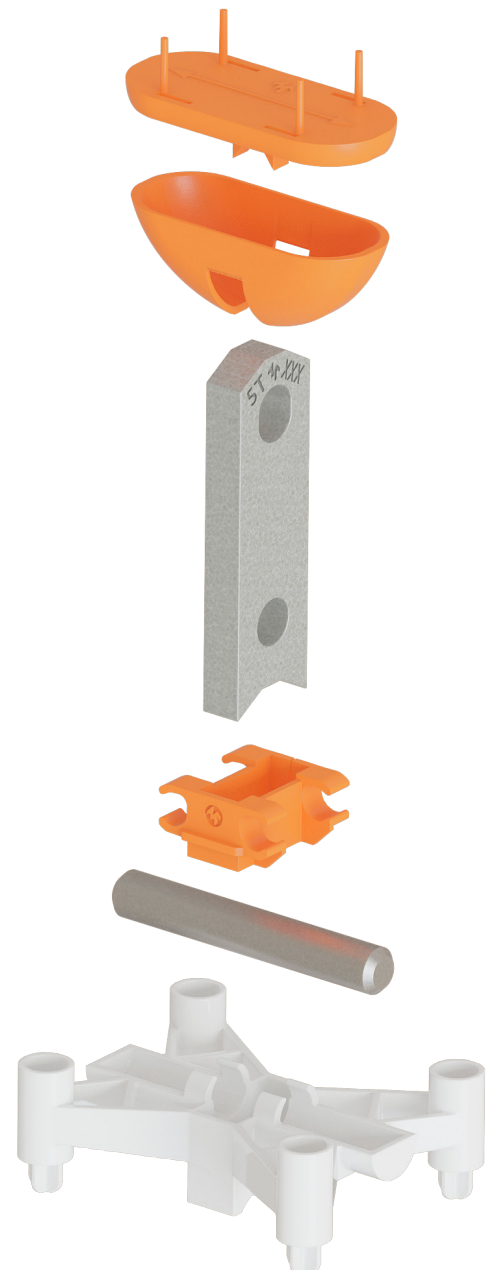

Lifting Anchor Systems

Reid™ not only has a reputation for quality but also as the longest serving supplier of Concrete Lifting Products in New Zealand. If your business is lifting precast or tiltup concrete, the range of products offered by Reid is the most comprehensive, researched and tested by any New Zealand supplier.



NZ GPG 2018
Compliant



Before Anything

1. Be aware of and follow any and all relevant standards, codes of practice and guides
2. Ensure you have all appropriate engineering drawings, including but not limited to certified lifting and bracing designs, which detail load conditions, lifting point rigging and bracing designs.
3. Carry out all lifting and bracing in accordance with certified drawings.
 - a. Any questions pertaining to the drawings must be directed to those who issued them or a suitably qualified engineer.
4. Use only qualified crane companies/operators/individuals and riggers
5. Prior to lifting identify all lifting points, clutches, etc.. are as specified in the certified drawings and are compatible (match). If any component is not as documented, the lift should not continue until reviewed and approved by a competent engineer.
6. Check proof load testing tags on clutches and ensure they are within their annual test date
7. Visually inspect clutches for any wear and tear
8. Maintain a clear/fall zone around planned lift area



WARNING: DO NOT WELD TO LIFTING ANCHORS

Note: Reid does not support welding to any anchor.

Types of Lifting



Flat (or Top) Lift:

Where the initial direction of the lift is in-line with the anchor axis. The lift puts the anchor into tension only.



Face (Shear) Lift:

Where the initial direction of the lift is perpendicular to the axis of the anchor. The lift applies a shear load only to the anchor



Edge Lift:

The initial direction of the lift is transverse to the anchor axis, putting the anchor into shear at the beginning of the lift and moves into tension as the lift is completed.



Rotational Edge Lift:

The initial lift is shared by a number of anchors (typically 3 or 4). This load puts the anchors into in-plane shear at the beginning and transitions into tension as the load is rotated for placement.

Types of Lifting Anchors

Flat Lift Anchors

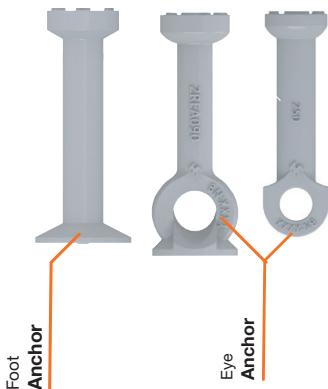

Face Lift Anchors

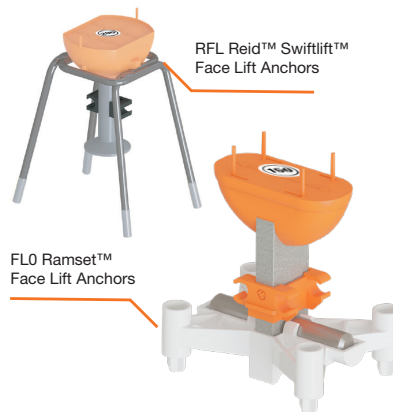

Edge Lift Anchors

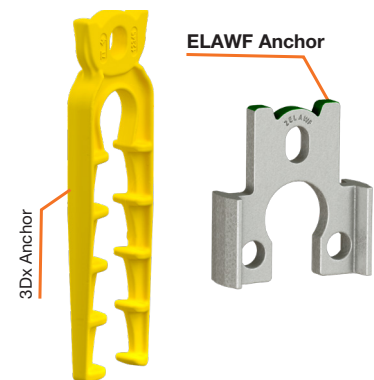

Flat Lift Anchors

These anchors are cast into the precast element with a void former, which once cast & removed, allows the clutch to engage the anchor.

They are used in a variety of elements including pits, lids, culverts, pipes, beams and planks. The type of anchors used will depend on the shape and weight of the element. Both foot and eye anchors have a load range of 1.3t – 32t WLL. It is recommended to use the longest possible anchor available in any size range as foot anchors perform by developing a “pull out cone” in the concrete. The diameter of the cone on the surface can be upto six times the depth of the anchor. The longer (deeper) the anchor, the larger cone.



SwiftLift Eye Anchors

Used with a reinforcing hanger bar they are able to provide deeper anchorage and increased load capacity in thin wall or low strength concrete elements. they allow for deeper anchorage and increased load capacity in thin wall or low strength concrete elements.

They are ideal for bridge beams and other heavy precast concrete elements.



SwiftLift Foot Anchors

Consistent with the Reid™ commitment to local testing, SwiftLift™ Foot Anchors have been extensively tested in Australian concrete comprising of over 500 individual tests, and consuming over 150 tonnes of concrete.



Product Identification

Flat Lift Anchor ID: Foot, Eye & Combination Anchor Markings

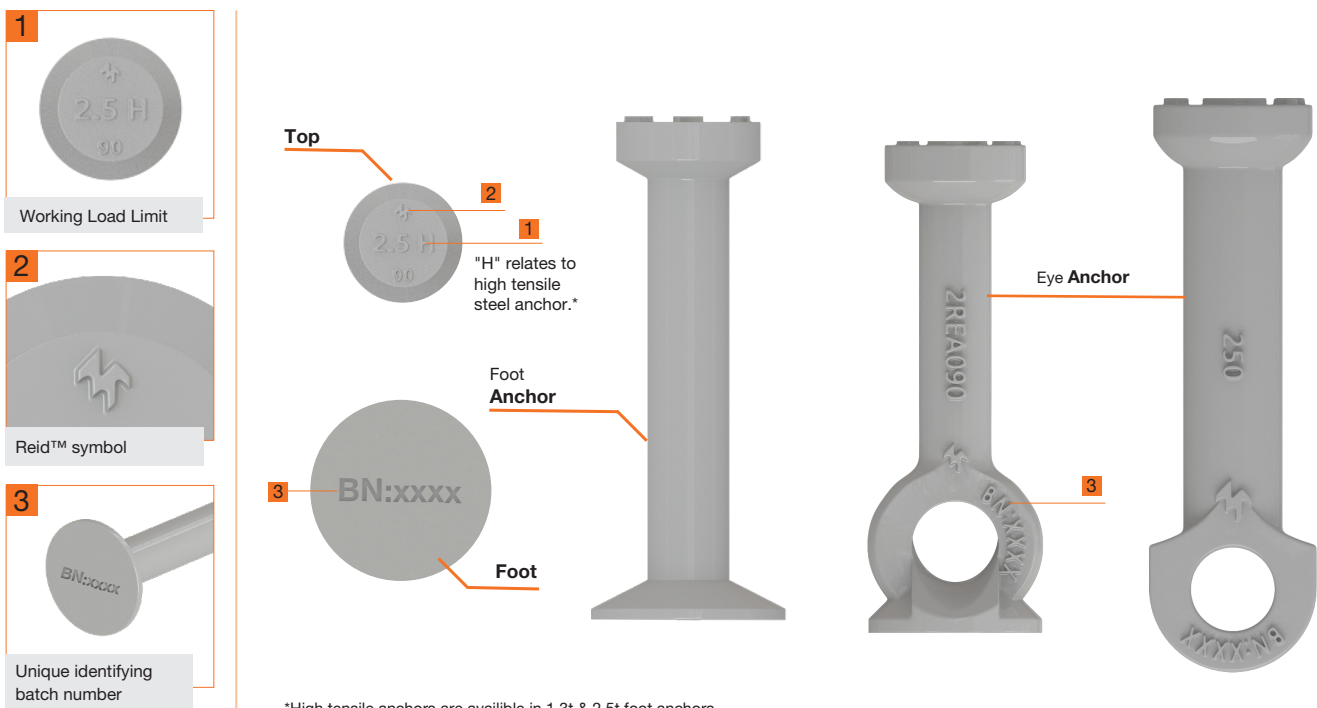

Flat Lift Void Formers



Types Of Flat Lift Void Formers

Reid SwiftLift™ foot and eye anchors can be used with a few different voids formers.

Rubber Round Void Former

- A round void former made from rubber. This produces the exact void in concrete, allowing for the clutch to engage the head of the anchor.
- Supplied with a bolt, wingnut and placards allowing to be fixed to various formwork, ensuring anchor location remains consistent.
- Rubber voids are also able to be “puddled” into wet concrete.
- Available to suit SwiftLift™ anchor sizes 1.3t -32t
- Used in situations where the anchor needs to be located on the top surface of a product (as cast)



Steel Round Void Former

- A steel round void former. This produces the exact void in concrete, allowing for the clutch to engage the head of the anchor.
- Requires rubber ring installed on anchor and fitted into void to ensure correct void development
- Has a long lifespan
- Supplied with threaded base
- Available to suit SwiftLift™ anchor sizes 1.3t-5t
- Used in situations where stripping of formwork without removing the void is required. Typically, when an anchor is inverted & located in the bottom of a product.
- weldable, where a permanent void location is required.



Steel Articulated Void Former

- Used as an alternative to rubber void former for a longer service life.
- Available in sizes to suit SwiftLift™ anchor 1.3t-5t
- Used where an anchor needs to be located in the side (anchor is horizontal) of a product (as cast)

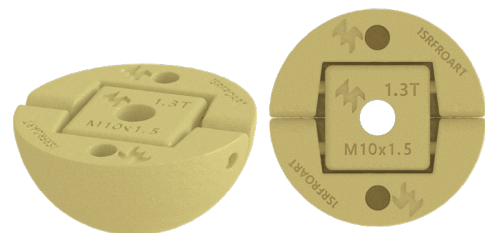

Plastic Void Former

- Designed as single use replacement for rubber void formers
- Manufactured from plastic
- Available to suit SwiftLift™ anchors 2.5t & 5t

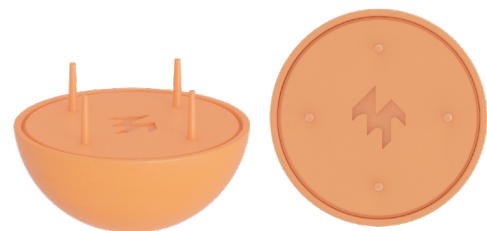

Installation Process

Flat Lift Anchor Installation Foot & Eye Anchors

Steel Round Void

1. Secure rubber ring around anchor head
2. Secure void to formwork in its required location.
3. Insert anchor with the attached rubber ring into the void



Articulated Void

1. Open void, allowing anchor to be installed.
2. Insert anchor into void
3. Close void around head of anchor
4. Secure assembled void former to formwork in its required location. Note, the void will not hold the anchor securely until the assembly has been secured.



Plastic Void

1. Remove plastic collet from void and attach to anchor head.
2. Insert anchor with attached plastic collet into the plastic void
3. Install in required location



Rubber Round Void

1. Flex the void former open, allowing the anchor to be installed.
 - a. For the most secure attachment, pass the setting bolt through the form and fasten with the wing nut.
 - b. When puddling in the anchor, hold the assembled void and anchor by the setting bolt and push into concrete until the face of the void is flush with the surface of the concrete.
3. Place anchor in location in accordance with certified drawings.
4. Vibrate concrete as per standard practices, taking care around the anchor, ensuing and vibrations around the anchor is minimized.

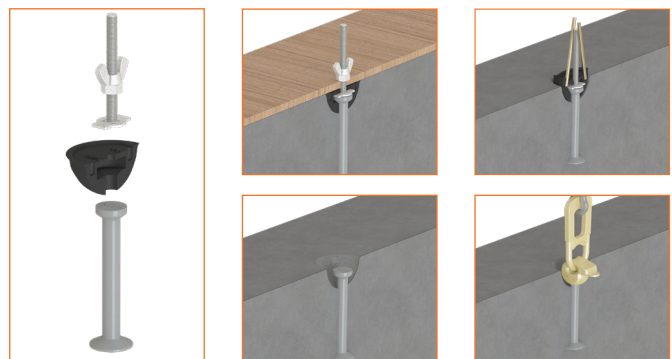

Please Note: All eye anchors require supplementary reinforcement to be installed with the anchor in order to achieve the stated WLL. For more detail refer the Reid eye anchor compliance document.

Installation Process

Flat Lift Void Removal Foot & Eye Anchors

Rubber Round & Steel Articulated Voids

1. These voids have 2 holes located in the rear of the void, allowing for rods (or similar) to be installed .
2. While rods (or similar) are inserted into the void, cross exposed ends in to a "X", leveraging the void ends and allowing it to release the anchor.



Steel Round Void

1. Undo wing nut or setting bolt
2. Remove formwork from concrete
3. Remove void from the head of anchor
4. Remove rubber ring from head of anchor

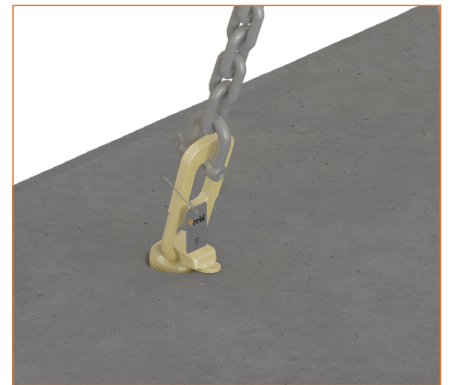

Plastic Void

1. Using a self-drilling hex head timber screw and electric drill, drill into the centre of the void
2. When the screw contacts the head of the anchor, stop drilling. Pull on screw and the void will release with ease.
3. Remove void and collet.



Face Lift Anchors

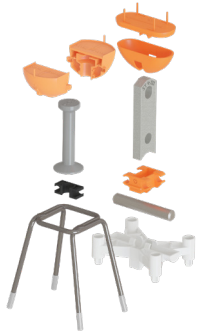

Facelifting is the practice of casting anchors into the near face (as cast) of a panel or similar precast product, allowing for rigging to be connected and product to remain in the same plain or even rotated vertically.

Reid offer 2 full assemblies in the face lift space. These are both rated at 5t WLL, the difference between the two being the clutches which engage the anchor. It is important to be aware of this as the RFL series anchors utilise the 5LE, whereas the FL050 series anchors use the 7ELALE. Both assemblies have been designed so as the clutch cannot spontaneously disengage while the system is under load.



NZ GPG 2018 Compliant



Installation Process

Face Lift Anchor Installation RFL & FLO

These anchors come preassembled in common heights (to suit various panel thicknesses); as such there is no need to select or change the void or charring. One simply determines the required location, in accordance with the approved drawings, and places the anchor. One must ensure the anchor is installed with the arrows (located on the void) pointing to the top or bottom of the panel (as placed). Incorrect installation can result in anchors not achieving full capacity. To further assist in the anchor maintaining its location over the production process, Reid™ has developed and supported the use of floating bar clips. After the anchor is placed, clip in 2 x 12mm x 300mm bars. These bars can be tied directly to adjacent reinforcement, to ensure anchors remain where placed, while the floating bar clip allows for it to still be trafficked.

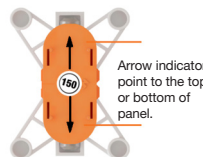
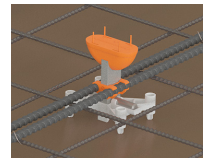

Face Lift Anchor Void Removal RFL & FLO

1. Hammer a flat head screwdriver off centre into the void.
2. Lever void to release.
3. Repeat step 1 on other side.
4. Remove void.

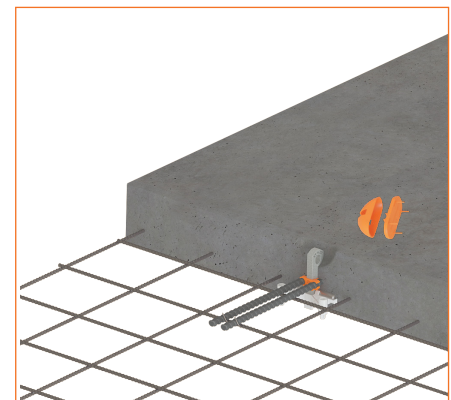
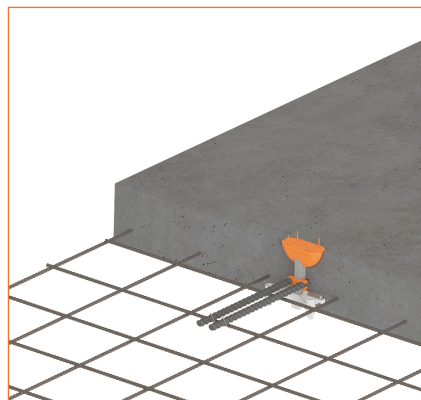

Product Identification

Face Lift Anchor ID: RFL (Reid Face Lift) series



Head Identification
(WLL, Reid Logo,
Insert Length)



Batch Number

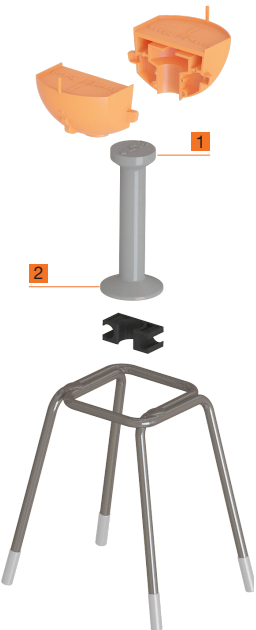
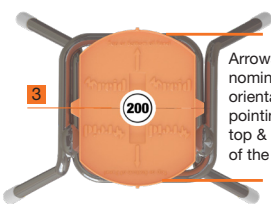

Panel Thickness

Arrows nominate orientation; pointing to the top & bottom of the panel.



Reid™ Swiftlift™
Face Lift Anchors

NOTE:
The Reid™ Face Lift Anchor must be placed as per the arrow indicators on the top of the Void Former.

Face Lift Anchor ID: FLO50 (Face lift) series

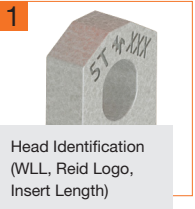

Head Identification
(WLL, Reid Logo,
Insert Length)



Batch Number

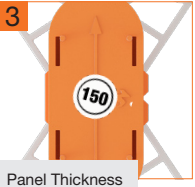

Panel Thickness

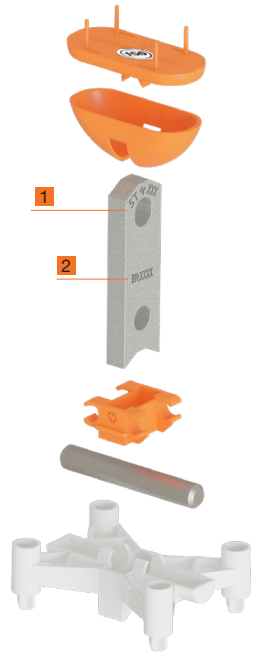
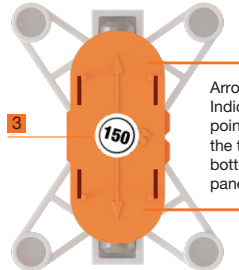



Arrow Indicators point to the top or bottom of panel.

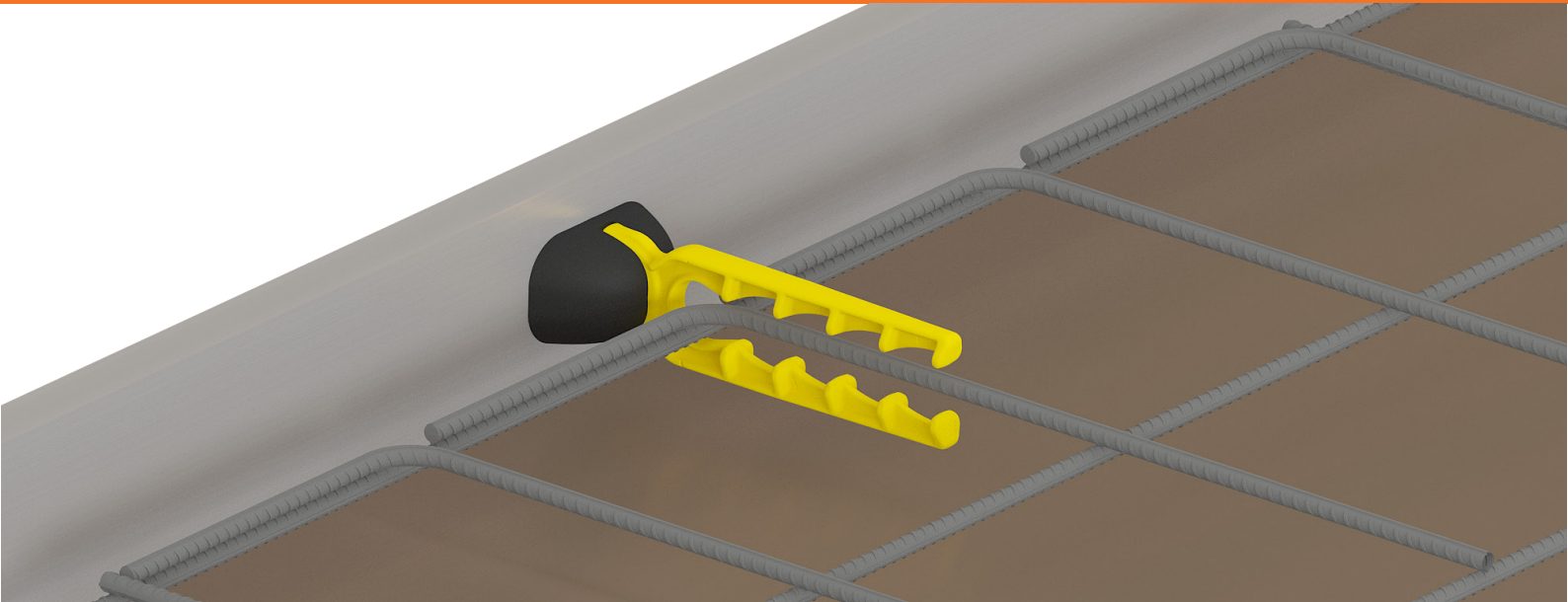

Face Lift Anchors

NOTE:
The Face Lift Anchor must be placed as per the arrow indicators on the top of the Void Former.



Edge Lift Anchors

Edgelift anchors are cast into the edge of the precast element.

By utilising this methodology, these anchors can be located in the edge of the panel, removing the need for anchors being placed on the face of the panel. This removes the need to grout on exposed faces of panels. Reid offers 3Dx, ELAWF & EdgeMaster ranges as edgelifting options. Please refer to each ranges compliance document for further information.



3Dx™ Edge Lifting System

Developed, and tested in New Zealand by Reid™, the 3DX7N Lifting System provides high lifting capacities and levels of efficiency and productivity. The unique design distributes loads in the concrete in three dimensions, maximising capacity while reducing outward bursting loads resulting in potential panel damage.



Edge Lift anchor with Feet

ELAWF have been extensively designed and used in NZ for years. Requiring supplementary reinforcement, these anchors achieve high capacity at early concrete strengths. with WLL from 2-10t this system can assist with any project.



SwiftLift™ EdgeMaster™ Edge Lift Anchor System

This assembly consists of a foot anchor along with an integrated shear bar and void former, making it an economical solution for on site panel production. SwiftLift™ EdgeMaster™ have been extensively tested in concrete.



Product Identification

Edge Lift Anchor ID: Reid™ 3Dx™ Edge Lift Anchors

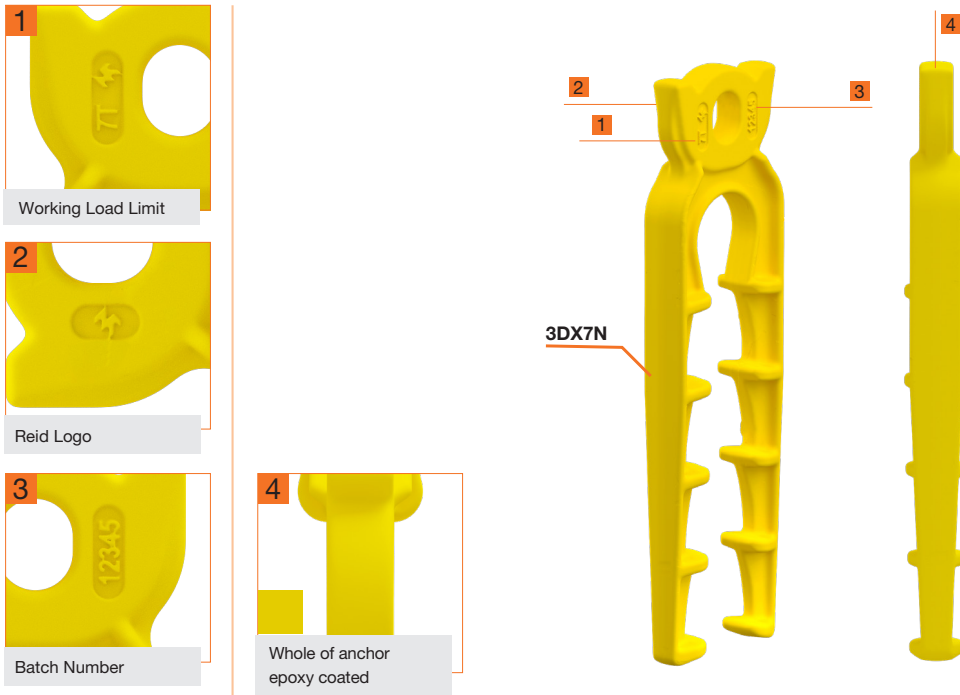

Edge Lift Anchor ID: Reid™ Edge Lift Anchor ELAWF

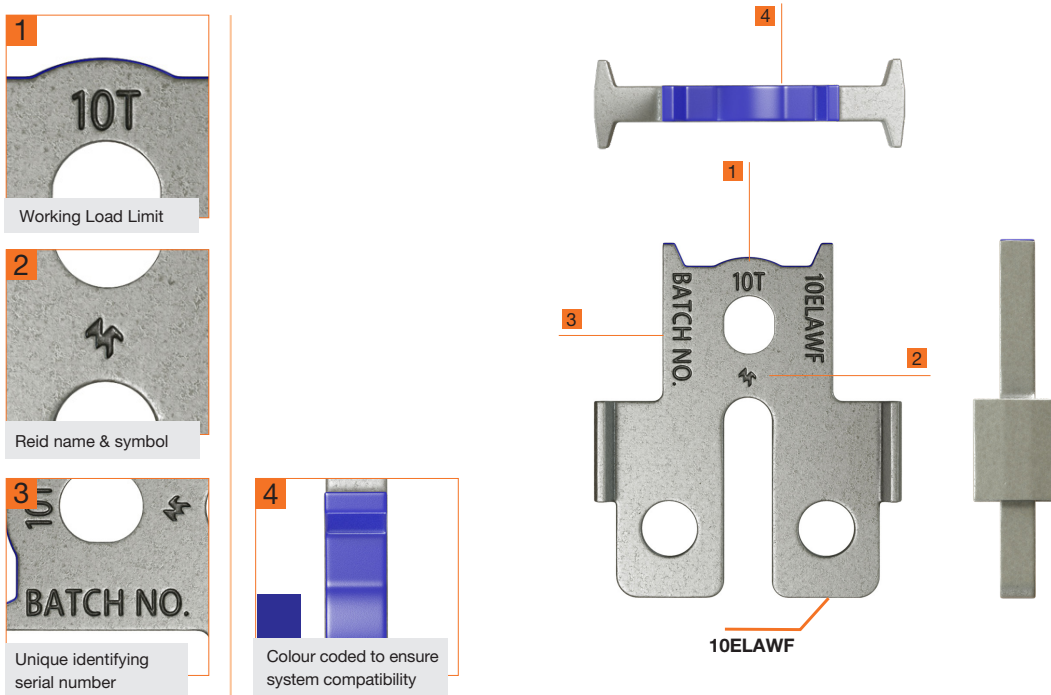

Product Identification

Edge Lift Anchor ID: Reid™ EdgeMaster™ and Foot Anchor Markings

1



Working Load Limit

2



Reid™ symbol

3



Unique identifying batch number

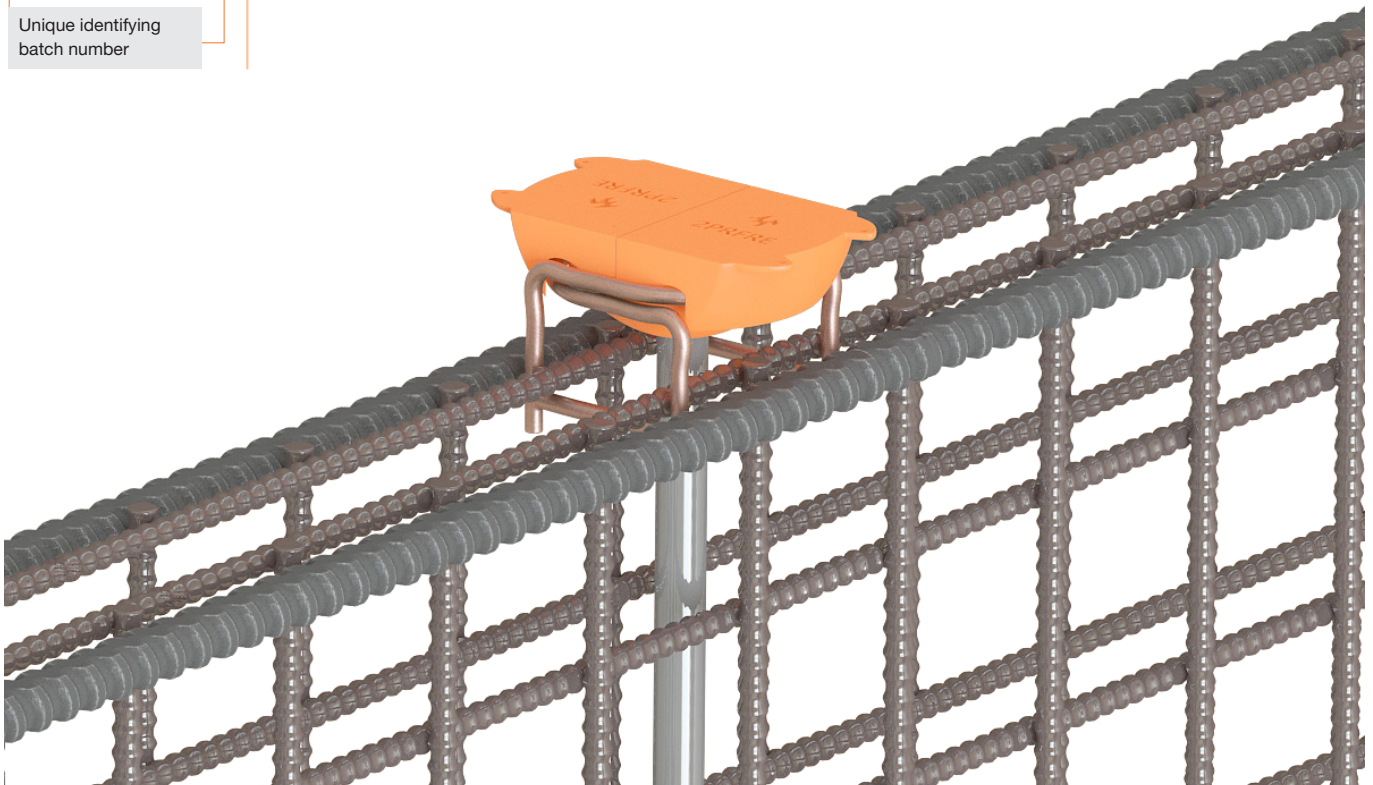
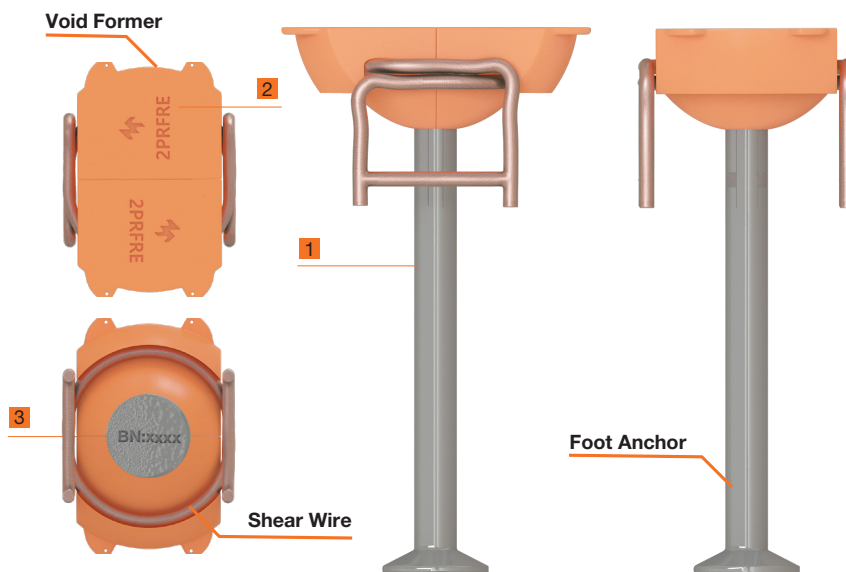

Installation Process

Edge Lift Anchor Installation 3Dx™, ELAWF & EdgeMaster™

3Dx™



Edge Lift Anchor Installation 3Dx™ & ELAWF

- Select the appropriate void based on anchor being use. Refer anchor compliance document for further info.
- Flex open void to allow for anchor installation
- Place anchor into void former
- Insert void support place into back of void, if tying anchor into place. Alternatively, the support plate can be fixed to the formwork and the void/anchor assembly can be placed onto the support plate.
- Locate & place anchor into nominate location, in accordance with approved drawings.
- 3Dx & ELAWF anchors are not reliant on specific perimeter bar location, as such, they can be placed on the near face or in between the anchor legs.
- Install anchor with central mesh and perimeter bar between anchor legs when single layer reinforcement is being used.

Add supplementary anchor reinforcement as follow;

- Tension bar (3Dx and ELAWF)

These bars should be tied to the anchor only. Reid does not support the practice of welding to any anchor. Refer compliance doc for further information on bar sizes and locations

ELAWF

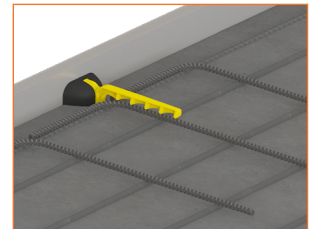
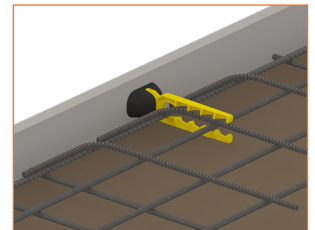

Example of 3Dx™ Installation

EdgeMaster™



Edge Lift Anchor Installation EdgeMaster™

This anchor uses a plastic Void Former, SwiftLift™ Foot Anchor and an EdgeLift™ Bracket in its assembly. It is sold pre-assembled and ready for install. Edgemaster contains 4 locating holes and can be fixed to the form via nailing or with double sided tape.

Void Removal 3Dx™, ELAWF & EdgeMaster™

Void Removal

1. Remove formwork from precast element
2. The voids have 2 holes located in the rear of the void, allowing for rods (or similar) to be installed.
3. While rods (or similar) are inserted into the void, cross exposed ends in to a "X", leveraging the void ends and allowing it to release the anchor.

Edgemaster Void Removal

1. Hammer a flat head screwdriver off centre into the void.
2. Lever void to release.
3. Repeat step 1 on other side.
4. Remove void.

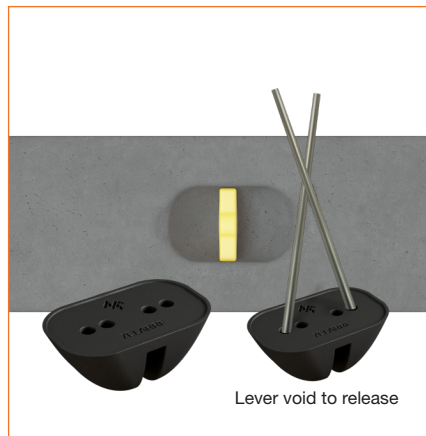

Anchor Tolerance

Allowable tolerance for Edge Lifters Perpendicular to Precast Face

Anchor Type	Allowable Tolerance
3DX7N	+/- 5mm *

* for thicknesses less the 150mm allowable tolerance must be taken as +/- 2.5mm

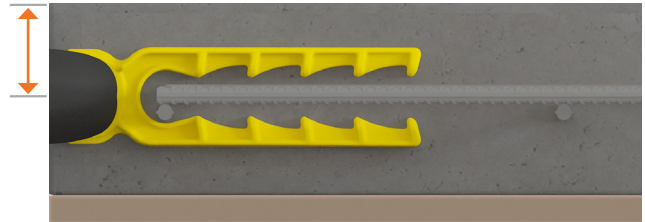

Allowable tolerance for Edge Lifters Parallel to Precast Face

Anchor Type	Allowable Tolerance*
3DX7N	+/- 20mm

* edge and spacing distance must not go below minimum requirements

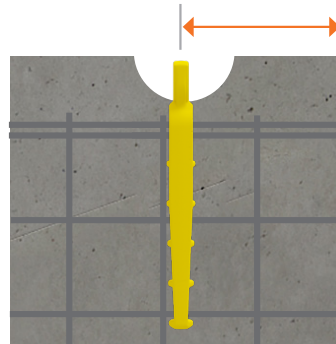

Allowable tolerance for Edge Lifters Angle

Anchor Type	Allowable Tolerance
3DX7N	+/- 5 degrees

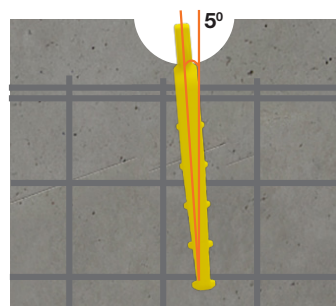

Minimum and Maximum Depth of Edge Lifters

Anchor Type	B Max (mm)	B Min (mm)
3DX7N	8.2	2.1

Note measurement should be taken at the highest point of lifting anchor head



Anchor Tolerance

Allowable tolerance for Edge Lifters Perpendicular to Precast Face

Anchor Type	Allowable Tolerance
2ELAWF	+/- 5mm *
7ELAWF	+/- 5mm *
10ELAWF	+/- 5mm

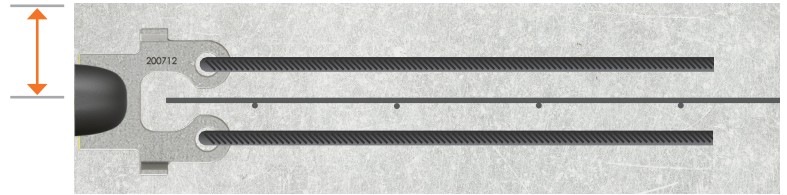

* for thicknesses less than 150mm allowable tolerance must be taken as +/- 2.5mm

Allowable tolerance for Edge Lifters Parallel to Precast Face

Anchor Type	Allowable Tolerance*
2ELAWF	+/- 20mm
7ELAWF	+/- 20mm
10ELAWF	+/- 20mm

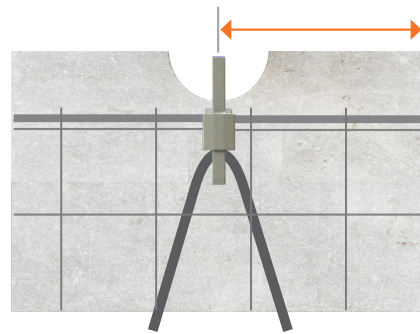

* edge and spacing distance must not go below minimum requirements

Allowable tolerance for Edge Lifters Angle

Anchor Type	Allowable Tolerance
2ELAWF	+/- 5 degrees
7ELAWF	+/- 5 degrees
10ELAWF	+/- 5 degrees

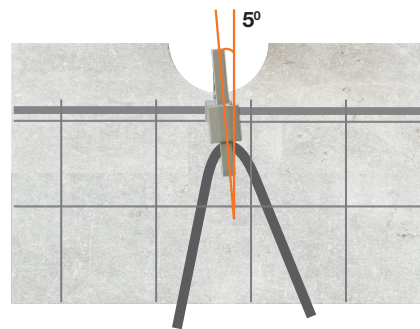

Minimum and Maximum Depth of Edge Lifters

Anchor Type	B Max (mm)	B Min (mm)
2ELAWF	9.7	3.7
7ELAWF	8.0	1.6
10ELAWF	10.9	0

Note measurement should be taken at the highest point of lifting anchor head

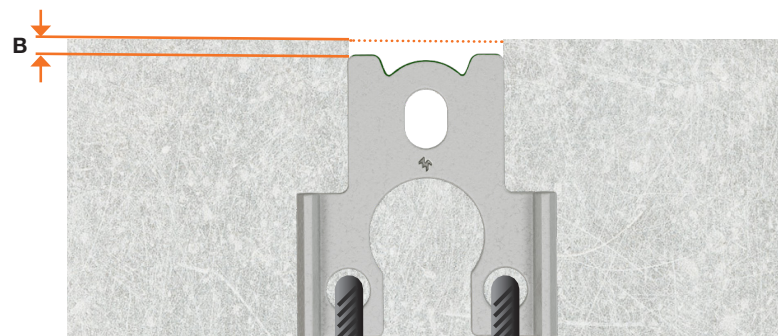

Anchor Tolerance

Allowable tolerance for Edge Lifters Perpendicular to Precast Face

Anchor Type	Allowable Tolerance
2HPAWFP	+/- 5mm *
7HPAWFP	+/- 5mm *

* for thicknesses less the 150mm allowable tolerance must be taken as +/- 2.5mm



Allowable tolerance for Edge Lifters Parallel to Precast Face

Anchor Type	Allowable Tolerance*
2HPAWFP	+/- 20mm
7HPAWFP	+/- 20mm

* edge and spacing distance must not go below minimum requirements

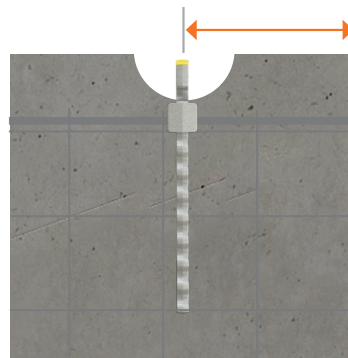

Allowable tolerance for Edge Lifters Angle

Anchor Type	Allowable Tolerance
2HPAWFP	+/- 5 degrees
7HPAWFP	+/- 5 degrees

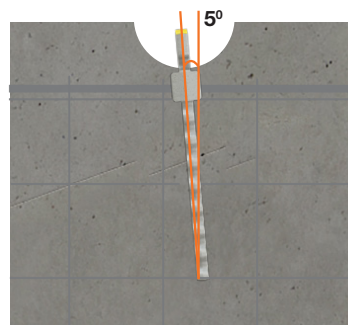

Minimum and Maximum Depth of Edge Lifters

Anchor Type	B Max (mm)	B Min (mm)
2HPAWFP	9.7	3.7
7HPAWFP	8.0	1.6

Note measurement should be taken at the highest point of lifting anchor head

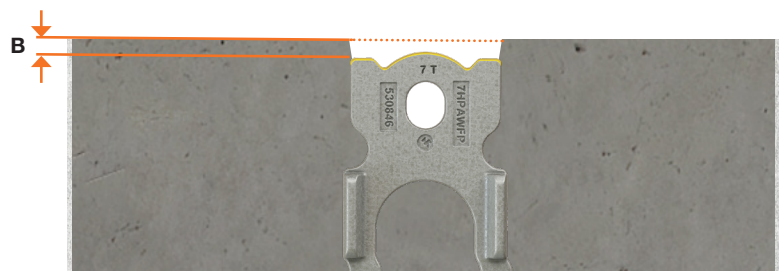

Anchor Tolerance

Allowable tolerance for SwiftLift Lifters in X & Y direction and Angular Tolerance

Anchor Type	Allowable Tolerance
1FA	+/- 20mm
2FA	+/- 20mm
5FA	+/- 20mm
10FA	+/- 20mm
20FA	+/- 20mm
32FA	+/- 20mm

Part No.	Angular Tolerance
1FA - 32FA	+/- 5 degrees

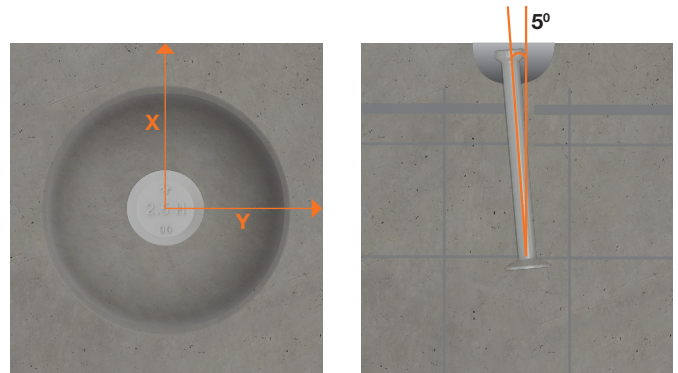

* edge and spacing distance must not go below minimum requirements stated in table 4b, table 5a and table 5b

Minimum and Maximum Depth of Reid™ SwiftLift™ Rubber Recess Formers

Part No.	B Max (mm)	B Min (mm)
1RFRO	14.6	5.0
2RFRO	15.6	6.8
5RFRO	17.7	9.3
10RFRO	15.6	9.9
20RFRO	32.5	17.0
32RFRO	30.4	18.3

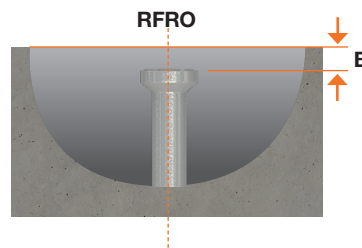

Depth Tolerance of Reid™ SwiftLift™ Steel Recess Formers

Part No.	Rubber Ring	B Min (mm)
1SRFRO	1RR	5 +/- 0.1
2SRFRO	2RR	7 +/- 0.1
5SRFRO	5RR	10 +/- 0.2

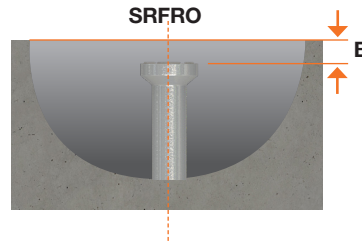

Depth Tolerance of Reid™ SwiftLift™ Steel Articulated Recess Formers

Part No.	B Max (mm)	B Min (mm)
1SRFROART	12.3	9.8
2SRFROART	13.2	9.8
5SRFROART	16.2	12.8

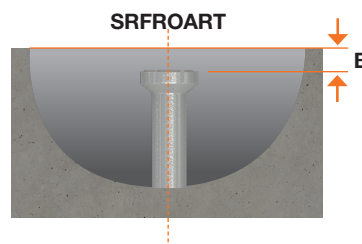

Anchor Tolerance

Allowable tolerance for SwiftLift Lifters in X & Y direction and Angular Tolerance

Anchor Type	Allowable Tolerance*
1REA	+/- 20mm
2REA	+/- 20mm
5REA	+/- 20mm
10REA	+/- 20mm
20REA	+/- 20mm

Part No.	Angular Tolerance
10REA - 20EA	+/- 5 degrees

* edge and spacing distance must not go below minimum requirements stated in table 4

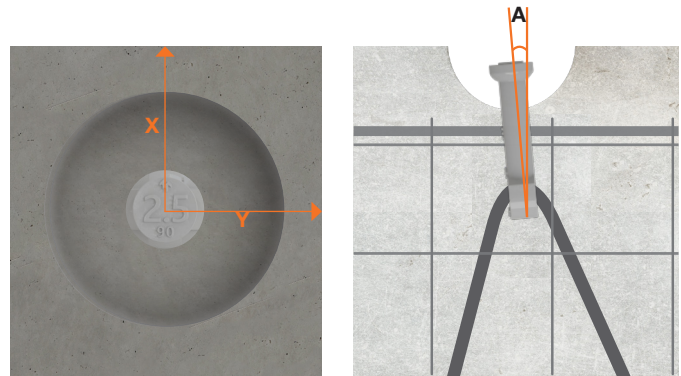

Minimum and Maximum Depth of Reid™ SwiftLift™ Rubber Recess Formers

Part No.	B Max (mm)	B Min (mm)
1RFRO	14.6	5.0
2RFRO	15.6	6.8
5RFRO	17.7	9.3
10RFRO	15.6	9.9
20RFRO	32.5	17.0

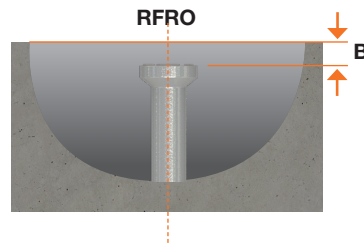

Depth Tolerance of Reid™ SwiftLift™ Steel Recess Formers

Part No.	Rubber Ring	B Min (mm)
1SRFRO	1RR	5 +/- 0.1
2SRFRO	2RR	7 +/- 0.1
5SRFRO	5RR	10 +/- 0.2

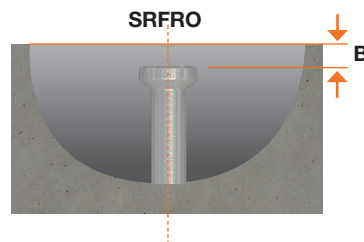

Depth Tolerance of Reid™ SwiftLift™ Steel Articulated Recess Formers

Part No.	B Max (mm)	B Min (mm)
1SRFROART	12.3	9.8
2SRFROART	13.2	9.8
5SRFROART	16.2	12.8

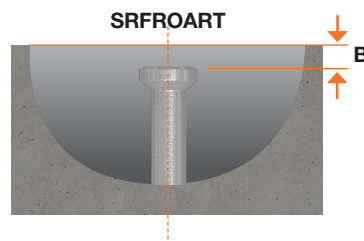



Customer Service

Reid™ Australia

Tel: 1300 780 250

Email: sales@itwcsanz.com

Web: www.reid.com.au

Reid™ New Zealand

Tel: 0800 88 22 12

Email: sales@ramsetreid.co.nz

Web: www.reids.co.nz

Reid™ Construction Systems (RCS)

AUS: 1 Ramset Drive, Chirnside Park, Victoria, Australia, 3116

NZ: 23-29 Poland Road, Glenfield, Auckland 0632

Information in this document is correct at the time of printing. Readers should contact RCS or consult RCS detailed technical information to ensure product is suitable for intended use prior to purchase. ITW Australia Pty Ltd ABN 63 004 235 063 trading as RCS © copyright 2024™ Trademarks of Cetram Pty. Ltd. Used under license by RCS

Important Disclaimer: Any engineering information or advice ("Information") provided by RCS in this document is issued in accordance with a prescribed standard, published performance data or design software. It is the responsibility of the user to obtain its own independent engineering (or other) advice to assess the suitability of the Information for its own requirements. To the extent permitted by law, RCS will not be liable to the recipient or any third party for any direct or indirect loss or liability arising out of, or in connection with, the Information. None of the products listed in this document are subject to a warning or ban under the Building Act 2004.

