

# we:boost

## Installation Guide

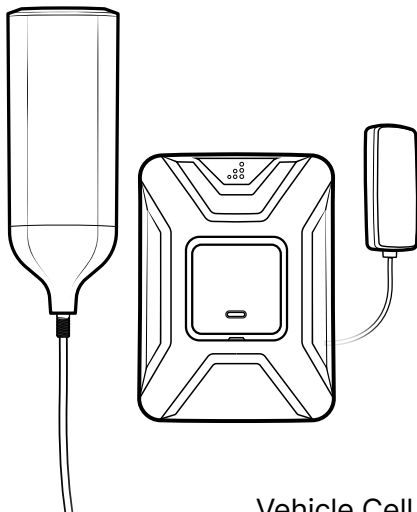

### **Drive X OTR** Vehicle Cell Signal Booster Kit

Use our **weBoost App** to guide you through the installation. See inside page for more details.

## Download the weBoost App

Use our app to guide you through setting up a weBoost cell phone signal booster in your home, business, or vehicle. Boost every network, including 5G, right away.



# Index

Package Contents . . . . .	1
Installation Overview . . . . .	2
STEP 1 Select Mounting Location & Assemble the Outside Antenna . . . . .	4
STEP 2 Mounting the Outside Antenna . . . . .	6
STEP 3 Mounting the Inside Antenna . . . . .	7
STEP 4 Connect Outside Antenna Cable to Booster . . . . .	8
STEP 5 Connect Power Supply to Booster . . . . .	10
Booster Light Patterns . . . . .	12
Troubleshooting . . . . .	14
Safety Guidelines . . . . .	16
Antenna Info . . . . .	18
Specifications . . . . .	19
Warranty . . . . .	20

## Package Contents



Drive X OTR  
Booster  
& Bracket



Outside  
Antenna



In-Vehicle  
Antenna



Power  
Supply

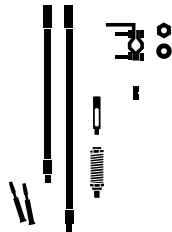

13 in. & 18 in.  
Mast Extensions,  
Side-Exit Adapter,  
Spring, 3-Way Mount,  
Cable Adapter &  
Thread Lock Packs



## Installation Overview

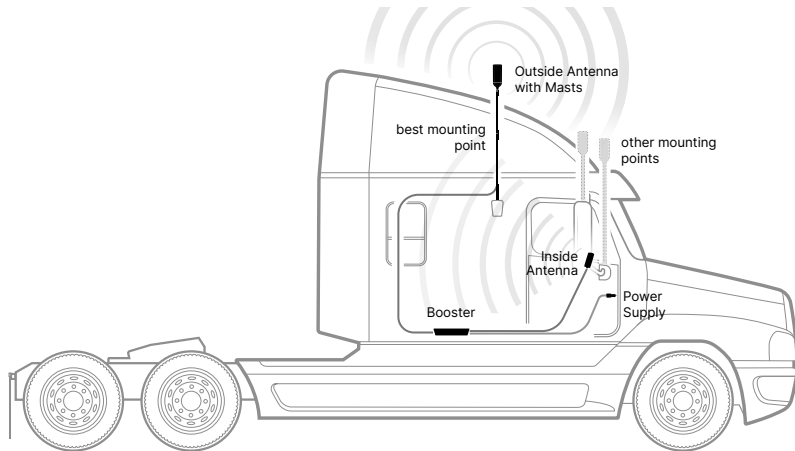

WORKS WITH DIFFERENT VEHICLE TYPES SUCH AS; SEMIS, SPRINTER VANS & PICKUPS

Depending on the type of truck, there may be built-in antenna mounting points. If the vehicle does not have built-in mounting points, the antenna includes a three-way mount that will work on vehicles with mirror rails. The antenna will also work with third party CB antenna mounts.

## Best Outside Antenna Position on other Vehicle Types

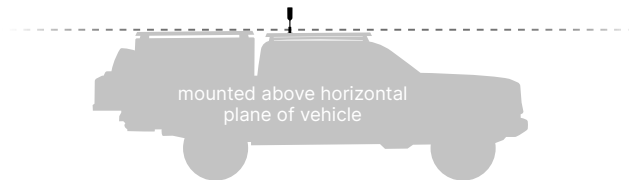

For best performance the outside antenna should be mounted above the horizontal plane of the vehicle and/or above other gear on top of the vehicle.

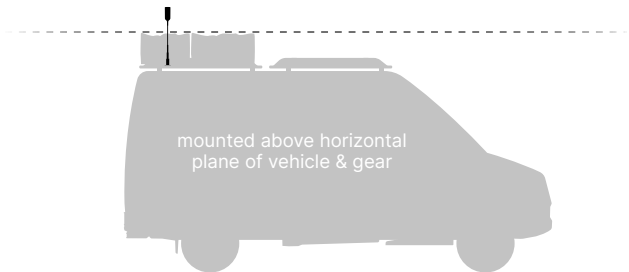

## STEP 1 Select Mounting Location & Assemble the Outside Antenna

The antenna should be mounted above gear on top of the vehicle. Once you have determined the best location for the outside antenna, **insert coax cable through mast extension (mast can be used optionally), then through side-exit adapter.**

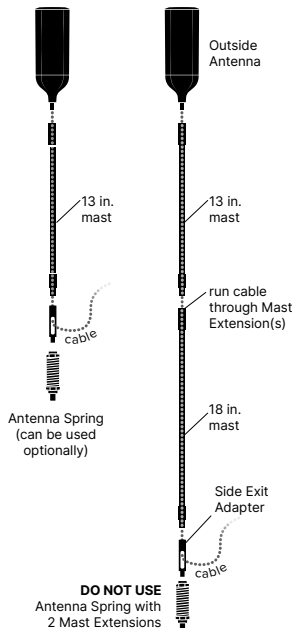
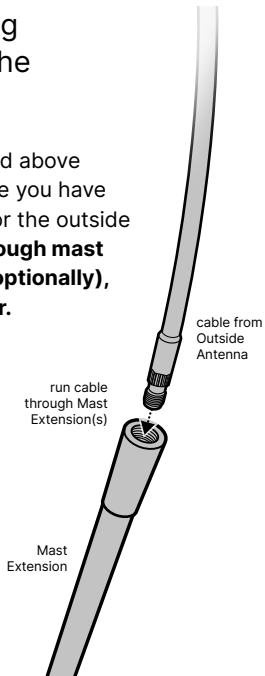

## (STEP 1 cont.)

After determining outside antenna mounting location and assembly is the correct height, **apply the thread locker** precisely to thread points only (not plastic body of antenna).

**Screw mast onto antenna.**

**Connect 16-foot cable to outside antenna cable.** Heat shrink tube can be applied to the connection (optional).

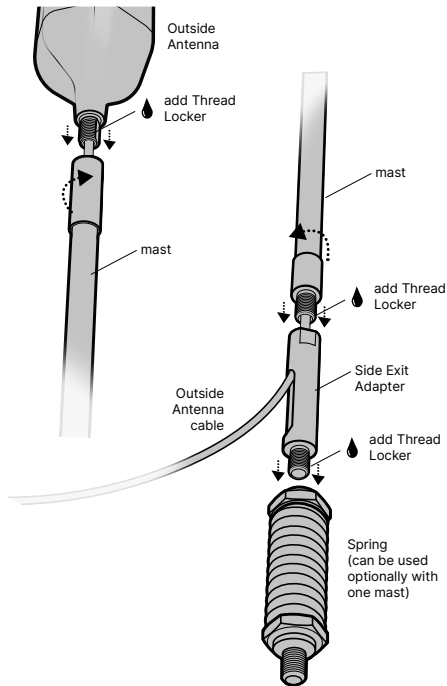

## STEP 2 Mounting the Outside Antenna

If the vehicle does not have built-in mounting points, a **3-way mount** is included that will work on vehicles with mirror rails.

NOTE: The cable is strong enough that it may be shut in most vehicle doors without damaging the cable.

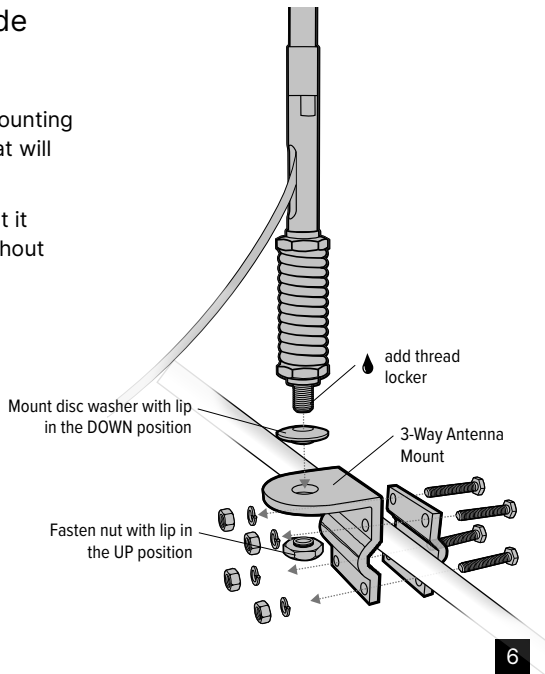

### STEP 3 Mounting the Inside Antenna

Identify a place to mount the in-vehicle antenna, either on the dash or side of the seat and mount. The location should be at least 18 inches but no more than 36 inches from where the cellular device will be used. Use the Velcro® strips provided and attach to desired location.

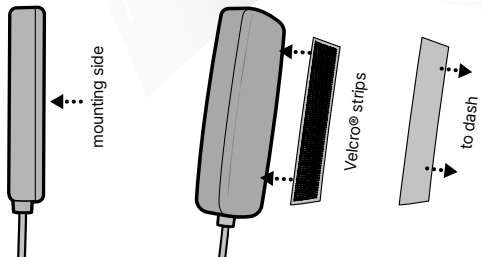

## STEP 4 Connect Outside Antenna Cable to Booster

Connect the cable from the outside antenna to the port labeled "Outside Antenna" on the booster.

NOTE: Bracket can be used to fasten booster in a specific location if desired.

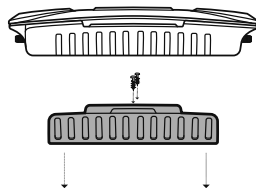
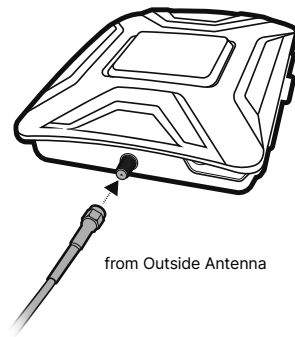

## (STEP 4 cont.)

Connect the cable from the in-vehicle antenna to the port labeled "Inside Antenna" on the booster.

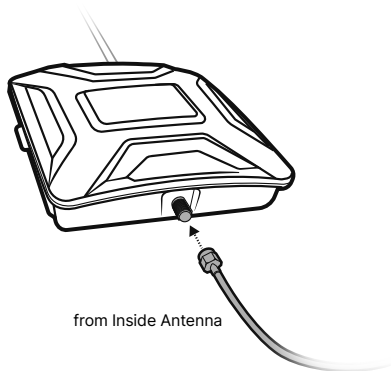



## **STEP 5** Connect Power Supply to Booster

Connect the power supply cord to the end of the booster, labeled "Power".

**NOTE:** Do NOT connect the power to the signal booster until you have connected both the inside and outside antennas.

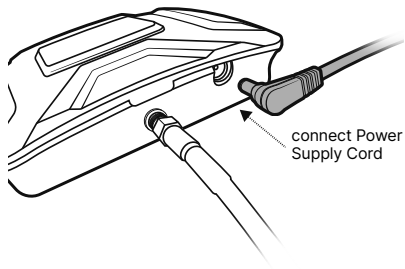

## (STEP 5 cont.)

Plug the power adapter into vehicle's 12V DC power supply. Power up your Drive X OTR by flipping the switch on the back of the DC power adapter on and watch your signal increase!

NOTE: If your Drive X OTR is working correctly, the light on the power adapter will be red, and the light on the booster will be green.

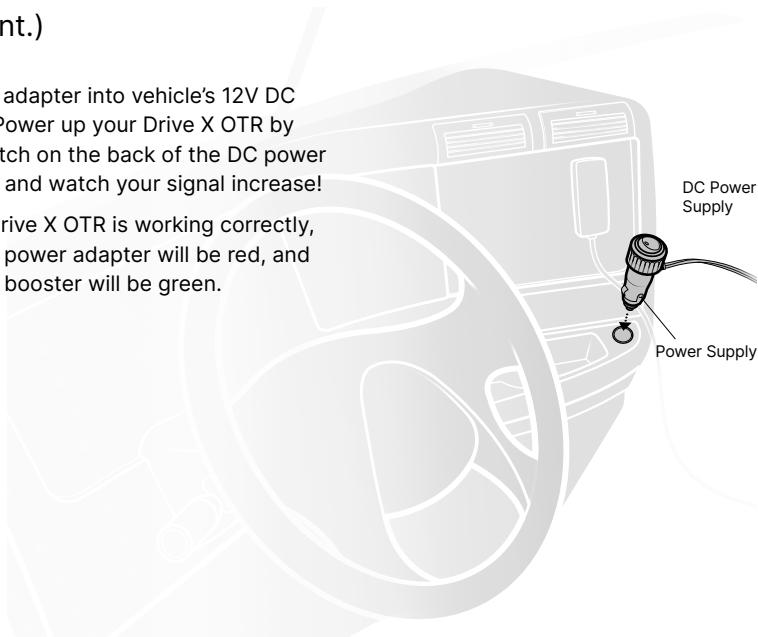

## Booster Light Patterns

### SOLID GREEN

This indicates that your Drive X OTR booster is functioning properly and there are no issues with installation.

### SOLID RED

Band has shutoff. This is due to a feedback loop condition called oscillation. This is a built in safety feature that causes a band to shut off to prevent harmful interference with a nearby cell tower. Refer to Troubleshooting section.

### BLINKING RED, THEN SOLID GREEN

This indicates that one or more of the booster bands has reduced power due to a minor feedback loop condition called oscillation. This is a built in safety feature to prevent harmful interference with a nearby cell tower. If you are already experiencing the desired signal boost, then no further adjustments are necessary. If you are not experiencing the desired boost in coverage then refer to the Troubleshooting section.

### LIGHT OFF

If the Drive X OTR signal booster's light is off, verify your power supply has power.

## (Booster Light Patterns cont.)

NOTE: The signal booster can be reset by disconnecting and reconnecting the power supply.

After troubleshooting, you must initiate a new power cycle by disconnecting and then reconnecting power to the booster.

# Troubleshooting

## FIXING BLINKING OR RED LIGHT ISSUES

**This section is only applicable if the light on the booster is red or blinking red and you are not experiencing the desired signal boost.**

- 1 Unplug the booster's power supply.
- 2 Relocate the inside and outside antenna further from each other. The objective is to increase the separation distance between them, so that they will not create this feedback condition discussed before.
- 3 Plug power supply back in and ensure switch is in ON position.
- 4 Monitor the indicator light on your booster. If, after a few seconds of 'power on', a solid or blinking red light appears, repeat steps 1 through 3. Increase the separation distance until the condition is corrected and/or desired coverage area is achieved.  
Note: Horizontal separation of the two antennas typically requires a shorter separation distance than vertical separation.

If you are having any difficulties while testing or installing your booster, contact our weBoost Customer Support team for assistance (1-866-294-1660).

## (Troubleshooting cont.)

### FREQUENTLY ASKED QUESTIONS

#### **How can I contact customer support?**

Customer Support can be reached Monday through Friday by calling 1-866-294-1660, or through our support site at [support.weboost.com](http://support.weboost.com).

#### **Why do I need to create distance between the outside antenna and inside antenna?**

Antennas connected to a booster create spheres of signal. When these spheres overlap, a condition called oscillation occurs. Oscillation can be thought of as noise, which causes the booster to scale down its power or shut down to prevent damage. The best way to keep these spheres of signal from overlapping is to maximize separation between the inside and outside antennas.

---

 1-866-294-1660

 [www.weboost.com](http://www.weboost.com)

 [support@weboost.com](mailto:support@weboost.com)

---

## Safety Guidelines

Use only the power supply provided in this package. Use of a non-weBoost product may damage your equipment.

The Signal Booster unit is designed for use in an indoor, temperature-controlled environment (less than 150 degrees Fahrenheit). It is not intended for use in attics or similar locations subject to temperatures in excess of that range.

All inside panel and dome antennas must have at least 6' of separation distance from all active users, and low profile antennas must have at least 1.5' separation distance from all active users.

Connecting the Signal Booster directly to the cell phone with use of an adapter will damage the cell phone.

RF Safety Warning: Any antenna used with this device must be located at least 8 inches from all persons.

### **This is a CONSUMER device.**

---

**BEFORE USE**, you **MUST REGISTER THIS DEVICE** with your wireless provider and have your provider's consent. Most wireless providers consent to the use of signal boosters. Some providers may not consent to the use of this device on their network. If you are unsure, contact your provider.

In Canada, **BEFORE USE** you must meet all requirements set out in ISED CPC-2-1-05.

You **MUST** operate this device with approved antennas and cables as specified by the manufacturer. Antennas **MUST** be installed at least 20 cm (8 inches) from (i.e., **MUST NOT** be installed within 20 cm of) any person.

You **MUST** cease operating this device immediately if requested by the FCC (or ISED in Canada) or licensed wireless service provider.

**WARNING.** E911 location information may not be provided or may be inaccurate for calls served by using this device.

(Safety Guidelines cont.)

**FOR MORE INFORMATION ON REGISTERING YOUR SIGNAL BOOSTER WITH YOUR WIRELESS PROVIDER IN THE U.S., PLEASE GO TO THE LINK BELOW:**

<https://www.weboost.com/carrier-registration>



## Antenna Info

The following accessories are certified by the FCC to be used with the Drive X OTR Booster.

This radio transmitter 4726A-460021 has been approved by Innovation, Science and Economic Development Canada to operate with the antenna types listed below, with the maximum gain indicated. Antenna types not included in this list that have a gain greater than the maximum gain indicated for any type listed are strictly prohibited for use with this device.

	BAND 12/17	BAND 13	BAND 5	BAND 4	BAND 25/2
Outside antenna maximum permissible antenna gain (dBi) 50Ω	4.5	4.2	4.6	3.81	4.74
Inside antenna maximum permissible antenna gain (dBi) 50Ω	4.16	4.16	6.09	6.66	9.77

### MOBILE INSIDE ANTENNA KIT OPTIONS

Kit #	Coax Type	Ln(ft)	Antenna Type	Ω
314401	LMR-100	10	Low Profile In-Vehicle SMA	50

### MOBILE OUTSIDE ANTENNA KIT OPTIONS

Kit #	Coax Type	Ln(ft)	Antenna Type	Ω
311229	LMR195	15	OTR Antenna Truck Edition	50
301126	LMR-100	10	Mini-Mag Antenna SMA	50
314405	RG-58	14	NMO Vehicle Antenna	50
311125	RG-174	12.5	12" Mag Mount	50

# Specifications

Drive X OTR Cell Signal Booster					
Model	460021				
FCC	PWO460021				
IC	4726A-460021				
Connectors	SMA-Female				
Antenna Impedance	50 Ohms				
Frequency	699-716 MHz, 729-756 MHz, 777-786 MHz, 824-894 MHz, 1850-1995 MHz, 1710-1755 MHz/2110-2155 MHz				
Power output for single cell phone (Uplink) dBm	<b>700 MHz B12/17</b> 24.84	<b>700 MHz B13</b> 24.35	<b>800 MHz B5</b> 23.4	<b>1700 MHz B4</b> 21.3	<b>1900 MHz B2</b> 24.43
Power output for single cell phone (Downlink) dBm	2.87	2.79	2.8	<b>2100 MHz B4</b> 2.0	1.92
Noise Figure	5 dB (nominal)				
Isolation	> 90 dB				
Power Requirements	6 V 2 A				

Each Signal Booster is individually tested and factory set to ensure FCC compliance. The Signal Booster cannot be adjusted without factory reprogramming or disabling the hardware. The Signal Booster will amplify, but not alter incoming and outgoing signals in order to increase coverage of authorized frequency bands only. If the Signal Booster is not in use for five minutes, it will reduce gain until a signal is detected. If a detected signal is too high in a frequency band, or if the Signal Booster detects an oscillation, the Signal Booster will automatically turn the power off on that band. For a detected oscillation the Signal Booster will automatically resume normal operation after a minimum of 1 minute. After 5 (five) such automatic restarts, any problematic bands are permanently shut off until the Signal Booster has been manually restarted by momentarily removing power from the Signal Booster. Noise power, gain, and linearity are maintained by the Signal Booster's microprocessor.

The term "IC" before the radio certification number only signifies that Industry Canada technical specifications were met. This device complies with Part 15 of FCC rules. This device contains licence-exempt transmitter(s)/receiver(s) that comply with Innovation, Science and Economic Development Canada's licence-exempt RSS(s). Operation is subject to the following two conditions: (1) This device may not cause interference, and (2) This device must accept any interference, including interference that may cause undesired operation of the device. Changes or modifications not expressly approved by weBoost could void the authority to operate this equipment.

## ✔ 2 YEAR WARRANTY

weBoost Signal Boosters are warrantied for two (2) years against defects in workmanship and/or materials. Warranty cases may be resolved by returning the product directly to the reseller with a dated proof of purchase.

Signal Boosters may also be returned directly to the manufacturer at the consumer's expense, with a dated proof of purchase and a Returned Material Authorization (RMA) number supplied by weBoost. weBoost shall, at its option, either repair or replace the product.

This warranty does not apply to any Signal Boosters determined by weBoost to have been subjected to misuse, abuse, neglect, or mishandling that alters or damages physical or electronic properties.

Replacement products may include refurbished weBoost products that have been recertified to conform with product specifications.



RMA numbers may be obtained by contacting Customer Support.

**DISCLAIMER:** The information provided by weBoost is believed to be complete and accurate. However, no responsibility is assumed by weBoost for any business or personal losses arising from its use, or for any infringements of patents or other rights of third parties that may result from its use.

# we:boost



3301 East Deseret Drive, St. George, UT

 1-866-294-1660  [www.weboost.com](http://www.weboost.com)  [support@weboost.com](mailto:support@weboost.com)

Copyright © 2017 weBoost. All rights reserved. weBoost products covered by U.S. patent(s) and pending application(s)  
For patents go to: [weboost.com/us/patents](http://weboost.com/us/patents)

NOT AFFILIATED WITH WILSON ANTENNA

GDE000588\_Rev01\_03.18.24