

DETAIL B  
SCALE 4 : 1

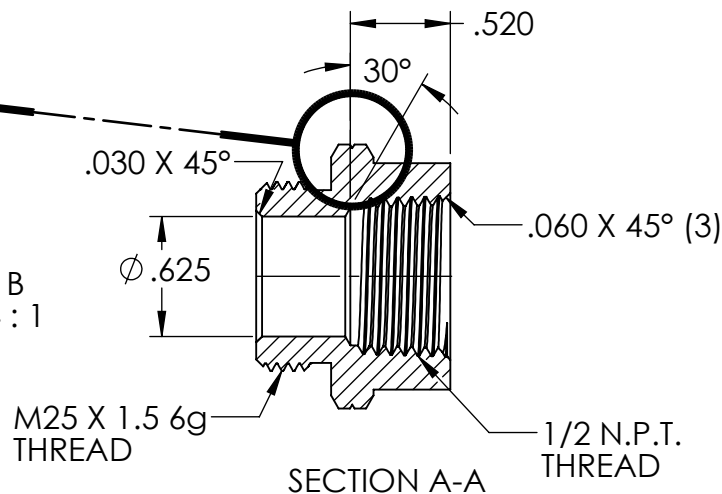
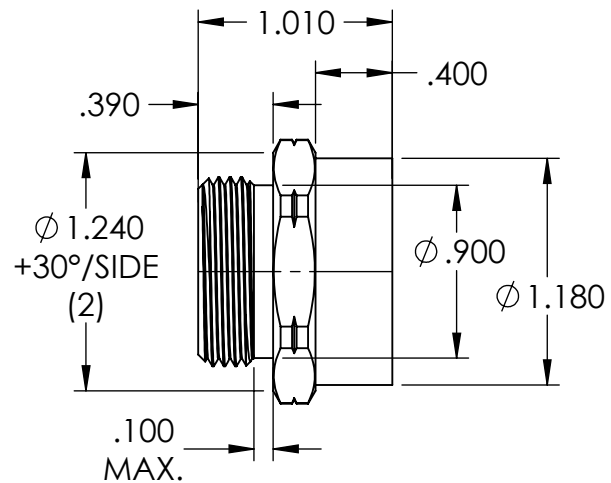

NOTES:

- 1.) PART A IS PLATED ELECTROLESS NICKEL .0001 MIN-.0003 MAX.
- 2.) PART UP IS UNPLATED
- 3.) BREAK ALL SHARP CORNERS
- 4.) REF. BAR-04 (1-1/4" HEX SOLID)

| REV. | DATE    | CHANGE  | UNLESS OTHERWISE SPECIFIED:          | NAME  | DATE     | <b>REMKE</b><br><b>REMKE INDUSTRIES</b><br>310 CHADDICK DR, WHEELING, IL. 60090 |              |
|------|---------|---|--------------------------------------|---|----------|---|--------------|
| A    | 5/17/02 | DRAWING RELEASED C.V.   | DIMENSIONS ARE IN INCHES             | DRAWN   | JCN 7/15 | TITLE:  |              |
| B    | 5/21/02 | REDRAWN AND REDIMENSIONED FOR TOOLING & PRODUCTION RELEASE C.V. | TOLERANCES:                          | CHECKED   |          | ADAPTER   |              |
| C    | 7/16/15 | REDRAWN   | FRACTIONAL ± 1/64                    | ENG APPR.   |          | SIZE  | DWG. NO.     |
|      |         |   | ANGULAR: MACH ± 1° BEND ± 1°         | MFG APPR.   |          | <b>A</b>  | RAM-25M50F-A |
|      |         |   | ONE PLACE DECIMAL ± .015             | Q.A.  |          | SCALE: 1:1  | SHEET 1 OF 1 |
|      |         |   | TWO PLACE DECIMAL ± .010             | <b>PROPRIETARY AND CONFIDENTIAL</b><br>THE INFORMATION CONTAINED IN THIS DRAWING IS THE SOLE PROPERTY OF REMKE INDUSTRIES. ANY REPRODUCTION IN PART OR AS A WHOLE WITHOUT THE WRITTEN PERMISSION OF REMKE INDUSTRIES IS PROHIBITED. |          |   |              |
|      |         |   | THREE PLACE DECIMAL ± .005           |   |          |   |              |
|      |         |   | INTERPRET GEOMETRIC TOLERANCING PER: |   |          |   |              |
|      |         |   | MATERIAL                             |   |          |   |              |
|      |         |   | ALUMINUM                             |   |          |   |              |
|      |         |   | FINISH                               |   |          |   |              |
|      |         |   | NICKEL PLATED                        |   |          |   |              |
|      |         |   | DO NOT SCALE DRAWING                 |   |          |   |              |

5

4

3

2

1