

# POWER DISTRIBUTION BLOCKS: NPDB-22-600-1



FUSE TABLE	
Overcurrent Protection, Fuse Required Class	Maximum Amp Rating
Class J	110A
Class T	110A
Class RK1	60A
Class RK5	30A
Class G	60A
Class CC	30A

## FEATURES:

- 1. AVAILABLE IN FINGER SAFE STYLE MODEL ONLY THAT INCLUDE END PLATES AND HINGED COVER
- 2. FINGER SAFE TO IP20. PER. IEC60529
- 3. cULus LISTED TO UL 1953 AND 1059
- 4. AL9CU RATED FOR USE WITH COPPER OR ALUMINUM CONDUCTOR CLASS B & C, AND OPERATING TEMP OF 90C
- 5. VOLTAGE RATING 600 V
- 6. DEFAULT SCCR (SHORT CIRCUIT CURRENT RATING) WITH CORRECT FUSING = 100KA
- 7. QUICK RELEASE LOCKING MECHANISM TO DISCONNECT FROM STD.35MM DIN RAIL
- 8. OVAL ALIGN MOUNTING HOLE AT BASE ON EITHER WIRE ENTRY END
- 9. MATERIAL: COVER AND END PLATES = LEXAN 500R POLYCARBONATE
- 10. MATERIAL: BASE AND SIDE PANELS = VAALOX NYLON 6/6 GF30%
- 11. MATERIAL: CONNECTOR BLOCK 6061T6 ALUMINUM TIN PLATED
- 12. MATERIAL: WIRE PORT SCREWS, STEEL TIN PLATED
- 13. MATERIAL: CONNECTOR TO BLOCK SECURITY SCREW, STEEL TIN PLATED
- 14. MULTI-PORT GANGING OF SAME SIZE BLOCK (SML, MED, LRG)
- 15. MAXIMUM AMPACITY PER POLE = 840A
- 16. PRIMARY (LINE, RUN, MAIN ) SIDE = 600 MCM
- 17. PRIMARY MAXIMUM TORQUE VALUE = 442 IN.LBF
- 18. PRIMARY STRIP LENGTH = 1.00"
- 19. MAXIMUM AMPACITY PER POLE = 840A
- 20. SECONDARY (LINE, RUN, MAIN ) SIDE = 600 MCM
- 21. SECONDARY MAXIMUM TORQUE VALUE = 442 IN.LBF
- 22. SECONDARY STRIP LENGTH = 1.00"

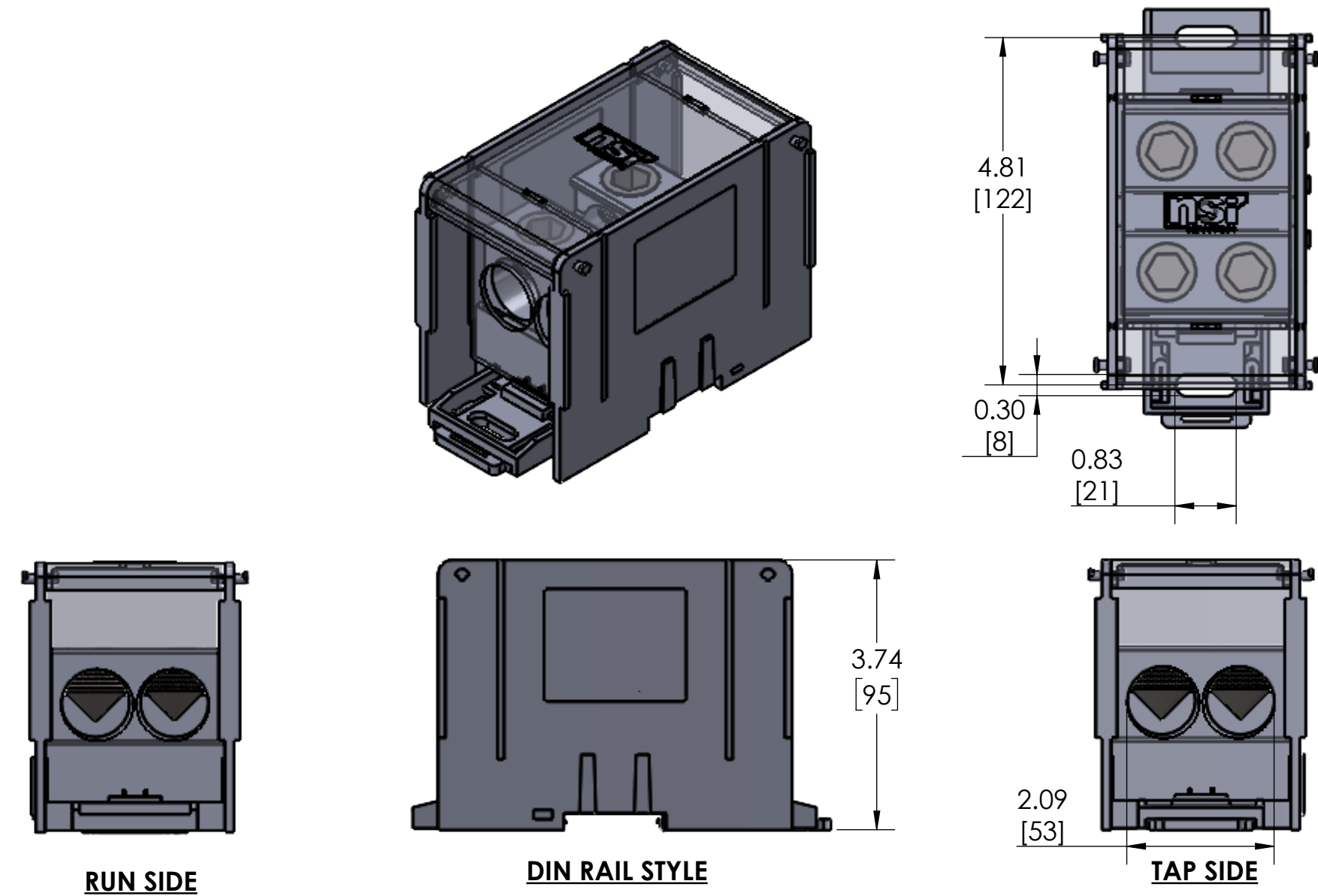

## 2: TORQUE VALUES

WIRE RANGE (MCM/AWG)	CONNECTOR SIZE									
	750	600	500	350	250	3/0	2/0	1/0	#2	#4
750 - 600	550	550								
500	550	450	450							
400	550	450	450							
350	550	400	400	400						
250	550	360	360	360	360					
4/0 - 3/0	550	250	250	250	250	250				
2/0	550	180	180	180	180	180	120			
1/0	550	180	180	180	180	180	80	80		
#1		150	150	150	150	150	65	65		
#2 - #3		150	150	150	150	150	65	65	65	
#4 - #6		150	110	110	110	110	55	55	35	35
#8				75			45	45	25	25
#10 - #14				35			25	25	15	15

NPDB -	22 -	600 -	1
NSI PRODUCT GROUP POWER DISTRIBUTION BLOCKS	1ST DIGIT = # OF PRIMARY COND. 2ND DIGIT = # OF SECONDARY COND.	MAXIMUM WIRE SIZE	NUMBER OF POLES

- NOTES:
- DIMENSIONS IN BRACKETS [ ] ARE IN MM ROUNDED OFF TO THE NEAREST MM, UNLESS OTHERWISE SPECIFIED AND ARE FOR REFERENCE ONLY
  - MATERIALS: BASE, POLE SEPERATING SIDE AND LOCK - NYLON 66 GF30% BLOCK AND RETENTION SCREWS - TIN PLATED ALUMINUM FINGER SAFE COVERS - POLYCARBONATE  
BLOCK MOUNTING HARDWARE - STAINLESS STEEL
  - MAY BE USED IN ANY NUMBER OF POLES REQUIRED.

