



HALO[®]

**USER MANUAL FOR
BOLT ULTIMATE™ 4.0**



SAFETY INSTRUCTIONS

**FOR ALL QUESTIONS RELATED TO SAFETY, WARRANTY
OR EXCHANGE REQUESTS, PLEASE CONTACT US.**

1-800-255-6061

YOUR SAFETY IS IMPORTANT TO US.

Please read instructions carefully and utilize the proper precautions before operating this equipment. Save instructions for future reference.

- When used correctly, lithium-ion rechargeable batteries provide a safe and dependable source of portable power. However, if they are misused or abused, this may result in leakage, burns, fire, or explosion, causing personal injury or damage to other devices.
- Misusing or incorrectly connecting your jump starter may cause electric shock to users and damage equipment.
- Keep your jump starter dry and away from moisture, water, and corrosive materials.
- Do not expose your jump starter to moisture, water, rain, or snow.
- Keep your jump starter away from heat sources, including open flames, radiators, stoves, ovens, and any other devices that produce heat.
- Do not expose to fire or excessive temperature. Do not expose to heat above 212°F (100°C) or incinerate.
- In the unlikely event of leakage or explosion use sand or a chemical fire extinguisher.
- Your jump starter may become warm under extended high power operation. Do not cover, wrap, or otherwise restrict air flow around the jump starter during operation.
- Do not disassemble your jump starter. There are no user-serviceable parts inside. Incorrect reassembly may result in shock or fire hazard.
- Do not drop or subject to strong impacts. Do not operate your jump starter if it has received a sharp blow, or has otherwise been damaged in any way.
- Do not puncture, crush, or subject to mechanical shock.
- Keep away from children and pets. The jump starter, along with its accessories are not toys.
- Make sure the jumper cables are fully plugged into the jump start output before trying to jump start your vehicle.
- Do not touch red (positive) and black (negative) jumper clamps together at any point.
- Make sure the jump starter's charging ports do not become contaminated with lint or other debris. Use a canned-air type of product periodically to ensure that the port openings are clear.

PRODUCT MAINTENANCE



IF THE JUMP STARTER OVERHEATS, BECOMES SWOLLEN, OR IS DEFORMED IN ANY WAY, IMMEDIATELY STOP USING THE PRODUCT AND CONTACT CUSTOMER SERVICE.

EQUIPMENT CLEANING:

- Please make sure that the device is disconnected from all input power and output devices.
- Wipe with a clean, dry cloth.
- Do not use corrosive cleaners or solvents.
- Do not insert metal objects into the ports to clean them as this could cause electrical shock. Blow any debris out with a canned-air type of product.



DISPOSAL/RECYCLING:

Do not put the device and its accessories in the trash can. Items must be properly handled in accordance with local laws and regulations. For additional information, please see www.epa.gov.



Li-ion



Cancer and Reproductive Harm
www.P65Warnings.ca.gov

**CONFORMS TO
UL2743**



Intertek

PRODUCT OVERVIEW

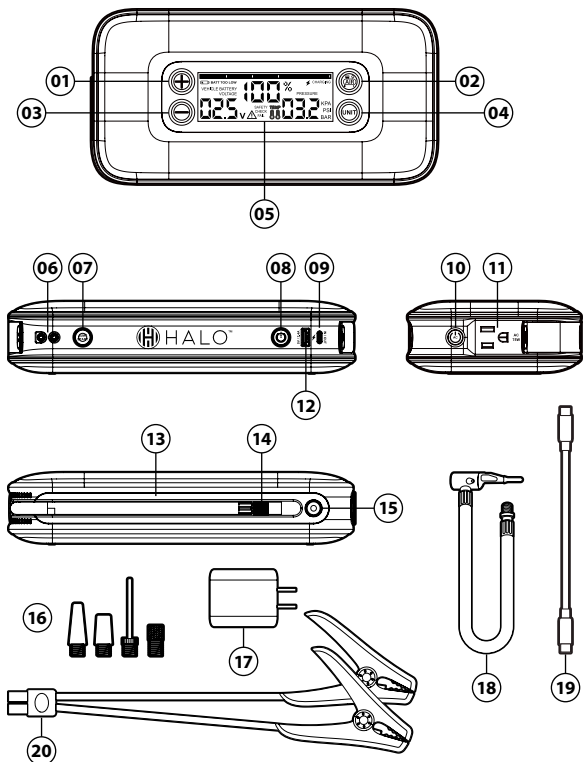

- | | |
|-----------------------------------|--|
| 1 Increase Air Pressure | 11 AC Output Port |
| 2 Air Compressor ON/OFF | 12 USB-A Output |
| 3 Decrease Air Pressure | 13 LED Floodlight |
| 4 Air Pressure Unit Button | 14 Air Compressor Hose |
| 5 Digital Display | 15 LED Floodlight ON/OFF Button |
| 6 Jump Start Output | 16 Interchangeable Air Nozzle Kit |
| 7 Jump Start ON/OFF Button | 17 30W PD USB-C Charging Adapter |
| 8 USB ON/OFF Button | 18 24" Air Hose Extension |
| 9 USB-C Input/Output | 19 24" USB-C to USB-C Cable |
| 10 AC ON/OFF Button | 20 16" Jumper Cable Clamps |

DIGITAL DISPLAY

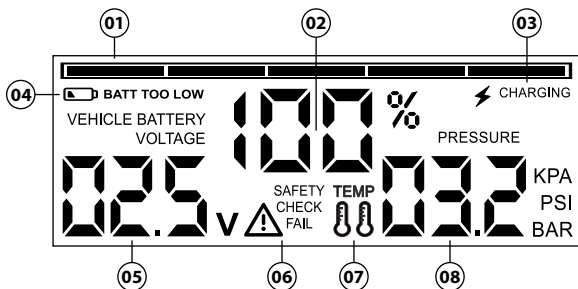

1. BATTERY FUEL GAUGE INDICATORS

Each bar presents 20% of the charge capacity.

2. BATTERY PERCENTAGE

Displays the current battery level.

3. UNIT IS CHARGING

When on, this indicates the unit is plugged in and charging.

4. BATTERY TOO LOW

The jump starter is not sufficiently charged to jump start the vehicle.

5. VOLTMETER

Will illuminate when the vehicle's battery voltage is detected.

6. SAFETY CHECK FAIL

A "SAFETY CHECK FAIL" has been triggered.

7. TEMPERATURE

A high or low temperature has been detected.

8. PRESSURE UNIT DISPLAY

Displays air pressure in KPA, PSI or BAR.

CHARGE YOUR BOLT ULTIMATE 4.0

Fully charge the jump starter before using. To charge, connect the jump starter to the included USB-C cable. The unit can be recharged from any USB powered port, like a wall adapter, car adapter, laptop and more. The USB-C input port is rated for 30W and should be fully charged in less than 3hrs (0-100%).

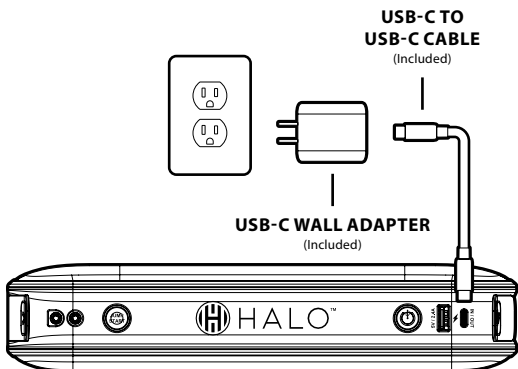

JUMP START YOUR VEHICLE

IMPORTANT: Before connecting the jumper cables, ensure there is no obvious corrosion or dirt on the battery terminals. A direct connection to the positive (+) and negative (-) terminals is recommended. Be sure to follow the vehicle's specific recommended mounting points as pointed out by the vehicle manufacturer.

BEFORE YOU GET STARTED

1. Make sure the jump starter has at least 50% charge.
2. You can not jump start while using the USB charge function or the air compressor.
3. Ensure the vehicle's headlights, radio, car alarm and air conditioning are turned off.
4. If you have an anti-theft system (car alarm) have your key fob ready to disable it before attempting to start your vehicle.

STEP 1: INSERT JUMPER CABLES

Plug the jumper cables into the jump-start output.

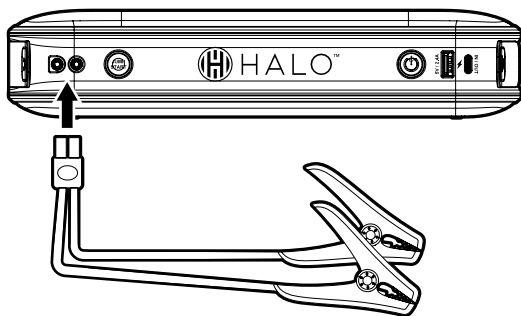

JUMP START YOUR VEHICLE

STEP 2: CONNECT TO BATTERY

Attach the jumper-cable clamps to the vehicle battery.

- Red clamp on positive terminal (+)
- Black clamp on negative terminal (-)

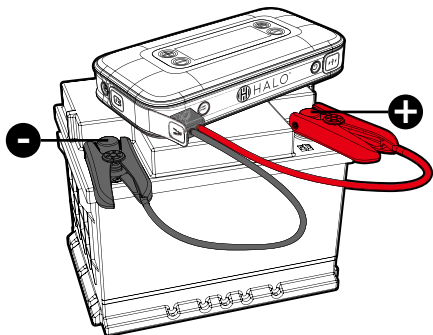

STEP 3: TURN IT ON

Press the "Jump Start" button to begin the safety check. The green light should flash for 3 seconds then turn solid. Once it is solid, you may attempt to disable your anti-theft system using your key fob. The vehicle battery should now have enough charge to power this system, and your car alarm may or may not begin to sound once this system is activated.



ONCE THE JUMP STARTER HAS A SOLID GREEN LIGHT, DO NOT REMOVE THE CLAMPS. DO NOT TOUCH THE CLAMPS TOGETHER.

NOTE: Once the green light is solid, it will only remain in this state for up to 90 seconds.

JUMP START YOUR VEHICLE

NOTE: If you need to reposition the clamps or stop the jump starting process, press the jump start button to safely disengage the jump starter.

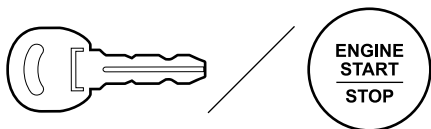

STEP 4: START YOUR VEHICLE

Start the vehicle. If it doesn't start immediately, wait 15 seconds before attempting to start again (repeat Step 3). Most vehicles should start the first time but some variables play a critical role in the starting process (temperature, engine size/type, battery condition). See the **TROUBLESHOOTING** section for more information.

STEP 5: DISCONNECT

Make sure the jump start button green LED is off. Carefully disconnect the jump starter cable clamps from the car battery.

HOW TO USE THE FLOODLIGHT

The multi-mode floodlight cycles through the following stages each time the button is pressed:

1. Floodlight ON/OFF button once = ON White Floodlight
2. Floodlight ON/OFF button twice = ON Red Floodlight
3. Floodlight ON/OFF button three times = ON Emergency Red S.O.S.
4. Floodlight ON/OFF button four times = OFF

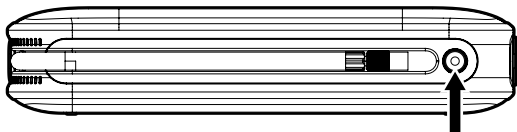

**LOOKING DIRECTLY INTO THE FLOODLIGHT CAN
RESULT IN MINOR OR MODERATE INJURY.**

AIR COMPRESSOR

STEP 1: CONNECT

Connect the air hose to the tire or use the appropriate nozzle to connect to your inflatable device.

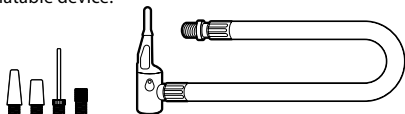

STEP 2: SET DESIRED PRESSURE

Press the (+) or (-) button to set the desired pressure. The pressure measuring units can be changed by pressing the UNIT button.

STEP 3: INFLATE

Once the desired pressure has been set, begin inflating by pressing the Air Compressor ON/OFF button. The air compressor will shut off automatically once the pressure has been reached.

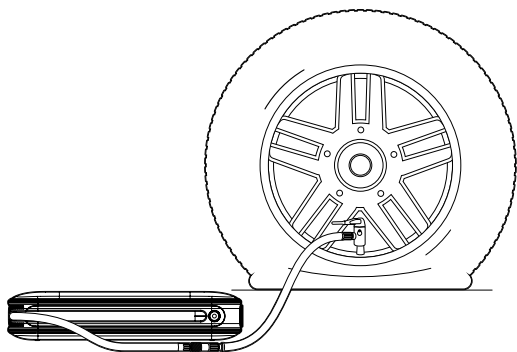

NOTE: The air compressor can be started or stopped at any point by pressing the air compressor ON/OFF button. The (+) and (-) may be long pressed to set the desired pressure quickly.

NOTE: Always check and follow the manufacturer's recommended pressure. Use caution as the air hose and connectors may get hot after extended use. The Bolt Ultimate 4.0 compressor is designed to automatically stop after an extended run-time or if an over-temperature protection set point is reached.

CHARGE YOUR DEVICES

USB-A output port is rated for up to 12W.

USB-C output port is rated for up to 30W.

1. Connect the appropriate cable to your device.
2. Plug the cable into the appropriate USB output port.
3. Press the USB ON/OFF button to begin charging your device.

NOTE: It is recommended to use charging cables provided by the manufacturer of your devices.

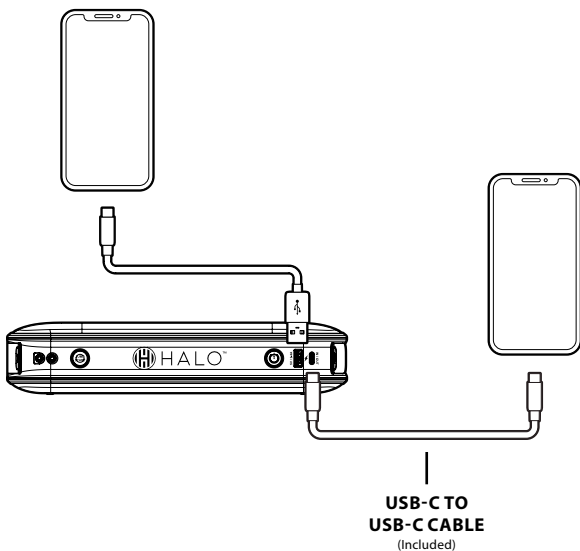

CHARGING A LAPTOP

NOTE: Electronic devices can be powered by the AC output port as long as it is rated at 75 watts or less. Ensure the electronic device is rated at 75 watts or less.

STEP 1: CONNECT

Connect the AC power plug from your laptop into the AC output port.

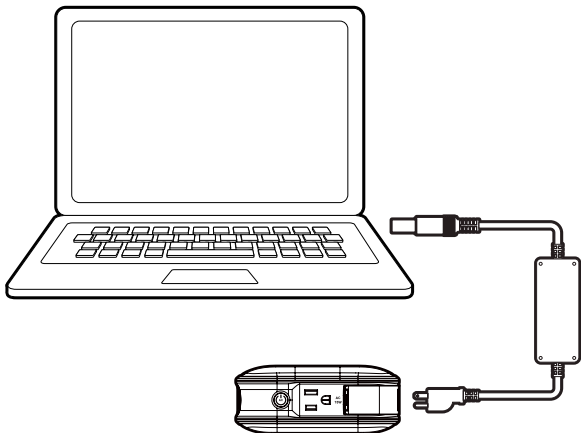

STEP 2: POWER ON

Press the AC Power ON/OFF Button and wait for a solid green light.

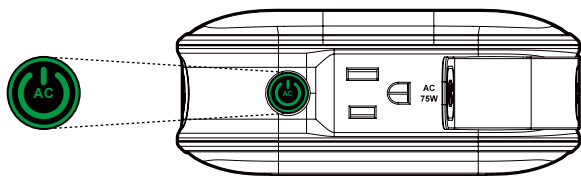

NOTE: Make sure the AC power plug is fully plugged into the AC port before pressing the AC Power ON/OFF Button.

NOTE: The Bolt Ultimate 4.0 charger will automatically power off after 30 minutes of inactivity.



TROUBLESHOOTING

FOR ALL QUESTIONS RELATED TO SAFETY, WARRANTY
OR EXCHANGE REQUESTS, PLEASE CONTACT US.

1-800-255-6061

JUMP STARTING IN COLD ENVIRONMENTS: In extreme cold environments, the jump starter should allow a jump start, but the vehicle battery may require a few attempts. If it doesn't jump the first time, try again. Each attempt should contribute to warming the battery just enough to increase jump start performance.

NOTE: The jump starter is designed to allow a jump start when used within a safe temperature range.

ISSUE	POTENTIAL CAUSE	SOLUTION
Jump Start button has been pressed but nothing happens.	The USB ON/OFF Button or the Air Compressor ON/OFF Button has been pressed.	The jump start output can not be used in conjunction with the USB output or air compressor modes. Ensure that both USB and AIR Compressor modes are off.
Screen displays a red BATT TOO LOW message. 	Jump starter is not sufficiently charged to jump start the vehicle.	Recharge the jump starter and verify at least 50% charged. Then try the jump start process again.
Jump Start button flashes red and a SAFETY CHECK FAIL message is displayed. 	The jumper cables have not been properly connected to the vehicle battery.	Check the jumper cables and ensure that the red clamp is connected to the positive terminal (+) and the black clamp is connected to the negative terminal (-).

TROUBLESHOOTING

ISSUE	POTENTIAL CAUSE	SOLUTION
<p>Jump Start button flashes green continuously.</p> 	<p>The jump starter is waiting to be connected to a battery or a SAFETY CHECK FAIL has been triggered.</p>	<p>Check the jumper cables and ensure they are properly connected to the battery. Check and ensure the vehicle battery voltage is greater than 2.0V. If the SAFETY CHECK FAIL indicator is triggered during the jump start process, it is recommended that you consult with a certified mechanic.</p>
<p>Screen displays a blue or red TEMP indicator.</p>  	<p>The jump starter has detected a low or high temperature condition.</p>	<p>Disconnect the jump starter and allow unit to acclimate to temperature operating range (14°F-122°F).</p>
<p>You cannot successfully jump start your vehicle. The jump starter displays a vehicle battery voltage greater than 12.0V.</p>	<p>The jump starter detects that it is connected to a vehicle battery with a normal starting voltage. This could indicate that another vehicle component is faulty.</p>	<p>It is recommended that you consult with a certified mechanic.</p>
<p>The Jump Start and On/Off button flashes red and blue.</p>	<p>This could occur when attempting to jump start a vehicle while other electrical components (i.e. headlights, heater, radio, etc.) are on.</p>	<p>Turn off your headlights and any other components that may drain your car battery and try the jump start process again.</p>
	<p>The vehicle battery may be faulty.</p>	<p>It is recommended that you consult with a certified mechanic.</p>

TROUBLESHOOTING

JUMP STARTING UNSUCCESSFUL WITH NO SAFETY CHECK FAIL ERROR DISPLAYED (ANTI-THEFT SYSTEM):

If you are unable to successfully jump start your vehicle after passing the safety check and getting a solid green Jump Start light, it could be that your vehicle is equipped with an anti-theft system. These systems are designed to prevent the vehicle from starting if it detects tampering, and a dead car battery may trigger this incorrectly. It is possible that your car alarm will not sound even if the anti-theft system has been activated, so refer to your dashboard for an indicator light that identifies the anti-theft system is active and your owner's manual for a specific way to bypass the anti-theft system. In some cases, you can use your key fob button to deactivate your alarm after connecting the jump starter and pressing the Jump Start ON/OFF button. Doing so may provide enough of a charge to the vehicle battery for the anti-theft system to respond to your key fob. Once you are able to deactivate the anti-theft system, and the Jump Start ON/OFF button is solid green, you may attempt to start your vehicle.

AC OUTPUT TROUBLESHOOTING

ISSUE	POTENTIAL CAUSE	SOLUTION
AC button flashes red.	Electronic device is rated greater than 75 watts.	Only electronic devices rated at 75 watts or less can be used.
	The Bolt Ultimate battery is not sufficiently charged to power the connected electronic device.	Recharge the Bolt Ultimate battery.
Bolt Ultimate shuts off unexpectedly.	The Bolt Ultimate battery is not sufficiently charged to power the connected electronic device.	Recharge the Bolt Ultimate battery.
Bolt Ultimate displays a blue or red TEMP indicator.	The Bolt Ultimate has detected a low or high temperature condition.	Disconnect the Bolt Ultimate and allow the unit to acclimate to temperature operating range 14°-104°F (-10°-40°C).

PRODUCT REGISTRATION

Scan the QR code below to register your product.
For product information and videos, visit WWW.HALOPWR.COM



**PRODUCT
REGISTRATION**

ACTIVATE YOUR WARRANTY TODAY

Your HALO jump starter has a 90 day warranty from the date of purchase. By registering your warranty, you will help protect your investment and save a record of your purchase with our customer service team.

TECHNICAL SPECIFICATIONS

USB-C Input/Output	PD 30W Max
USB-A Output	5VDC/2.4A
Peak Current Rating	1500A
Floodlight Output	80lm
AC Output	75W
Air Compressor	150PSI
Battery Capacity	56.6Wh
Operating Temperature	Charge: 32°-113°F (0°-45°C) Discharge: 14°-104°F (-10°-40°C)
Storage Temperature	-4°-140°F (-20°-60°C)
Dimensions	10.5 x 5.25 x 2.13 in. (265 x 133 x 53mm)
Weight	2.9 lb. (1.32kg)

FCC NOTE

COMPLIANCE WITH FCC REGULATION

This device complies with part 15 of the FCC Rules and RSS-Gen of IC Rules. Operation is subject to the following two conditions: (1) This device may not cause harmful interference, and (2) this device must accept any interference received, including interference that may cause undesired operation.

NOTE: This equipment has been tested and found to comply with the limits for a Class B digital device, pursuant to part 15 of the FCC Rules. These limits are designed to provide reasonable protection against harmful interference in a residential installation. This equipment generates, uses, and can radiate radio frequency energy and, if not installed and used in accordance with the instructions, may cause harmful interference to radio communications. However, there is no guarantee that interference will not occur in a particular installation. If this equipment does cause harmful interference to radio or television reception, which can be determined by turning the equipment off and on, the user is encouraged to try to correct the interference by one or more of the following measures:

- Reorient or relocate the receiving antenna.
- Increase the separation between the equipment and receiver.
- Connect the equipment into an outlet on a circuit different from that to which the receiver is connected.
- Consult the dealer or an experienced technician for help.
- Any changes or modifications not expressly approved by the party responsible for compliance could void the user's authority to operate the equipment.

CAUTION: To comply with the limits of the Class B digital device, pursuant to Part 15 of the FCC Rules, this device must be used with certified peripherals and shielded cables. All peripherals must be shielded and grounded. Operation with non-certified peripherals or non-shielded cables may result in interference to radio or reception.

ALLIANCE CONSUMER GROUP

700 Henrietta Creek Rd, Roanoke, Texas 76262

Toll-Free: 800.255.6061

www.acgbrands.com

TRANSPORTING DANGEROUS GOODS

NOTE: Any changes or modifications of this device could void the warranty.



Fully charge before using



Do not disassemble



Use original or certified charger or cable



It's not waterproof, do not expose to liquids



Avoid extreme temperature



Dispose of batteries and electronic goods in accordance with local regulations



Avoid dropping

This jump starter meets all legal requirements for the transportation of dangerous goods. According to international standards, if the jump starter is transported by air, it must be transported in accordance with IATA standard packaging. The instructions and labeling requirements of the International Air Transport Association and related declarations must be completed.



HALO®

WWW.HALOPWR.COM