

NUT

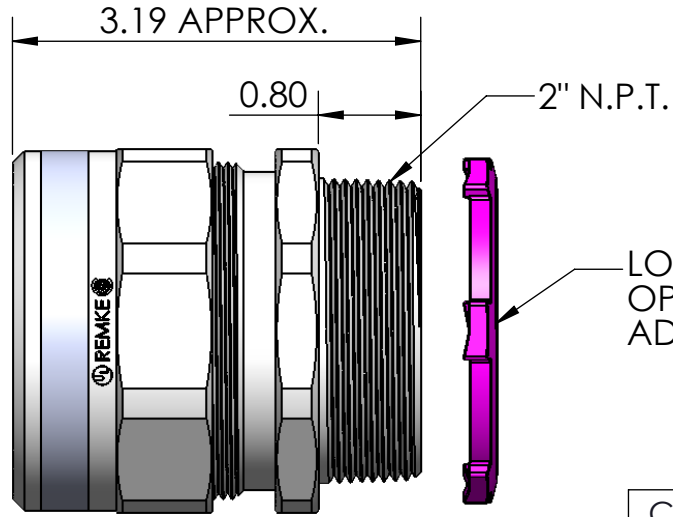

LOCK NUT
OPTIONAL
ADD: L



CATALOG NUMBER	SEALING RANGE	BODY BORE
RSR-612	.562 - .688	2.000
RSR-613	.688 - .812	2.000
RSR-614	.750 - .875	2.000
RSR-617	.937 - 1.062	2.000
RSR-618	1.000 - 1.125	2.000
RSR-620	1.125 - 1.250	2.000
RSR-622	1.250 - 1.375	2.000
RSR-623	1.312 - 1.437	2.000
RSR-625	1.438 - 1.562	2.000
RSR-627	1.562 - 1.687	2.000
RSR-629	1.688 - 1.812	2.000

ITEM NO.	PART NUMBER	DESCRIPTION	MATERIAL	QTY.
1	RSR-600-B	BODY	ALUMINUM	1
2	SRB-611 THRU SRB-629	BUSHING	NEOPRENE	1
3	SW-600	WASHER	C.R.S. ZINC PLATED	1
4	RSR-600-N	NUT	ALUMINUM	1
5	LN-200	LOCK NUT	ADD: L, C.R.S. ZINC PLATED	1

REV.	DATE	CHANGE	UNLESS OTHERWISE SPECIFIED:	NAME	DATE	REMKE REMKE INDUSTRIES 310 CHADDICK DR, WHEELING, IL. 60090	
A	4/22/13	DRAWING RELEASED	DIMENSIONS ARE IN INCHES TOLERANCES: FRACTIONAL ± 1/64 ANGULAR: MACH ± 1° BEND ± 1° ONE PLACE DECIMAL ± .015 TWO PLACE DECIMAL ± .010 THREE PLACE DECIMAL ± .005 INTERPRET GEOMETRIC TOLERANCING PER: MATERIAL ALUMINUM FINISH DO NOT SCALE DRAWING	DRAWN JCN CHECKED ENG APPR. MFG APPR. Q.A.	4/13 PROPRIETARY AND CONFIDENTIAL THE INFORMATION CONTAINED IN THIS DRAWING IS THE SOLE PROPERTY OF REMKE INDUSTRIES. ANY REPRODUCTION IN PART OR AS A WHOLE WITHOUT THE WRITTEN PERMISSION OF REMKE INDUSTRIES IS PROHIBITED.	TITLE: RSR-600 SERIES SIZE A DWG. NO. RSR-600 ASSEMBLY SCALE: 2:3 SHEET 1 OF 1	