

we:boost™

Installation Guide

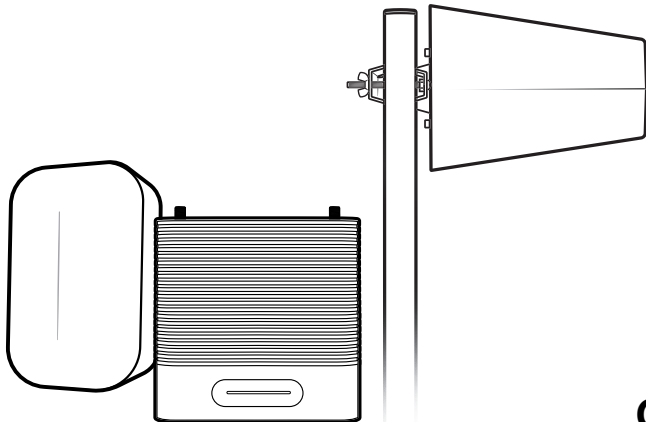

Cabin Cell Signal Booster for Remote Residences

Use our weBoost App to guide you through the installation. See inside page for more details.

Download the weBoost App

Use our app to guide you through setting up a weBoost cell phone signal booster in your home, business, or vehicle. Boost every network, including 5G, right away.



Index

Package Contents	1
Installation Overview	2
STEP 1 Inside Antenna & Booster Placement	3
STEP 2 Attach Pole Foot	4
STEP 3 Mount Outside Antenna to Telescoping Pole	4
STEP 4 Attach Pole Mount to Telescoping Pole	5
STEP 5 Identify Mounting Location	6
STEP 6 Mount Telescoping Pole to Cabin	7
STEP 7 Anchor the Pole Foot to Ground Surface	8
STEP 8 Route Cable & Connect to Booster	9
STEP 9 Route Cable & Connect Inside Antenna to Booster	10
STEP 10 Power Up the Booster	11
Measuring Booster Performance & Optimizing the System	13
Booster Light Patterns	16
Troubleshooting	18
Specifications	24
Warranty	25

Package Contents



Booster, Wall Mount
Bracket & Power Supply



Inside Antenna
& Mounting Bracket



Outside Antenna & Pole
Mounting Bracket



15' Coax Cable (Qty 2)
30' Coax Cable (Qty 1) &
Window Entry Cable

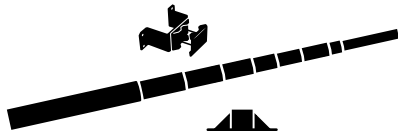

Telescoping Pole, Pole Mounting
Bracket & Pole Foot

Installation Overview

Before finalizing the installation, do a **soft install and optimize the system** for best coverage.

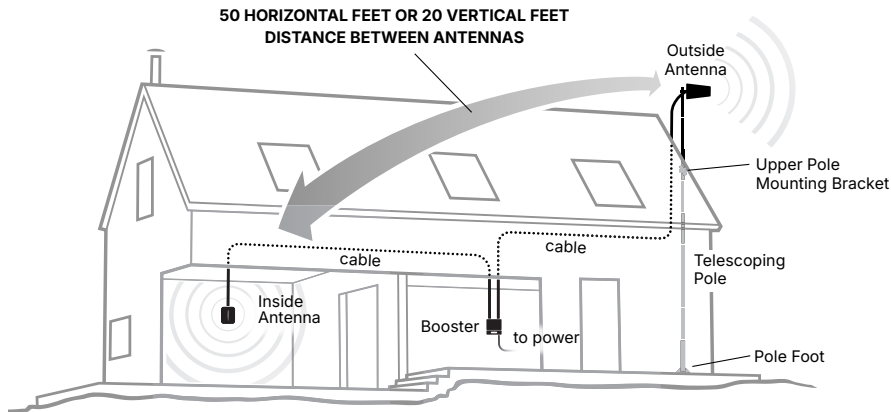

Window Entry Cable can be used to route cable through window if needed.

STEP 1 Inside Antenna & Booster Placement

Place the inside antenna where you need the greatest signal boost and place the booster in your desired location **at least 24 inches away** from inside antenna.

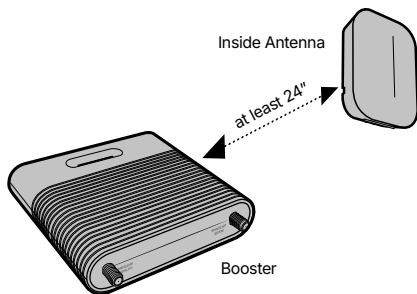

(STEP 1 cont.)

The inside antenna can be **mounted vertical, horizontal or on a desktop**. Command strips (or screws) can be used to secure mounting bracket to wall.

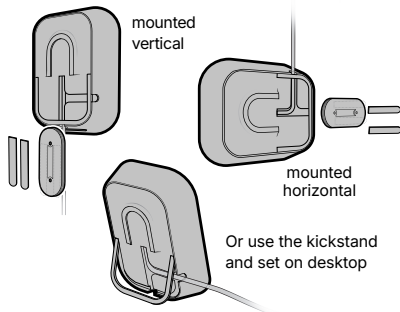

STEP 2 Attach Pole Foot

Slide pole into **pole foot**. It should be snug, so press firmly for a complete fit.

NOTE: Pole foot is intended for permanent attachment and should not be removed after installation.

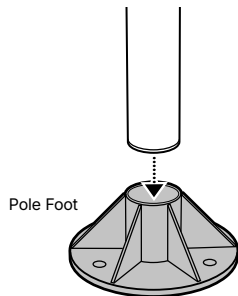

STEP 3 Mount Outside Antenna to Telescoping Pole

Mount outside antenna to top section of telescoping pole with mounting bracket. Connect a **15 foot coax cable** to outside antenna.

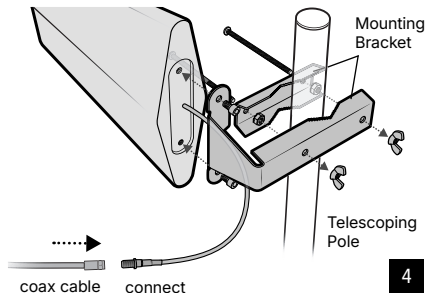

STEP 4 Attach Pole Mount to Telescoping Pole

Mount the **pole bracket** to either the **seventh or eighth section of the telescoping pole**. Ideally, this should be approximately 18 feet from the bottom of the fully extended pole.

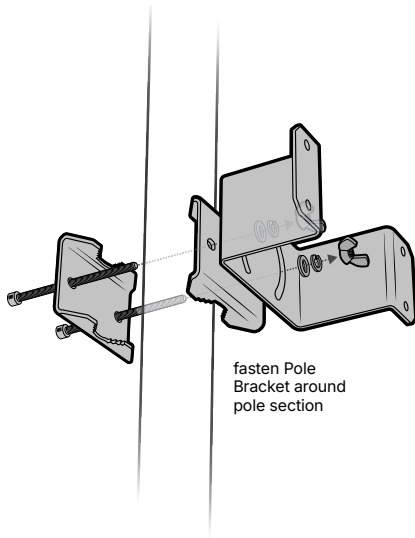

STEP 5 Identify Mounting Location

Identify the ideal installation location. **The ideal location would be:**

- **A stable area of your cabin, clear of any hazards, damage or deterioration.**
- **Where the outside antenna is at least 50 horizontal feet or 20 vertical feet from the inside antenna.**
- **The ground should be solid/compressed dirt, concrete or wood decking** (avoid mounting to Hardie™ decking and siding).

The pole bracket can be attached to the fascia of the cabin at the recommended height of 18 feet and vertically aligned with the ground mounting location. This would be the time to do a **soft installation** before permanently securing pole. Skip to steps 8, 9, 10 and test the system.

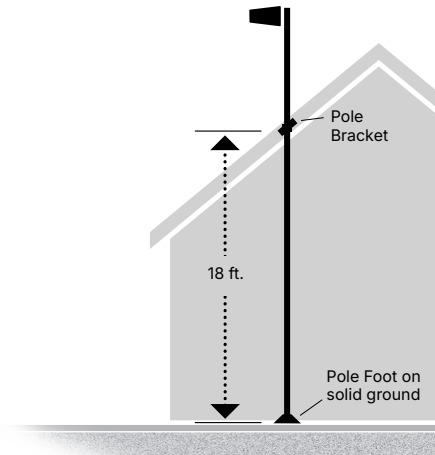

STEP 6 Mount Telescoping Pole to Cabin

Fully extend the telescoping pole as much as possible, ensuring the pole bracket is aligned with the fascia (or attachment point) of your cabin. **Attach mounting bracket to fascia of cabin** with appropriate screws/ fasteners. The bracket offers multiple mounting options by allowing installation at different angles.

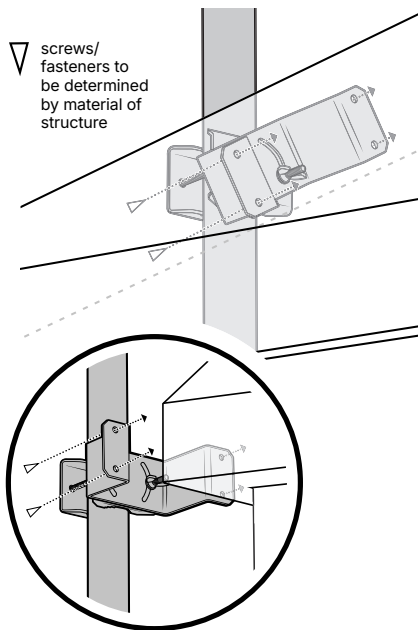

STEP 7 Anchor the Pole Foot to Ground Surface

Once bracket is installed, make sure pole is vertically aligned. Anchor the **pole foot to the ground surface**. Use the appropriate hardware to ensure complete stability. The ground should be solid/compressed dirt, concrete or wood decking (avoid mounting to Hardie™ decking and siding).

Hardware Options

- Compressed Dirt
10" heavy duty ground stakes
- Concrete
3/8" x 3" concrete anchor bolts
- Wood
3/8" x 3" lag bolts

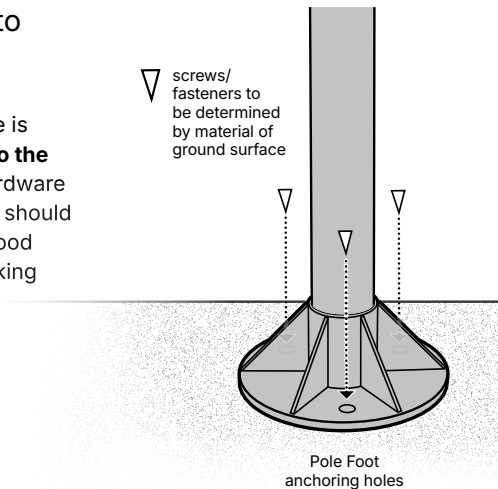

STEP 8 Route Cable & Connect to Booster

Route the 15 foot RG-6 cable(s) into the cabin. A **window entry cable** is provided to help make cable entry easier if needed. All connections should be finger tightened only.

Route the other 15 foot cable to the booster and connect to the port labeled **OUTSIDE ANTENNA.** Finger tighten only.

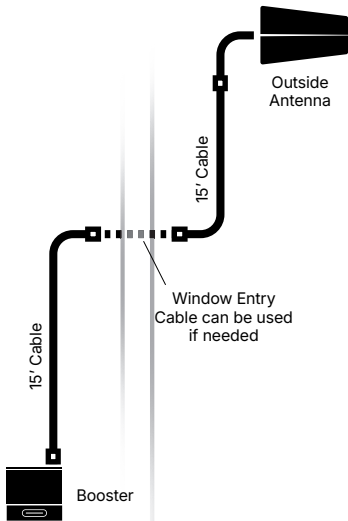
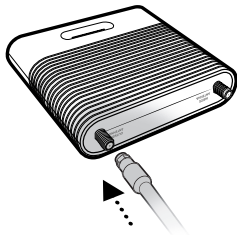

STEP 9 Route Cable & Connect Inside Antenna to Booster

Connect the 30 foot RG-6 cable to inside antenna and route to the booster and connect to the port labeled **INSIDE ANTENNA**. Finger tighten only.

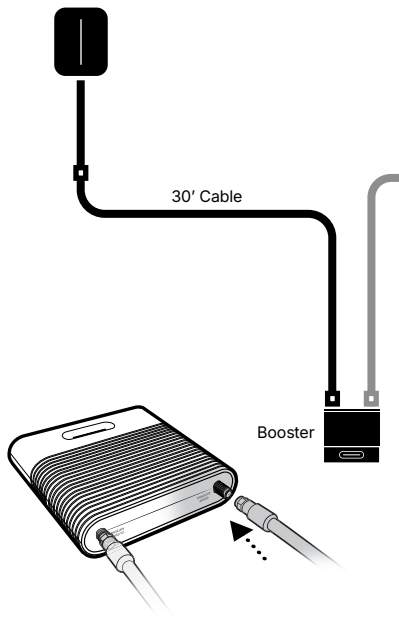

STEP 10 Power Up the Booster

Plug the power supply into wall outlet then connect to end of booster labeled **---**.

NOTE: We strongly recommend using a power strip with surge protection.

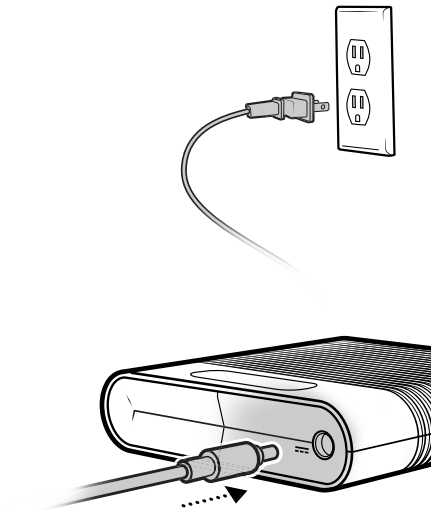

(STEP 10 cont.)

The booster can be mounted vertically with the **wall mount bracket** (included). The slide mount can be secured with command strips (included) or by screws.

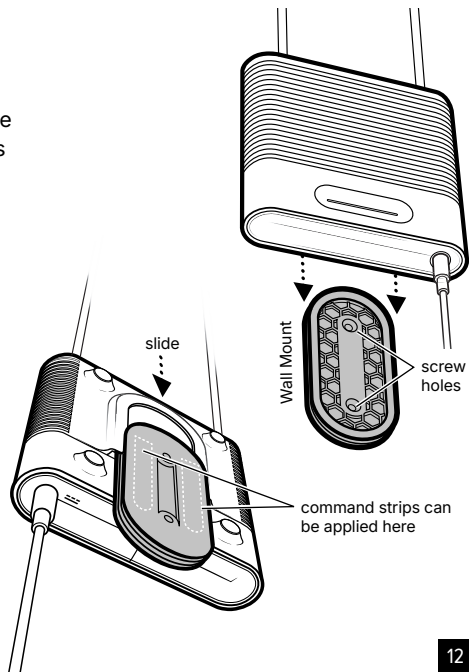

Measuring Booster Performance & Optimizing the System

We've created an easy way to learn your signal strength and compare it before and after a booster. Download our free weBoost app to get accurate decibel measurements to help you get the best performance from your system.



(Measuring Booster Performance & Optimizing the System cont.)

Signal Strength (dBm) with weBoost system powered OFF: _____
(dBm here)

Signal Strength (dBm) with weBoost system powered ON: _____
(dBm here)

Compare Results

Compare the decibels (dBm) on the chart below to find what signal strength you fall into.

Signal Strength	Excellent	Good	Fair	Poor	Dead Zone
3G/1x	-70dBm	-71 to -85dBm	-86 to -100dBm	-101 to -109dBm	-110dBm
4G/LTE	-90dBm	-91 to -105dBm	-106 to -110dBm	-111 to -119dBm	-120dBm

Did you know a signal increase of just 3dB is 2 times the power and signal amplification!

Gain Improvement	Signal Improvement
3dB	 2X
6dB	 4X
10dB	 10X
20dB	 100X

(Measuring Booster Performance & Optimizing the System cont.)

You can optimize your system to improve your signal strength by **rotating the outside antenna in 1/3 turn increments. After each turn, unplug and re-plug in booster's power supply**, while observing the signal level on your cell phone or in field test mode from the inside antenna's projected area.

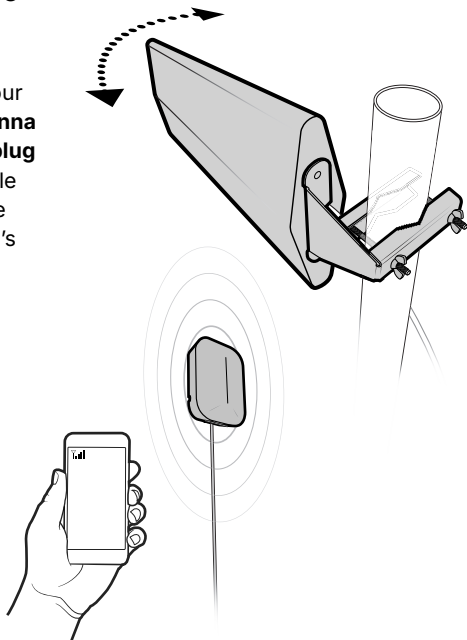

Booster Light Patterns

SOLID GREEN

This indicates that your booster is functioning properly and there are no issues with installation.

BLINKING GREEN & RED

Band has reduced gain. This indicates that one or more of the booster bands has reduced power due to a feedback loop condition called oscillation. This is a built in safety feature to prevent harmful interference with a nearby cell tower. If you are already experiencing the desired signal boost, then no further adjustments are necessary. If you are not experiencing the desired boost in coverage then refer to the Troubleshooting section.

SOLID RED

Band has shutoff. This is due to a feedback loop condition called oscillation. This is a built in safety feature that causes a band to shut off to prevent harmful interference with a nearby cell tower. Refer to Troubleshooting section.

BLINKING GREEN & YELLOW

Band has reduced gain. This indicates that one or more of the booster bands has reduced

(Booster Light Patterns cont.)

power due to overload from nearby cell tower. This is a built in safety feature to prevent harmful interference with a nearby cell tower. If you are already experiencing the desired signal boost, then no further adjustments are necessary. If you are not experiencing the desired boost in coverage then refer to the Troubleshooting section.

SOLID YELLOW

Band has shutoff due to overload from nearby cell tower. Outside Antenna must be adjusted. Refer to Troubleshooting section.

LIGHT OFF

If the Signal Booster's light is off, verify your power supply has power.

Troubleshooting

FIXING BLINKING OR RED LIGHT ISSUES

This section is only applicable if the light on the booster is red, blinking red or green /red lights.

- 1 Verify outside and inside antenna face away from each other. Un-plug and re-plug in power supply.
- 2 Verify the inside antenna is at least 61 centimeters from the booster and pointed away from the booster. Unplug and re-plug in power supply.
- 3 Tighten all cable connections (be sure to finger tighten only, do NOT use tools). You may want to undo and redo the connection completely. Unplug and re-plug in power supply.
- 4 Increase the distance (horizontally or vertically) between the outside and inside antenna. Add included cable if needed. Un-plug and re-plug in power supply.

If you are having any difficulties while testing or installing your booster, contact our weBoost Customer Support team for assistance (1-866-294-1660).

(Troubleshooting cont.)

FIXING BLINKING OR YELLOW LIGHT ISSUES

This section is only applicable if the light on the booster is yellow, blinking green /yellow lights.

Outside Antenna must be adjusted. Wait 10 seconds between adjustments for the lights to reset.

Pole Mount Option: Rotate the outside antenna away from the strongest cellular signal in small increments (1/3) until the light turns green. Unplug and re-plug in power supply.

Mounting On Side Of Roof Option: Change mount location. Move the outside antenna to a different location of the remote residence to see if the lights turn green. Un-plug and re-plug in power supply. Then secure in place.

 1-866-294-1660

 www.weboost.com

 support@weboost.com

(Troubleshooting cont.)

FREQUENTLY ASKED QUESTIONS

How can I contact customer support?

Customer Support can be reached Monday through Friday by calling 1-866-294-1660, or through our support site at support.weboost.com.

Why do I need to create distance between the outside antenna and inside antenna?

Antennas connected to a booster create spheres of signal. When these spheres overlap, a condition called oscillation occurs. Oscillation can be thought of as noise, which causes the booster to scale down its power or shut down to prevent damage. The best way to keep these spheres of signal from overlapping is to maximize separation between the inside and outside antennas.

Safety Guidelines

To uphold compliance with network protection standards, all active cellular devices must maintain at least six feet of distance from Inside Panel and Dome Antennas and at least four feet of distance from Desktop Antenna.

Use only the Power Supply provided in this package. Use of a non-weBoost product may damage your equipment.

The signal booster unit is designed for use in an indoor, temperature-controlled environment (less than 100 degrees Fahrenheit). It is not intended for use in attics or similar locations subject to temperatures in excess of that range.

RF Safety Warning: Any antenna used with this device must be located at least 8 inches from all persons.

AWS Warning: The Outside Antenna must be installed no higher than 31 feet 9 inches (10 meters) above ground.

This is a CONSUMER device.

BEFORE USE, you **MUST REGISTER THIS DEVICE** with your wireless provider and have your provider's consent. Most wireless providers consent to the use of signal boosters. Some providers may not consent to the use of this device on their network. If you are unsure, contact your provider.

In Canada, **BEFORE USE** you must meet all requirements set out in ISED CPC-2-1-05.

You **MUST** operate this device with approved antennas and cables as specified by the manufacturer. Antennas **MUST** be installed at least 20 cm (8 inches) from (i.e., **MUST NOT** be installed within 20 cm of) any person.

You **MUST** cease operating this device immediately if requested by the FCC (or ISED in Canada) or licensed wireless service provider.

WARNING. E911 location information may not be provided or may be inaccurate for calls served by using this device.

This device may be operated **ONLY** in a fixed location for in-building use.

(Safety Guidelines cont.)

FOR MORE INFORMATION ON REGISTERING YOUR SIGNAL BOOSTER WITH YOUR WIRELESS PROVIDER IN THE U.S., PLEASE GO TO THE LINK BELOW:

<https://www.weboost.com/carrier-registration>

Antenna Info

The following accessories are certified by the FCC to be used with the Home MultiRoom Booster.

This radio transmitter 4726A-460059 has been approved by Innovation, Science and Economic Development Canada to operate with the antenna types listed below, with the maximum gain indicated. Antenna types not included in this list that have a gain greater than the maximum gain indicated for any type listed are strictly prohibited for use with this device.

	BAND 12/17	BAND 13	BAND 5	BAND 4	BAND 25/2
Outside antenna maximum permissible antenna gain (dBi) 50Ω	4.9	4.9	4.5	4.6	4.2
Inside antenna maximum permissible antenna gain (dBi) 50Ω	3.2	3.2	3.2	2.6	2.7

FIXED INSIDE ANTENNA KIT OPTIONS

Kit #	Coax Type	Ln(ft)	Antenna Type	Ω
301211	RG-6	30	Desktop	75
304419	RG-6	30	Dome	75
314440	RG-6	30	Panel	75

FIXED OUTSIDE ANTENNA KIT OPTIONS

Kit #	Coax Type	Ln(ft)	Antenna Type	Ω
314445	RG-6	30	Directional	75
314475	RG-6	30	Directional	75
304423	RG-6	30	Omni	75
304421	RG-6	30	Omni	75

Specifications

Home MultiRoom Cell Signal Booster					
Model	460059				
FCC	PWO460059				
IC	4726A-460059				
Connectors	F-Female				
Antenna Impedance	75 Ohms				
Frequency	698-716 MHz, 729-746 MHz, 746-757 MHz, 776-787 MHz, 824-849 MHz, 869-894 MHz, 1710-1755 MHz 1850-1915 MHz, 1930-1995 MHz, 2110-2155 MHz				
Power output for single cell phone (Uplink) dBm	700 MHz B12/17 21.7	700 MHz B13 21.9	800 MHz B5 23.4	2100 MHz B4 22.7	1900 MHz B25/2 21.9
Power output for single cell phone (Downlink) dBm	12.2	12.3	12.6	12.5	12.5
Noise Figure	5 dB (nominal)				
Isolation	>110 dB				
Power Requirements	4.2 VDC				

Each Signal Booster is individually tested and factory set to ensure FCC compliance. The Signal Booster cannot be adjusted without factory reprogramming or disabling the hardware. The Signal Booster will amplify, but not alter incoming and outgoing signals in order to increase coverage of authorized frequency bands only. If the Signal Booster is not in use for five minutes, it will reduce gain until a signal is detected. If a detected signal is too high in a frequency band, or if the Signal Booster detects an oscillation, the Signal Booster will automatically turn the power off on that band. For a detected oscillation the Signal Booster will automatically resume normal operation after a minimum of 1 minute. After 5 (five) such automatic restarts, any problematic bands are permanently shut off until the Signal Booster has been manually restarted by momentarily removing power from the Signal Booster. Noise power, gain, and linearity are maintained by the Signal Booster's microprocessor.

The term "IC" before the radio certification number only signifies that Industry Canada technical specifications were met. This device complies with Part 15 of FCC rules. This device contains licence-exempt transmitter(s)/receiver(s) that comply with Innovation, Science and Economic Development Canada's licence-exempt RSS(s). Operation is subject to the following two conditions: (1) This device may not cause interference, and (2) This device must accept any interference, including interference that may cause undesired operation of the device. Changes or modifications not expressly approved by weBoost could void the authority to operate this equipment.

✔ 2 YEAR WARRANTY

weBoost Signal Boosters are warranted for two (2) years against defects in workmanship and/or materials. Warranty cases may be resolved by returning the product directly to the reseller with a dated proof of purchase.

Signal Boosters may also be returned directly to the manufacturer at the consumer's expense, with a dated proof of purchase and a Returned Material Authorization (RMA) number supplied by weBoost. weBoost shall, at its option, either repair or replace the product.

This warranty does not apply to any Signal Boosters determined by weBoost to have been subjected to misuse, abuse, neglect, or mishandling that alters or damages physical or electronic properties.

Replacement products may include refurbished weBoost products that have been recertified to conform with product specifications.



RMA numbers may be obtained by contacting Customer Support.

DISCLAIMER: The information provided by weBoost is believed to be complete and accurate. However, no responsibility is assumed by weBoost for any business or personal losses arising from its use, or for any infringements of patents or other rights of third parties that may result from its use.

we:boost



3301 East Deseret Drive, St. George, UT

 1-866-294-1660  www.weboost.com  support@weboost.com

Copyright © 2019 weBoost. All rights reserved. weBoost products covered by U.S. patent(s) and pending application(s)
For patents go to: weboost.com/us/patents

NOT AFFILIATED WITH WILSON ANTENNA

GDE000650_001_03.19.25