

SECTION A-A

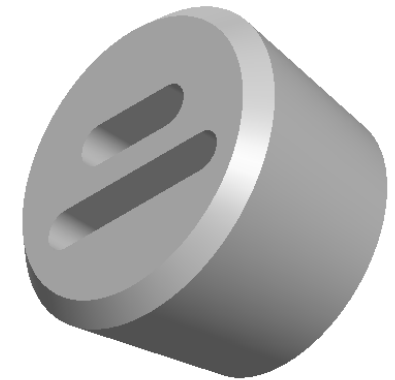
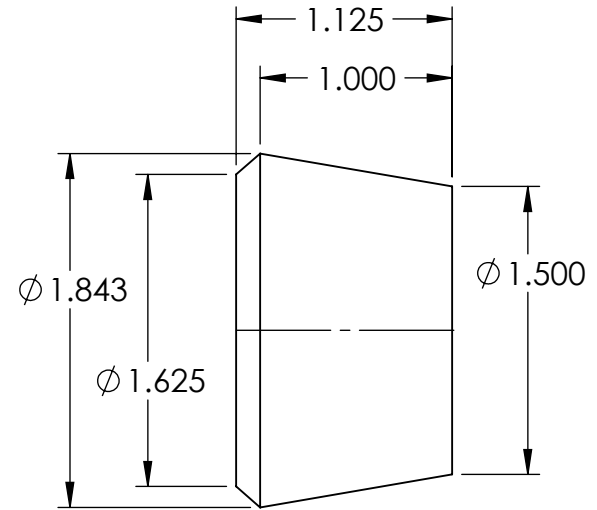

NOTES:

1. FLASH TO BE HELD TO A MINIMUM AND MAY NOT WEB ACROSS HOLES.
2. I.D. AND O.D. CONCENTRICITY .020.
3. ALL OTHER DIMENSIONS  $\pm .015$ .
4. MATERIAL: BLACK NEOPRENE 50-60 DUROMETER
5. REPLACES SRB-35833M

REV.	DATE	CHANGE	UNLESS OTHERWISE SPECIFIED:	NAME	DATE	REMKE INDUSTRIES 310 CHADDICK DR, WHEELING, IL. 60090	
A	11/30/00	DRAWING RELEASED	DIMENSIONS ARE IN INCHES TOLERANCES: FRACTIONAL $\pm 1/64$ ANGULAR: MACH $\pm 1^\circ$ BEND $\pm 1^\circ$ ONE PLACE DECIMAL $\pm .015$ TWO PLACE DECIMAL $\pm .010$ THREE PLACE DECIMAL $\pm .005$	DRAWN	JCN	7/15	TITLE: <b>BUSHING</b>
B	7/16/15	REDRAWN		CHECKED			SIZE <b>A</b>
				ENG APPR.			DWG. NO. <b>SBF-5012</b>
				MFG APPR.			SCALE: 2:1
				Q.A.			SHEET 1 OF 1
			INTERPRET GEOMETRIC TOLERANCING PER:	<b>PROPRIETARY AND CONFIDENTIAL</b> THE INFORMATION CONTAINED IN THIS DRAWING IS THE SOLE PROPERTY OF REMKE INDUSTRIES. ANY REPRODUCTION IN PART OR AS A WHOLE WITHOUT THE WRITTEN PERMISSION OF REMKE INDUSTRIES IS PROHIBITED.			
			MATERIAL <b>SEE NOTE</b>				
			FINISH				
			DO NOT SCALE DRAWING				

5

↑

4

3

2

1