



June | 2026

NZ

# Reid™ Mistake Plate

Compliance Document



Reid™ Mistake  
Plates comply with  
NZ Good Practice  
Guide: Safe Work  
with Precast  
Concrete: 2018

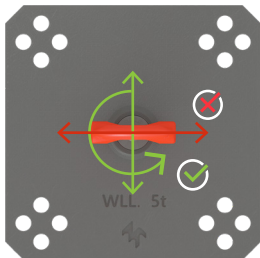
# Reid™ Mistake Plate



Typically used in instances where there has been an error in anchor placement or a failure of the concrete/anchors prior to or during a lift. The design of the MPLATE Mistake Plate with its swiveling head, allows the plate to be loaded in any direction with no impact on capacity.

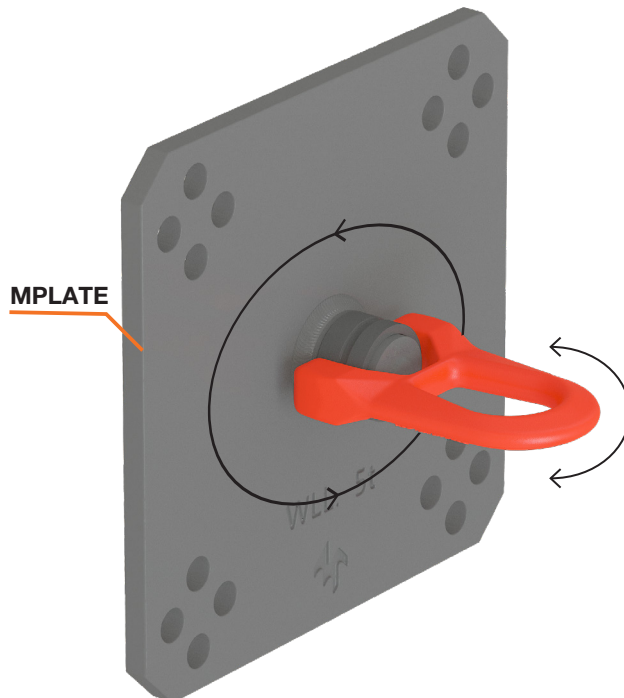


**Figure 1:**  
**Reid™ Mistake Plate**



## Reid™ Mistake Plate Key Features:

- Designed for use where a lifting anchor has been omitted or installed incorrectly in a concrete panel.
- 5 tonne WLL
- Suitable for use with thicknesses of 150mm and above.
- Designed in accordance with NZS3404:1997
- Made in Australia
- NATA Proof Load Certificate
- Lifting Eye has multiple axes of movement which can swivel and rotate to safely manoeuvre during lifting of concrete elements.
- Multiple bolt holes allow greater range for SpaTec Xtrem™ or BraceSet™ Anchor location fixing.

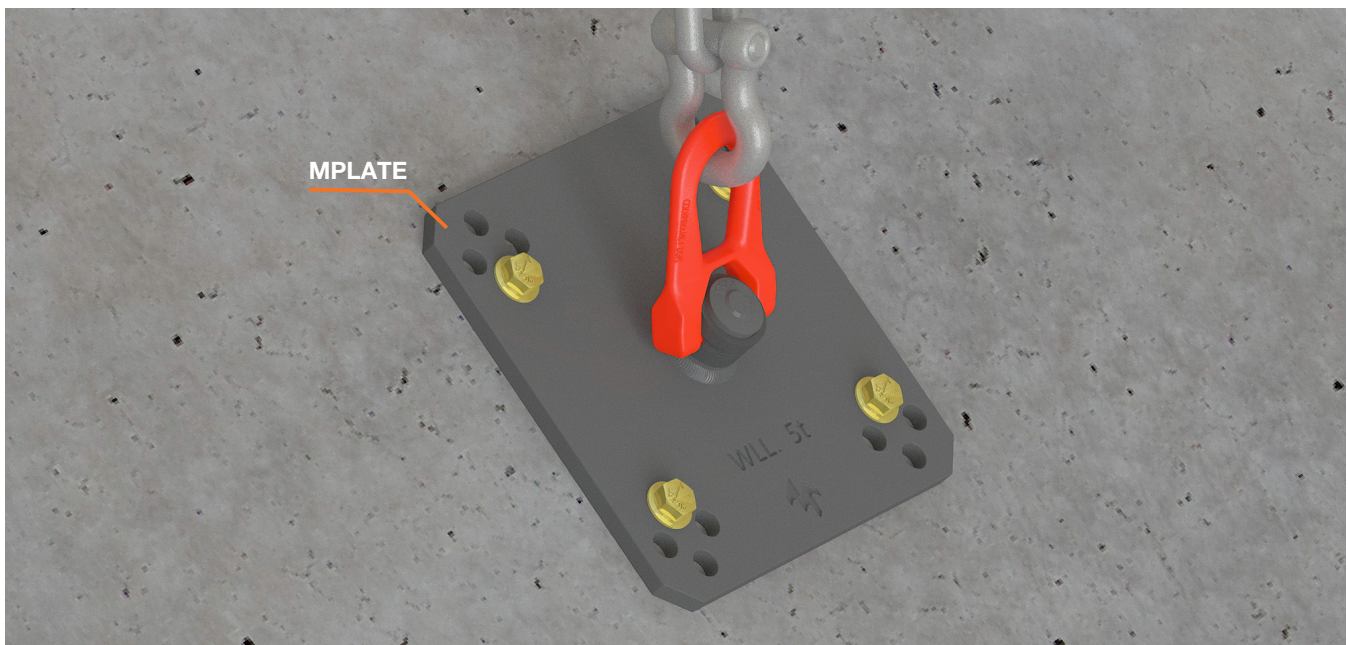


When the shackle is side loaded (incorrect procedure) there is a risk that the shackle will bind resulting in a decline in capacity.

# Compliance Details

Table I: NZ GPG 2018 Compliance Details

Clause	Requirement	Compliant
6.6	The minimum FOS for general lifting needs to be 3.0 and for repetitive lifting needs to be 5.0.	
6.6	The design of the Lifting anchor shall include the ductile behavior and robustness of the anchor.	
10.11	Lifting clutches are to be made in accordance with a valid international standard or technical reference.	
10.11	Every item of lifting equipment should be clearly and permanently marked with its WLL. A unique numbering system to clearly identify individual items should be used.	
10.11	Lifting clutches are to be tested for loads in all directions and initially tested by the supplier to a factor of safety of 2.0	
10.11	Inspected at least every 12 months by a competent person, and a record kept of those inspections.	



Designed in accordance with **NZS3404:1997**



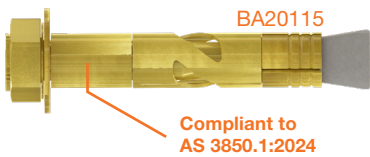
# Product Specification



Reid™ Mistake Plates are typically used in instances where there has been an error in anchor placement or an anchor that has been deemed unfit for use.

## Requires 4x BraceSet™

(Product Code: BA20115) for installation into concrete.



Go to [www.reids.co.nz](http://www.reids.co.nz) for a copy of the BraceSet AS3850.1:2024 compliance document.

## or 4x SpaTec™ Xtrem™

(Product Code: SP12120) for installation into concrete.



Go to [www.ramset.co.nz](http://www.ramset.co.nz) for a copy of the SpaTec Xtrem™ Safety Anchors product information document.

## Working Load Limit

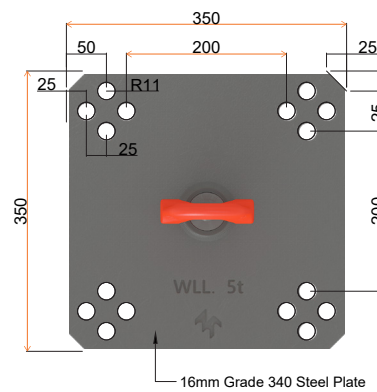
The Reid™ Mistake Plate is marked with its rated Working Load Limit of 5t @20 MPa (when positioned away from an edge, and when the lift design is certified by the Reid™ Engineering

### Please note:

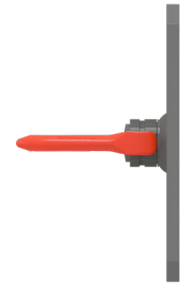
The MPLATE with a swiveling head can be loaded in any direction whilst maintaining its full 5t WLL. Older version MPLATE without a swiveling head cannot.

## Dimensions (mm)

View 1



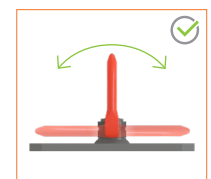
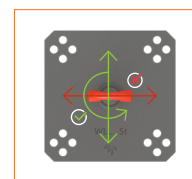
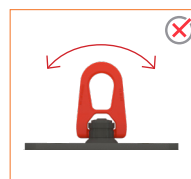
View 2



Note: All plates contain a unique serial number etched onto the plate, located near branding.

## Load Direction

Shackle must be positioned in the direction of the load.



# Installation Instructions

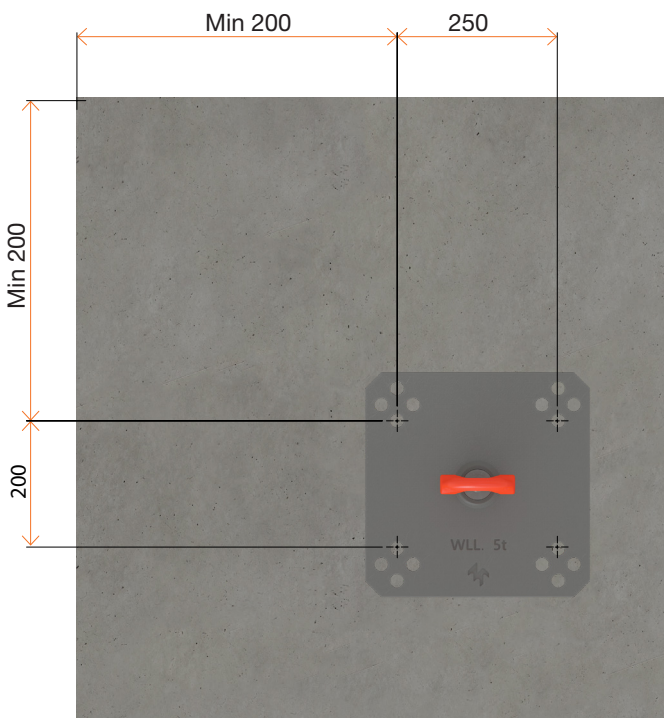
## Product Code

Product Code	Description	Capacity
MPLATE	Reid Mistake Plates	5 Tonne

### Please note:

Requires 4x BraceSet™ anchors (Product Code: BA20115) or 4x SpaTec™ Xtrem™ anchors (Product Code: SP12120) installed as per the installation procedure illustrated further below.

## Minimum Edge Distances (mm)



### Please note:

It is critical that there are 200mm minimum edge distances for the MPLATE.

## Installation Specification

Anchor	Part No.	Drill Hole Diameter (mm)	Hole Depth (mm)	Set up Torque (Nm)	Min. Edge Distance (mm)	Min. Ctr Distance to another plate (mm)	Min. Concrete Strength (MPa)
BraceSet™	BA20115	20	130***	150	200	750*	>20**
SpaTec™ Xtrem™	SP12120	18	116***	80			

**Note:** Minimum concrete panel thickness 150mm

\*750mm or as specified by Reid™ engineer.

\*\*Ensure that the minimum concrete strength achieved is more than 20 MPa

\*\*\*Hole to be thoroughly cleaned - dust blown out/vacuumed

## Installation Instructions



1. Centralise the MPLATE at proposed lifting point, with specified minimum distances from concrete edge and another plate.

2. Drill one hole for each corner with nominated diameter and depth.

3. Blow/vacuum dust from the hole.

4. Position and drive the anchor with mash hammer into hole until it makes contact with the lifting plate.

5. Tighten the anchor bolts with a calibrated torque wrench to the nominated assembly torque\*.

\*Use calibrated torque wrench to verify the required installation torque, in accordance with AS 3850.2:2024 clause 5.1.2.

**Note:** If reinforcing is struck and the required depth cannot be achieved, please follow the Aborted Hole Process on page 6.

Prior to each use, ensure red tab & swivel rotates freely and does not catch or snag.

# Aborted Hole Process

If reinforcing is struck and the required depth cannot be achieved, the following process shall be followed:

**Case 1 – for Mistake Plate subject to rotation experiencing multi-directional shear (e.g. rotation of precast panels)**

1. Aborted hole must be filled with high strength grout/mortar. Grout/mortar strength should be equivalent or greater than concrete strength at time of lift.
2. Mistake Plate shall be relocated 100mm in any direction from original position (maintaining the minimum edge distances), redrill the holes.

**Case 2 – for Mistake Plate subject to one direction shear (e.g. tilt-up panels being lifted with spreader beams)**

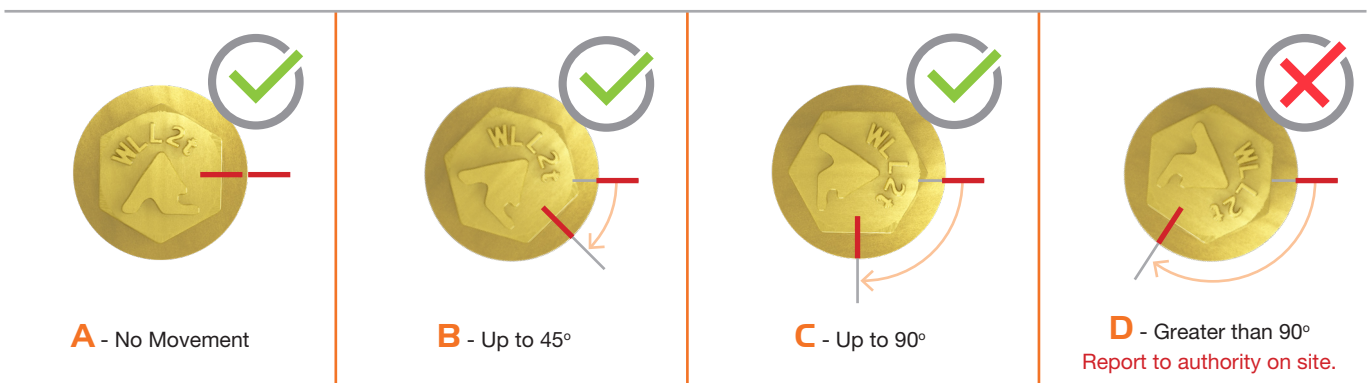
1. Aborted hole may be discarded provided it is not in direct line of the lifting load. If unsure, always fill aborted hole with high strength grout/mortar.
2. Mistake Plate shall be relocated 100mm to the left or right side from original position (maintaining the minimum edge distances), redrill the holes.

Alternatively for Case 2 only, if the aborted hole is less than 46 mm deep, you can use another hole in the plate provided the aborted hole is filled with high strength grout/mortar and you maintain the required minimum edge distance and plate spacings.

Note 1: Where required all aborted holes must be filled with high strength grout/mortar (e.g. Ramset™ Poziflo, Ramset™ EPCON G5 Xtrem or similar).  
 Note 2: Where aborted holes are filled, the aged strength of grout/mortar shall be at least the strength of the concrete at time of lift.

# Installation QA Check

1. Anchor bolts should be verified at least weekly and after major weather events to ensure they are secure, in accordance with AS3850.2:2024
2. Check if a bolt head can be turned by hand and if it turns, report it immediately to the responsible authority on site.
3. After installation of anchors with nominated assembly torque, put an alignment reference mark on the bolt head and the surrounding surface.
4. For BraceSet™, using calibrated torque wrench, apply 100Nm torque in a clockwise direction.  
 For SpaTec Xtrem™, using a calibrated torque wrench, apply 54Nm torque in a clockwise direction.

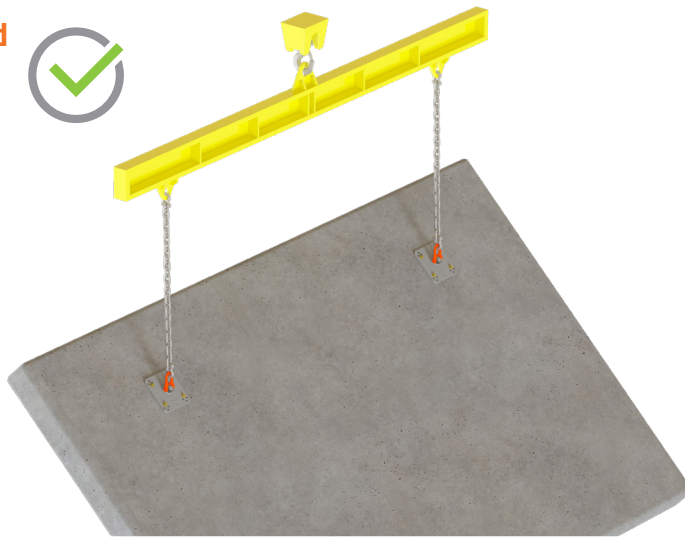


5. If any anchor bolt turns more than 90° from the reference mark, then report this immediately to the responsible authority on site.
6. Total accumulated rotation of any bolt head should not exceed 180° from the first reference mark and if it does, report immediately to the responsible authority on site.
7. Reid™ does not recommend retorquing to the initial installation torque of 150Nm for BraceSet™ of 150Nm or for SpaTec Xtrem™ of 80Nm.

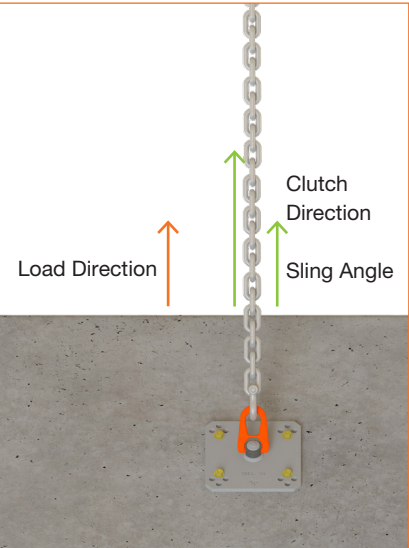
# Safe Lifting Procedures

All uses of MPLATE should follow an engineered Lifting Certification

**Preferred Lifting Practice**

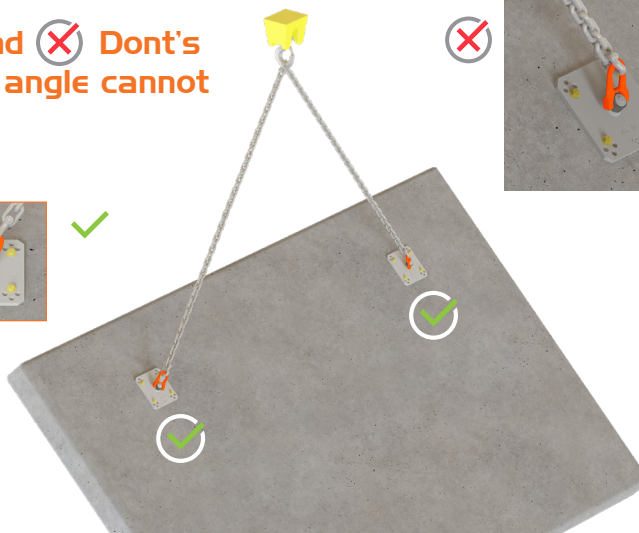


Using a spreader beam is best practice for optimal weight distribution when lifting points are at the top of the panel.



MPLATE shackle (red tab) must be positioned in the direction of the load. If rotation is to take place, the swivel will allow the shackle to rotate through the lift.

**Do's** **and** **Dont's** **when sling angle cannot be avoided**

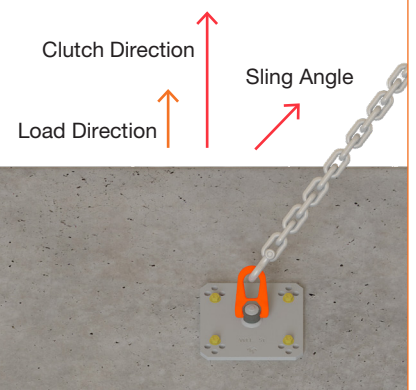


If a shear load is applied to a MPLATE where the lifting swivel cannot rotate, the applied load is increased on the lifting point; increasing the risk of injury or panel damage.

**Incorrect Lifting Practice**



It is incorrect if swivel arm is not aligned with sling angle.



When the shackle is side loaded (incorrect procedure) there is a risk that the shackle will bind resulting in a decline in capacity.

**Please note:**

The MPLATE with a swiveling head can be loaded in any direction whilst maintaining its full 5t WLL as long as the articulating clutch/head is pointed in the correct direction by aligning with the load direction.

# Maintenance, Inspection and Discard Criteria

Below guide outlines required maintenance, inspection procedures, and serviceability thresholds for Reid™ MPLATE mistake plates.

This information assists users in identifying when equipment must be removed from service to ensure safe and compliant operation.



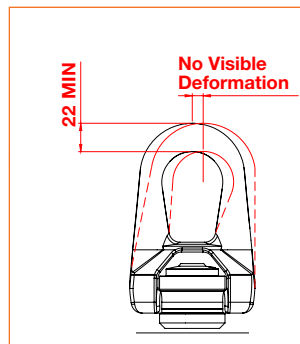
## Maintenance Requirements

- Remove all concrete buildup, particularly around the four baseplate holes and underside contact surfaces.
- Lubricate the swivel mechanism using a high-pressure-resistant, partially synthetic oil (e.g., Würth HHS 2000 or equivalent).
- Confirm that the plate rotates freely following lubrication and that all moving components operate smoothly.



## Inspection Requirements

- Ensure the plate is free from concrete buildup.
- Check for cracks, deformation, or any visible signs of damage.
- Inspect the handle for distortion or evidence of overloading.
- Examine welds for gaps, cracking.
- Assess the plate for bending, warping, or loss of flatness.
- Inspect the four baseplate holes for damage and excess wear.
- Test the rotation mechanism to ensure smooth movement without sticking or binding.
- Confirm that the handle moves correctly without jamming.



## Discard Criteria

Remove the lifting plate from service immediately if any of the following conditions are present:

- Welds exhibit gaps, cracking, or structural failure.
- The plate shows bending or deformation that compromises safe seating, load distribution, or operational integrity.
- The rotation mechanism (swivel) does not rotate smoothly or is locked up.
- Any sign of grinding and/or acetylene cutting.



# Terms and Conditions

---

**Important Disclaimer: Any engineering information or advice (“Information”) provided by Reid® in this document is issued in accordance with a prescribed standard, published performance data or design software. It is the responsibility of the user to obtain its own independent engineering (or other) advice to assess the suitability of the Information for its own requirements. To the extent permitted by law, reid will not be liable to the recipient or any third party for any direct or indirect loss or liability arising out of, or in connection with, the Information.**







## Customer Service

### Reid™ New Zealand

Tel: 0800 88 22 12

Email: [sales@ramsetreid.co.nz](mailto:sales@ramsetreid.co.nz)

Web: [www.reids.co.nz](http://www.reids.co.nz)

#### Reid™

NZ: 23-29 Poland Road, Glenfield, Auckland 0632

Information in this document is correct at the time of printing. Readers should contact Reid™ or consult Reid™ detailed technical information to ensure product is suitable for intended use prior to purchase. ITW Australia Pty Ltd ABN 63 004 235 063 trading as Reid™ © copyright 2026. ™ ™ Trademarks of Illinois Tool Works Inc used under license by Reid™

**Important Disclaimer:** Any engineering information or advice ("Information") provided by Reid™ in this document is issued in accordance with a prescribed standard, published performance data or design software. It is the responsibility of the user to obtain its own independent engineering (or other) advice to assess the suitability of the Information for its own requirements. To the extent permitted by law, Reid™ will not be liable to the recipient or any third party for any direct or indirect loss or liability arising out of, or in connection with, the Information. None of the products listed in this document are subject to a warning or ban under the Building Act 2004.

