

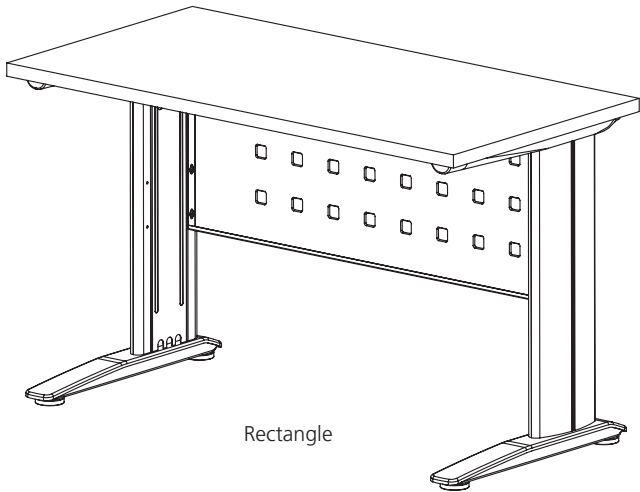

R-Style Modesty Panel (RCM) & Teacher CSW Assembly Instructions

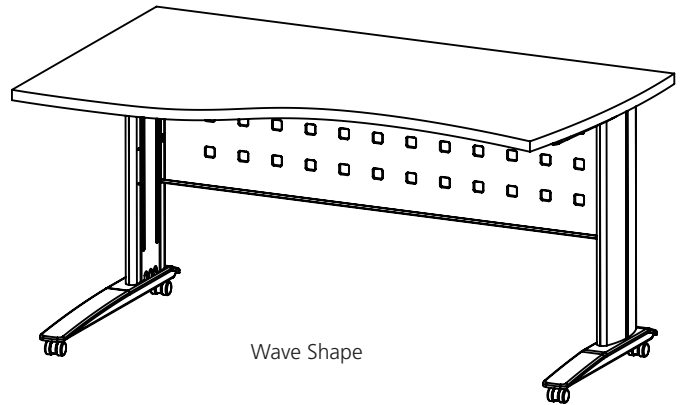

Rectangle



Wave Shape

R-Style Beam Assembly Instructions (RCB): Pages 4 - 6

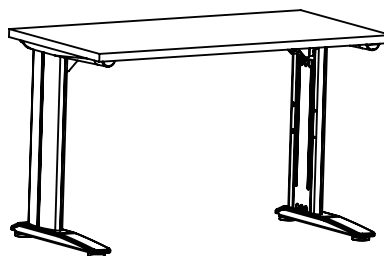

Caster Assembly Instructions: Page 7

Tools Required for Assembly

- A. Power Driver with Adjustable Torque
- B. #2 Phillips Head Driver Bit
- C. #2 Square Head Drive Bit

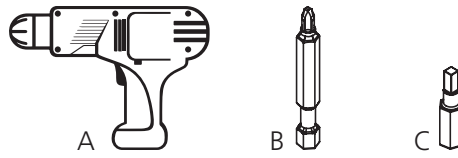

Hardware Included for Assembly (may have extra)

- D. M6 x 1/2" Phillis Machine Screw x6
- E. 10 X 5/8" Round Washer Head Recex Drive Screw x9



Step 1

- With each leg upside down, attach the modesty panel to the legs with six machine screws.
- If base is connecting to a wave shaped top, you will have one leg with a longer foot and one leg with a shorter foot.

The longer foot must match the deeper side of the worksurface. See image below for reference.

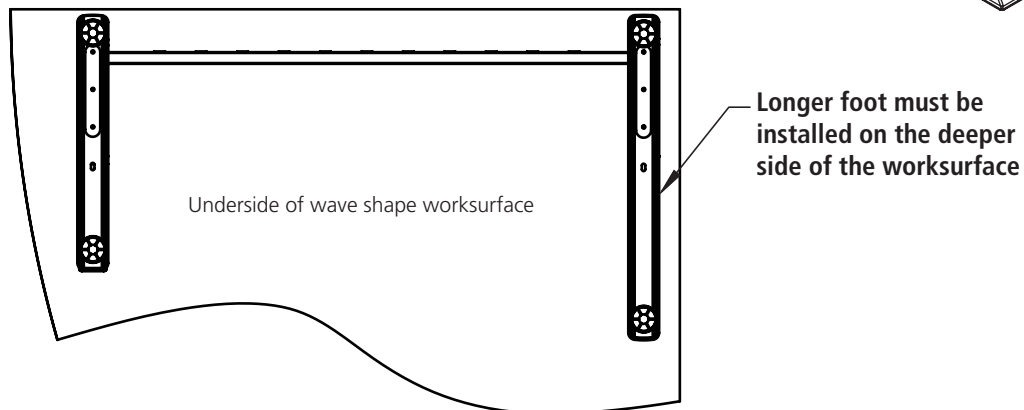
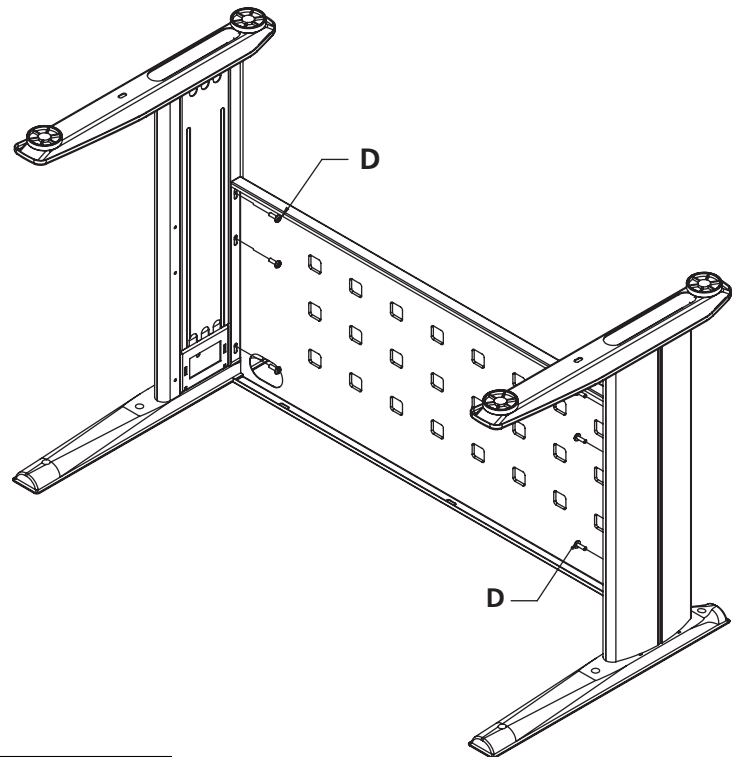
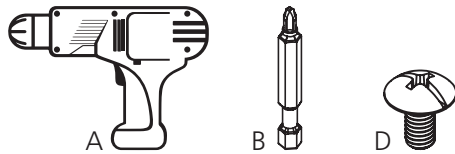

Step 2

- Carefully place the worksurface on a protected surface and pre-drilled pilot holes facing upwards.
- Place the desk base onto the worksurface, and align the legs with the pilot holes on the worksurface.
- Attach the modesty panel and legs to the worksurface with the wood screws.

Note: there are no pilot holes in the worksurface for the modesty panel attachment. Pre-drilling is not required.

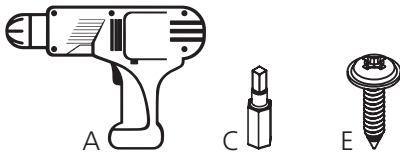
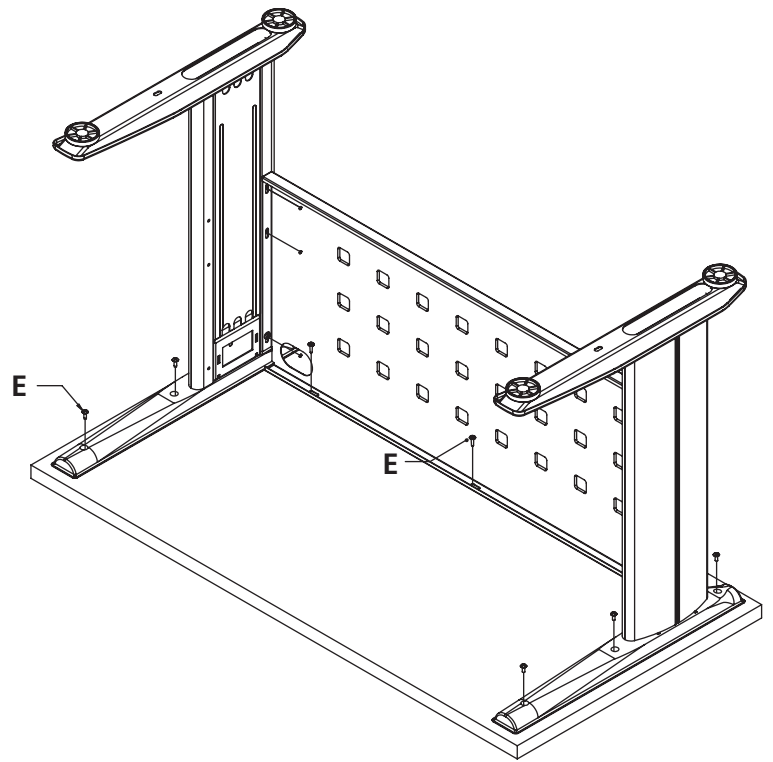

If you have optional threaded inserts in your worksurface, refer to the insert instruction #54134.



R-Style Beam Assembly Instructions (RCB)

Warranty: raproducts.com/warranty

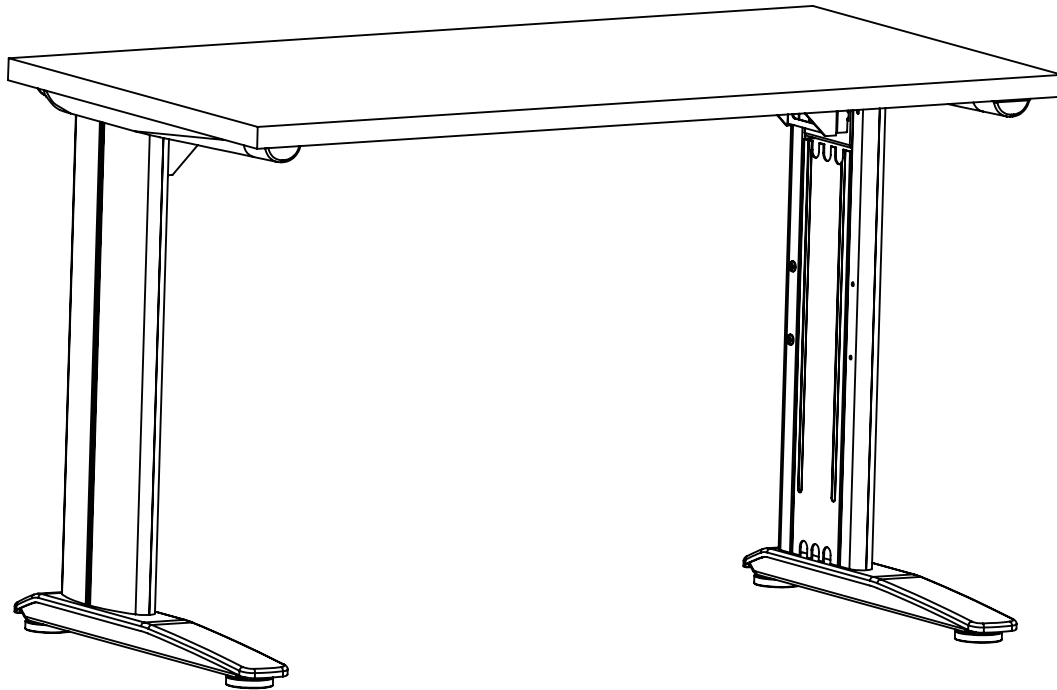

R-Style Modesty Panel Instructions (RCM): *Pages 1 - 3*

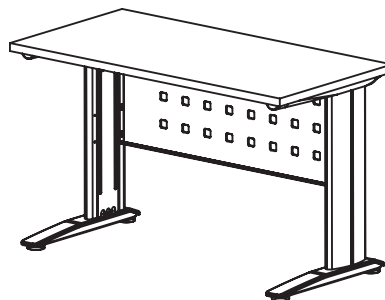

Tools Required for Assembly

- A. Power Driver with Adjustable Torque
- B. #2 Phillips Head Driver Bit
- C. #2 Square Head Drive Bit
- D. Level

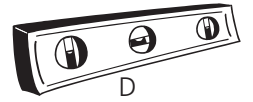
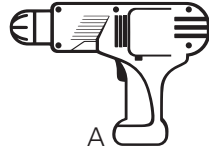

Hardware Included for Assembly (may have extra)

- E. M6 x 1/2" Machine Screw x4
- F. 10 x 5/8" Round Washer Wood Screw x6
- G. 3/16" x 3/4" Wood Screw x3
- H. M6 x 9/16" Black Machine Screw x2
- I. 5/64" x 1 3/8" Plate x2

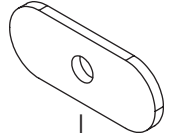
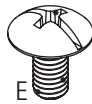

Step 1

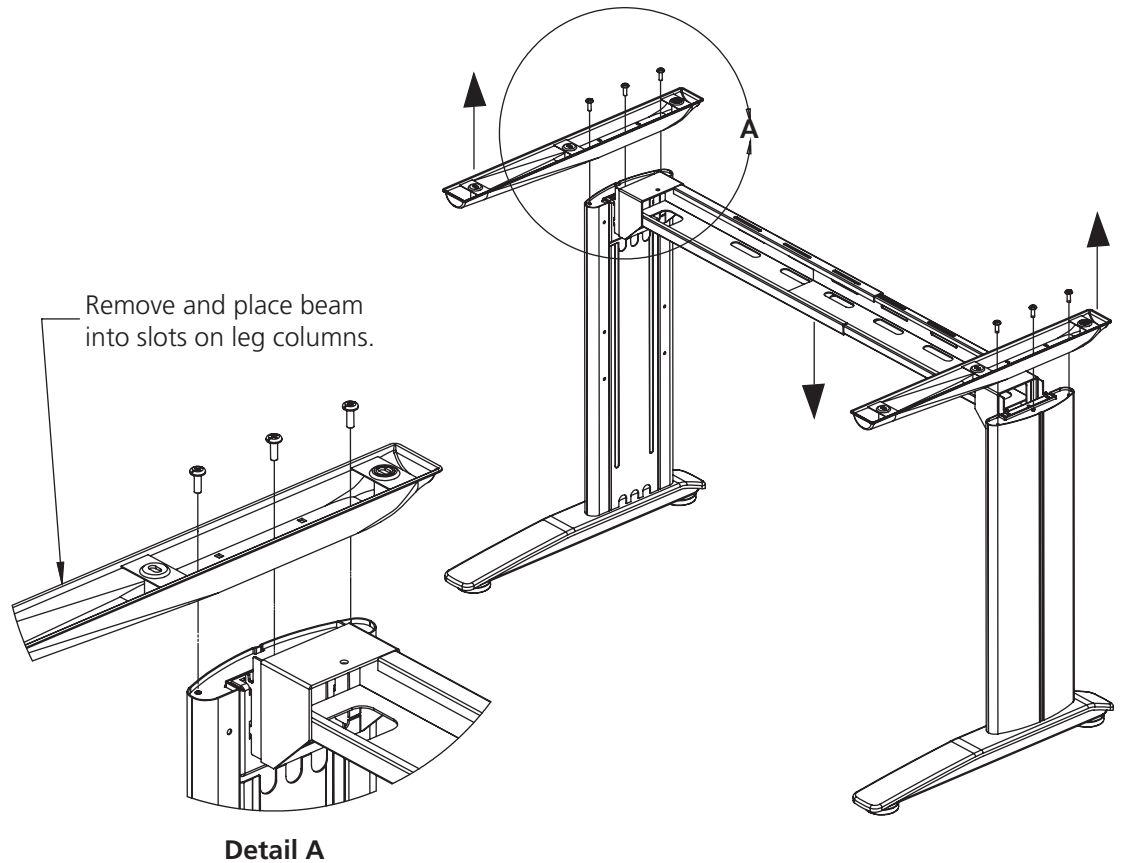
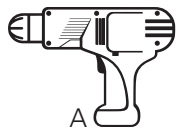

Step 2

- Install wood screws.
- Install machine screws and plate for final adjustment.

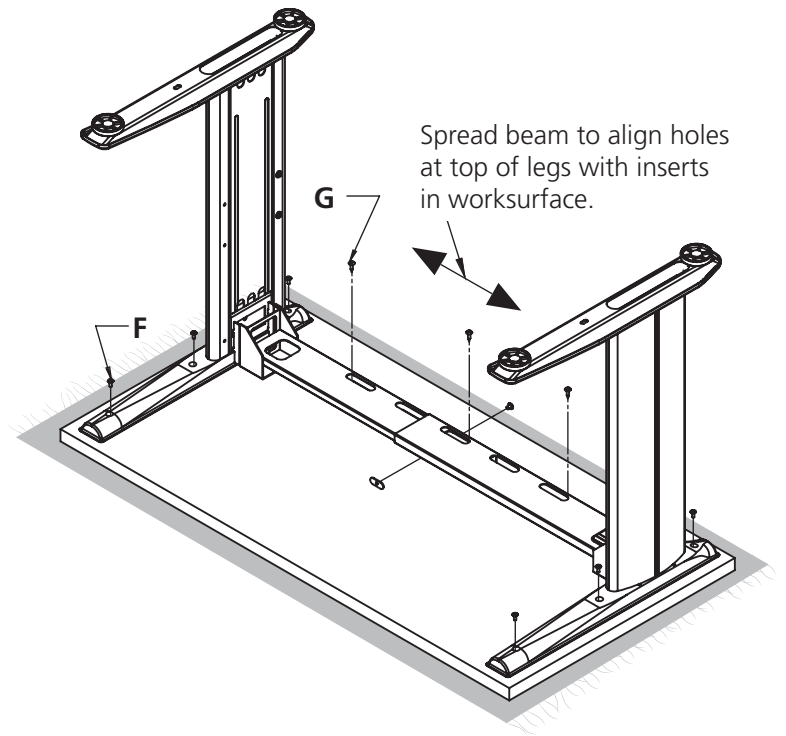
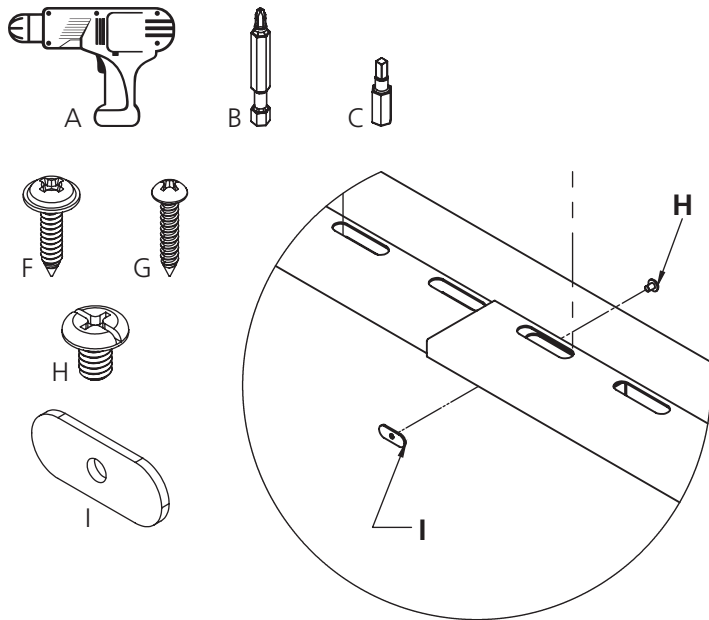

Step 3 Optional Stability Panel

- Install the machine screws into the legs and panel hardware.

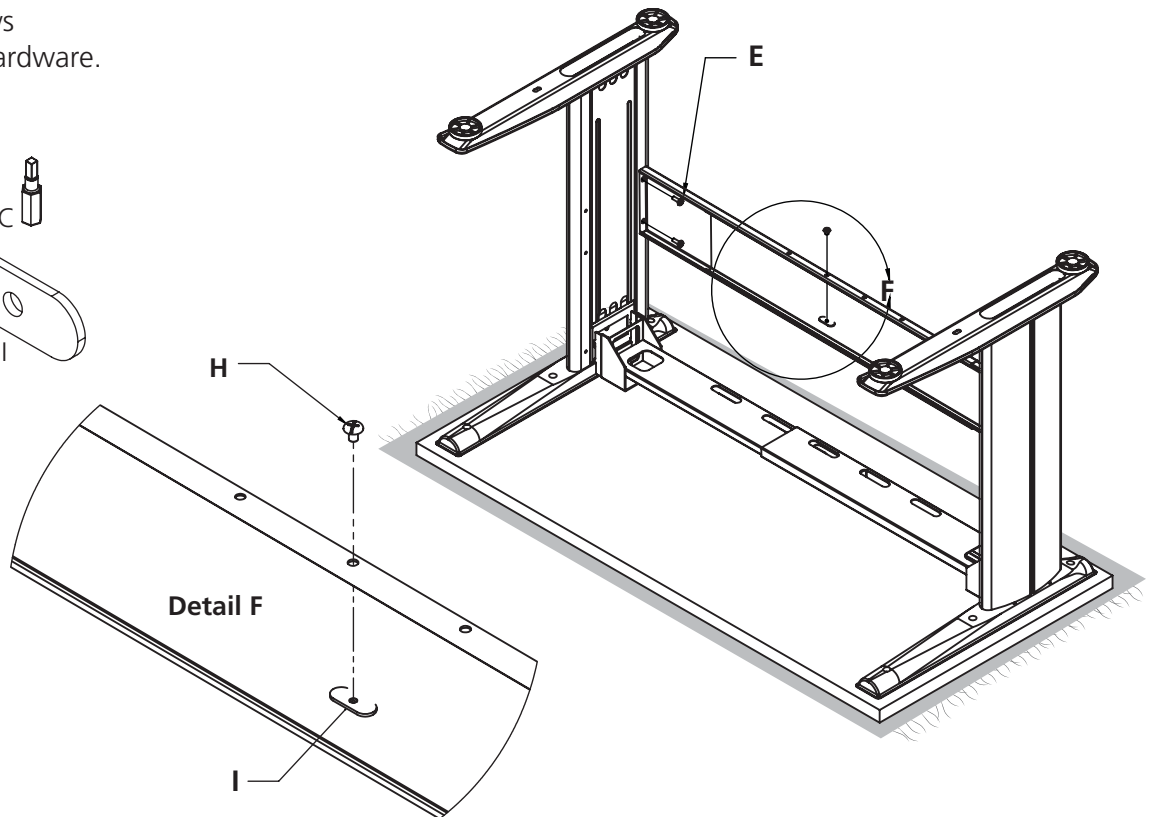
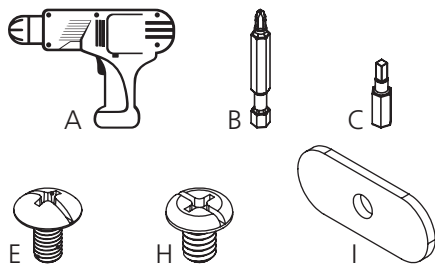

If you have optional threaded inserts in your worksurface, refer to the insert instruction #54134.

R-Style Caster Install Instructions #54064

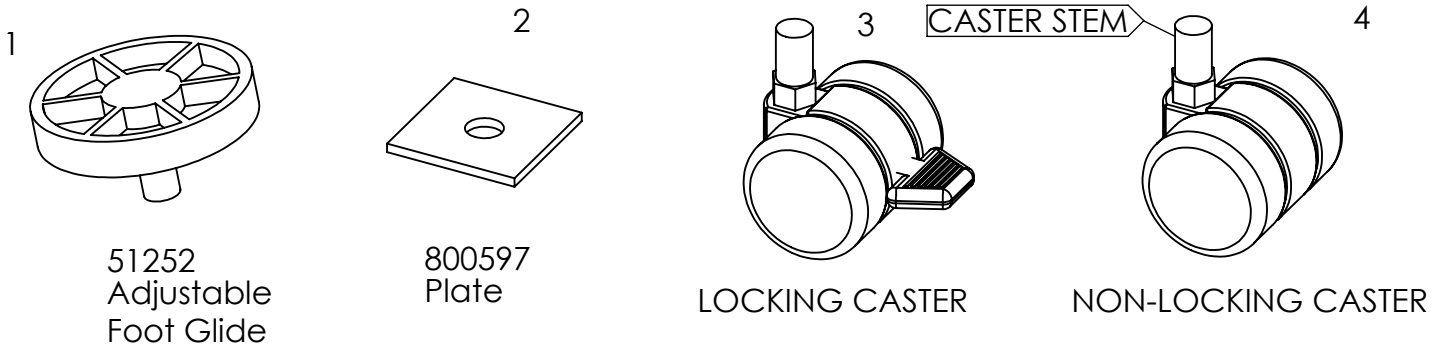

Remove the two adjustable feet glides on each desk leg by turning them counter clockwise.

Place the 800597 Plates onto the casters stems. Install casters into the foot by turning them on clockwise.

The locking caster should be put on the front side (user side) of the leg.

