

NEBO[®]

CERTIFIED INTRINSICALLY SAFE

Alliance Consumer Group
5650 Alliance Gateway Freeway
Fort Worth, TX 76177
800-866-5051
www.nebotools.com

USER MANUAL
MODEL 6757

Certified Intrinsically Safe Industrial Flashlight
For Use in Hazardous Locations

USER MANUAL

Model:
6757

What is a Safety Rated flashlight?

In some working environments, flashlights are needed that can be safely operated when explosive gases, liquids, dusts, or fibers are present. Flashlights that have been certified as intrinsically safe are designed in such a way that they will not be a source of ignition in those hazardous environments.

NEBO®

GAS: CI, D1, GRP ABCD, T4

DUST: CII, D1, GRP EFG, T4

These flashlights are generally tested by a certification group such as CSA or UL. The rating system is composed of the following:

- » Classes: identifies the type of hazardous material present.
- » Divisions: designates the probability that an ignitable concentration of that material is present.
- » Groups: identifies the elements that are present that have the potential to cause and explosion.
- » Temp Codes: lists the maximum surface are temperature of the equipment.

Features:

- Intrinsically safe for use in hazardous locations
- High and Low mode functions
- High power CREE LED
- Focus and flood reflector
- Waterproof (IP67)
- Tough and durable casing
- Screw fastener for safety precautions
- Build-in gas release vent

Operation:

Push the top button to operate. The sequence is high and then low.

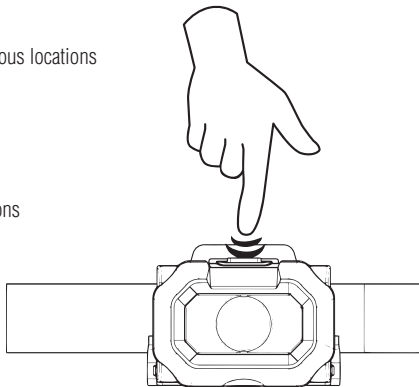

Battery Replacement:

Use only battery types below:
Alkaline type
Energizer E92
Duracell MN2400
Panasonic AAA LR03

Warning: Do not open in hazardous locations.

Warning: To reduce the risk of explosion do not mix new batteries with used batteries, or mix batteries from different manufacturers or from different types.

Warning: Remove the batteries when unused for a period of time to prevent battery leakage in the device.

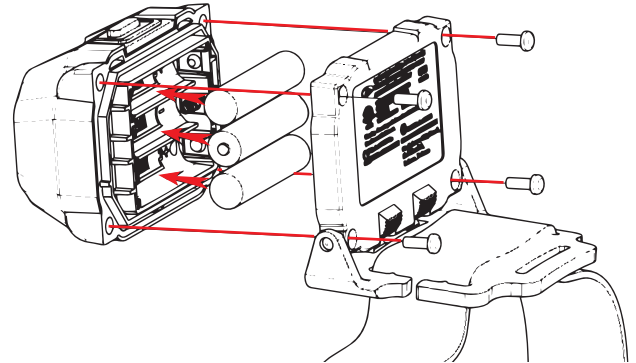

Safety Warnings:

1. The screw shall be secured tightly after opening and closing of the enclosure.
2. Substitution of components may impair intrinsic safety.
3. Clean the flashlight only with damp cloth to avoid static electricity.
4. Bright light: Avoid direct eye exposure.
5. Always use the device following the regulations of each country.

SÉCURITÉ INTRINSÈQUE:

1. AVERTISSEMENT : LA SUBSTITUTION DE COMPOSANTS PEUT COMPROMETTRE LA SÉCURITÉ INTRINSÈQUE.
2. AVERTISSEMENT : AFIN DE PRÉVENIR L'INFLAMMATION D'ATMOSPHÈRES DANGEREUSES, NE CHANGER LES BATTERIES QUE DANS DES EMPLACEMENTS DÉSIGNÉS NON DANGEREUX.

Certifications:

	CLASS I DIV 1&2 GRP ABCD CLASS II DIV 1&2 GRP EFG CLASS III TEMP CODE: T4 IP67 FILE NUMBER: E503043
	CE 0518

What's Included:
- Adjustable head strap

Warranty:
1 years
Limited Warranty

Standards:

1. UL 913, Seventh Edition
2. CSA C22.2 No.157-92, Reaffirmed 2012