

Ø 5.36
BODY

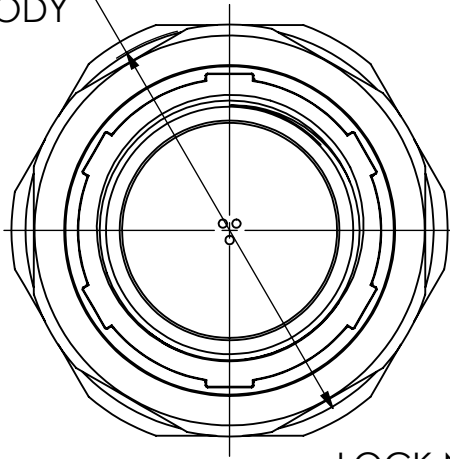

LOCK NUT
OPTIONAL
ADD: L

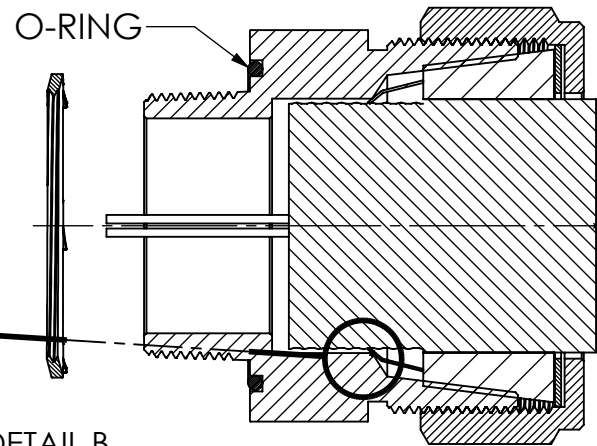
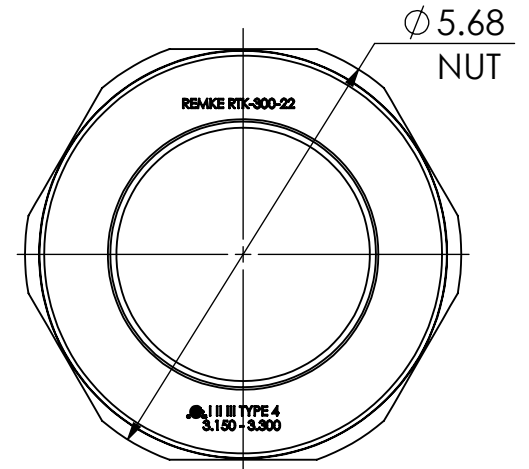
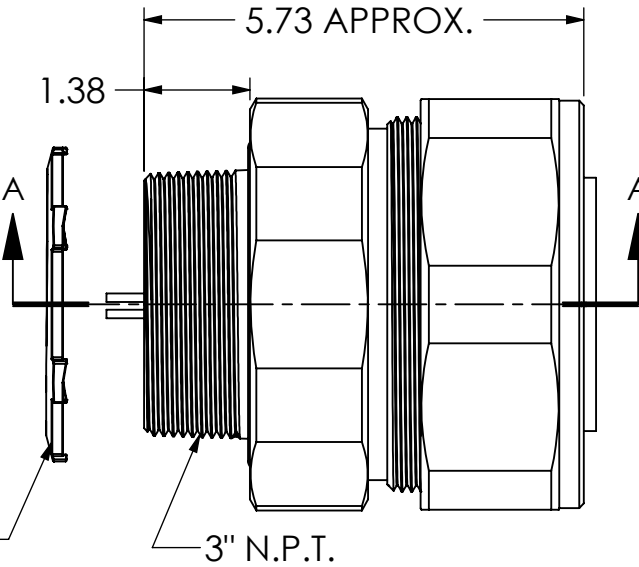

DETAIL B
SCALE 1.5 : 1

SECTION A-A

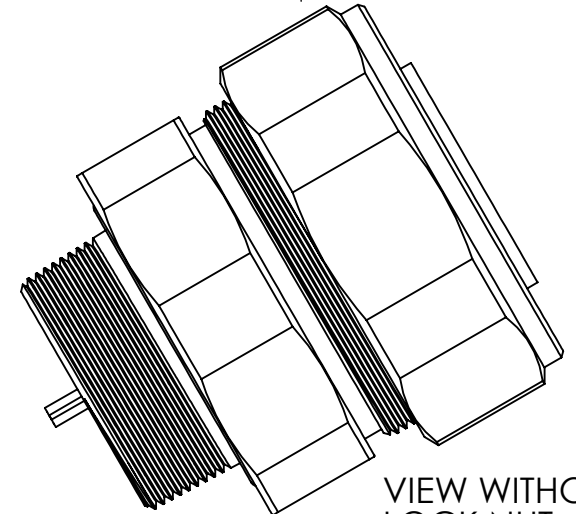

VIEW WITHOUT
LOCK NUT



REV.	DATE	CHANGE	UNLESS OTHERWISE SPECIFIED:	NAME	DATE	REMKE REMKE INDUSTRIES 310 CHADDICK DR, WHEELING, IL. 60090	
A	12/2/13	DRAWING RELEASED	DIMENSIONS ARE IN INCHES TOLERANCES: FRACTIONAL ± 1/64 ANGULAR: MACH ± 1° BEND ± 1° ONE PLACE DECIMAL ± .015 TWO PLACE DECIMAL ± .010 THREE PLACE DECIMAL ± .005	DRAWN JCN	12/13	TITLE:	
			INTERPRET GEOMETRIC TOLERANCING PER:	CHECKED		SIZE DWG. NO.	
			MATERIAL ALUMINUM	ENG APPR.		A RTK-300-22	
			FINISH	MFG APPR.		SCALE: 1:2	
			DO NOT SCALE DRAWING	Q.A.		SHEET 1 OF 1	
				PROPRIETARY AND CONFIDENTIAL THE INFORMATION CONTAINED IN THIS DRAWING IS THE SOLE PROPERTY OF REMKE INDUSTRIES. ANY REPRODUCTION IN PART OR AS A WHOLE WITHOUT THE WRITTEN PERMISSION OF REMKE INDUSTRIES IS PROHIBITED.			