





# Deer Fence Heavy Duty End Post Installation Instructions

**Note:** If a tension system was purchased, please refer to tensioning kit instructions **BEFORE** these instructions.

## HARDWARE PARTS – DE90401

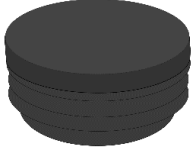
|                                                                                                                                                                                                                 |                                                                                                                                                                                                                 |                                                                                                                                                                                                                      |                                                                                                                                                                                                 |
|-----------------------------------------------------------------------------------------------------------------------------------------------------------------------------------------------------------------|-----------------------------------------------------------------------------------------------------------------------------------------------------------------------------------------------------------------|----------------------------------------------------------------------------------------------------------------------------------------------------------------------------------------------------------------------|-------------------------------------------------------------------------------------------------------------------------------------------------------------------------------------------------|
| <p><b>A</b></p> <p>QTY: 2</p>  <p>1 5/8" Brace Cup Black<br/>SKU: DE8144</p>                                                   | <p><b>B</b></p> <p>QTY: 2</p>  <p>2 1/2" Brace Band Black<br/>SKU: DE8084</p>                                                  | <p><b>C</b></p> <p>QTY: 2</p>  <p>Carriage Bolt w/Washer &amp; Nut<br/>Hot Dip Galvanized - 5/16" x<br/>1 1/2"<br/>SKU: DE8042</p> | <p><b>D</b></p> <p>QTY: 2</p>  <p>2 1/2" Black Vinyl Post Cap<br/>SKU: DE8091</p>                            |
| <p><b>E</b></p> <p>QTY: 2</p>  <p>17 Gauge 2 1/2" Black Powder<br/>Coated Galvanized Pipe<br/>(See below for measurements)</p> | <p><b>F</b></p> <p>QTY: 2</p>  <p>17 Gauge 1 5/8" Black Powder<br/>Coated Galvanized Pipe<br/>(See below for measurements)</p> | <p><b>G</b></p> <p>QTY: 4</p>  <p>Self-Tapping Screw 3/8"<br/>SKU: DE9978-1</p>                                                    | <p><b>H</b></p> <p>QTY: 2 (Only included for 8' – 7')</p>  <p>2 1/2" x 24" End Extension<br/>SKU: DE8166</p> |

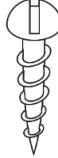
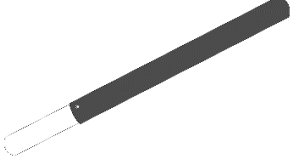
### Recommended Tools (not included)

Power Drill with 5/16" Drill Bit

Socket Wrench 5/16" or Adjustable wrenches

Shovel/Post Hole Digger

Concrete/Expanding Post Foam

## Pipes Part List

|                  | 8' End   |                                                                  |            | 7' End |                                                                 |            |
|------------------|----------|------------------------------------------------------------------|------------|--------|-----------------------------------------------------------------|------------|
|                  | Qty      | Pipe Measurement                                                 | SKU        | Qty    | Pipe Measurement                                                | SKU        |
| Corner Posts (E) | 2        | 17 Gauge Black Powder Coated Galvanized Pipe 2 1/2" x 108"       | DE8362-108 | 2      | 17 Gauge Black Powder Coated Galvanized Pipe 2 1/2" x 96"       | DE8362-096 |
| Brace Posts (F)  | 2        | 17 Gauge Black Powder Coated Galvanized Steel Pipe 1 5/8" x 108" | DE8358-108 | 2      | 17 Gauge Black Powder Coated Galvanized Steel Pipe 1 5/8" x 96" | DE8358-096 |
|                  | 7.5' End |                                                                  |            | 6' End |                                                                 |            |
|                  | Qty      | Pipe Measurement                                                 | SKU        | Qty    | Pipe Measurement                                                | SKU        |
| Corner Posts (E) | 2        | 17 Gauge Black Powder Coated Galvanized Pipe 2 1/2" x 108"       | DE8362-108 | 2      | 17 Gauge Black Powder Coated Galvanized Pipe 2 1/2" x 108"      | DE8362-108 |
| Brace Posts (F)  | 2        | 17 Gauge Black Powder Coated Galvanized Steel Pipe 1 5/8" x 108" | DE8358-108 | 2      | 17 Gauge Black Powder Coated Galvanized Steel Pipe 1 5/8" x 84" | DE8358-084 |

# Deer Fence Heavy Duty End Post Installation Instructions

1. Lay out your fence design, taking care to note where your ends are going to be placed within the system.

**Note:** Ends should be placed anywhere the fence is terminating. Either against an existing structure like a house/shed or another fence line.

1.

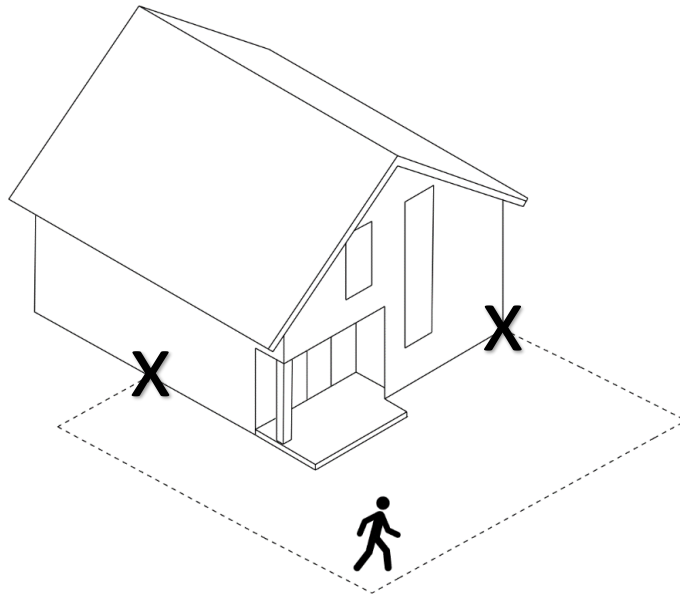

2. **For 8' – 7' Ends:** Insert **END EXTENSION (H)** the silver part into each **END POST (E)**. Secure the extension with **two (2) SELF-TAPPING SCREWS (G)**.

Place the **POST CAP (D)** into each **END POST (E)**. Then using a shovel or post hole digger, create a hole for the **END POST (E)**. Each hole should be **12" WIDE** and **36" DEEP\***. Drop the **END POST (E)**, open end down, into the hole and then set with concrete. Make sure to allow the concrete to set completely before proceeding to **STEP 3**.

**Note:** It is **HIGHLY** recommended to set your posts into concrete. Setting the posts in concrete will strengthen the overall fence system and increase the longevity of the fence. Alternatively, you can use expanding post foam or backfill with rocky dirt and tamp firmly.

2.

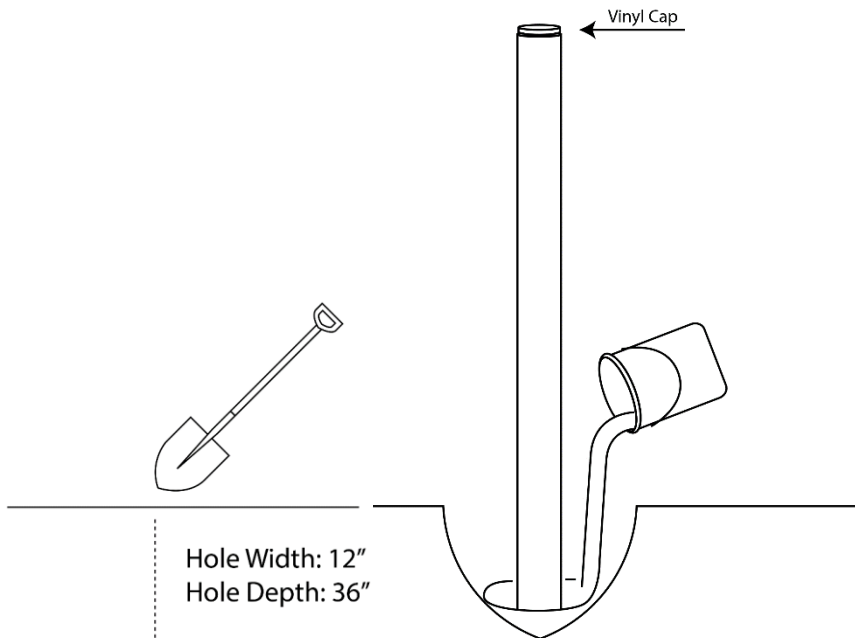
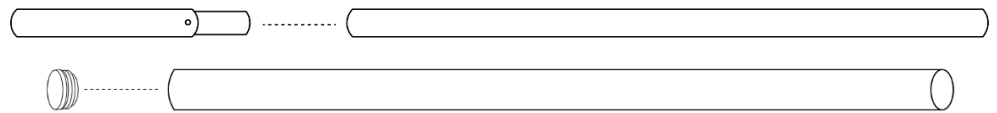

## \*NOTICE – 7.5' END SYSTEM ONLY

These holes should be dug to 42", to accommodate size of corner post plus extender. Should you be unable to do so, a 36" hole will still function, with your end sitting slightly higher than your fence line.

3. Slip **BRACE BAND (B)** and **BRACE CUP (A)** over the **END POST (E)** and position them approximately 12" from the top of the **END POST (E)**. When attaching the **BRACE CUP (A)** to the **BRACE BAND (B)**, position the cup so that the **BRACE POST (F)** will be on the **INSIDE** of the fence line. Use **CARRIAGE BOLT (C)** to hold the **BRACE BAND (B)** and **BRACE CUP (A)** in position. Do not fully tighten.

3.

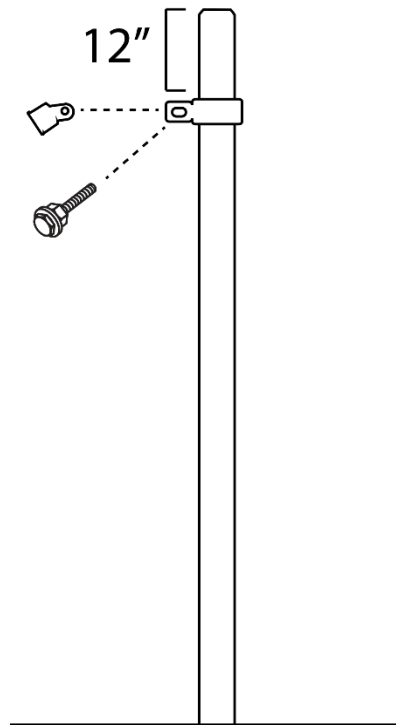

1. After the band is installed, place your **BRACE POST (F)** into the **BRACE CUP (A)** just inside the fence line. At the point where the post meets the ground, you will want to dig a hole approximately, 1' deep. Set the **BRACE POST (F)** into the hole and use a dead man brace to secure the post.

**Note:** A dead man brace is a brace put into the ground to hold the brace post in position. You can use a cinderblock or a large sturdy piece of wood as the dead man. Alternatively, you can cement the brace post if you choose.

4.

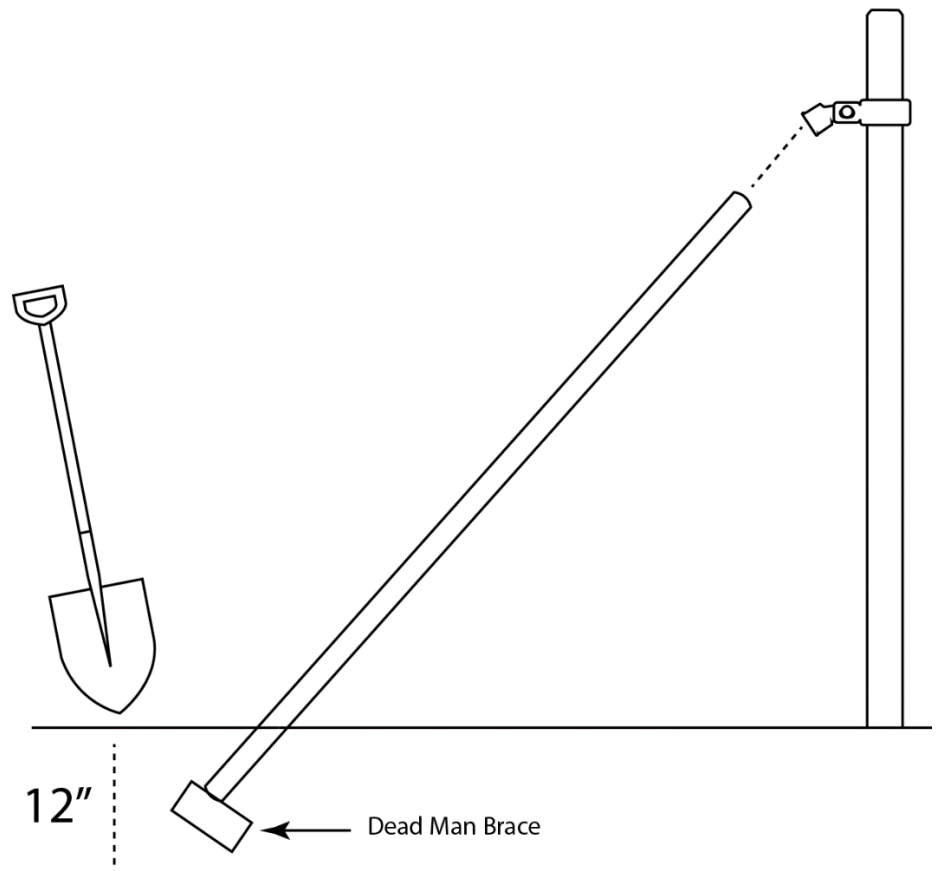

1. Once the dead man is in place, adjust your **BRACE POST (F)** so it rests tightly against the dead man. Fill the hole back up with dirt and tamp down. Secure the **BRACE POST (F)** by drilling a **SELF-TAPPING SCREW (G)** through the **BRACE CUP (A)** and **BRACE POST (F)**. Once secured, tighten the **CARRIAGE BOLT (C)** on the brace band.

5.

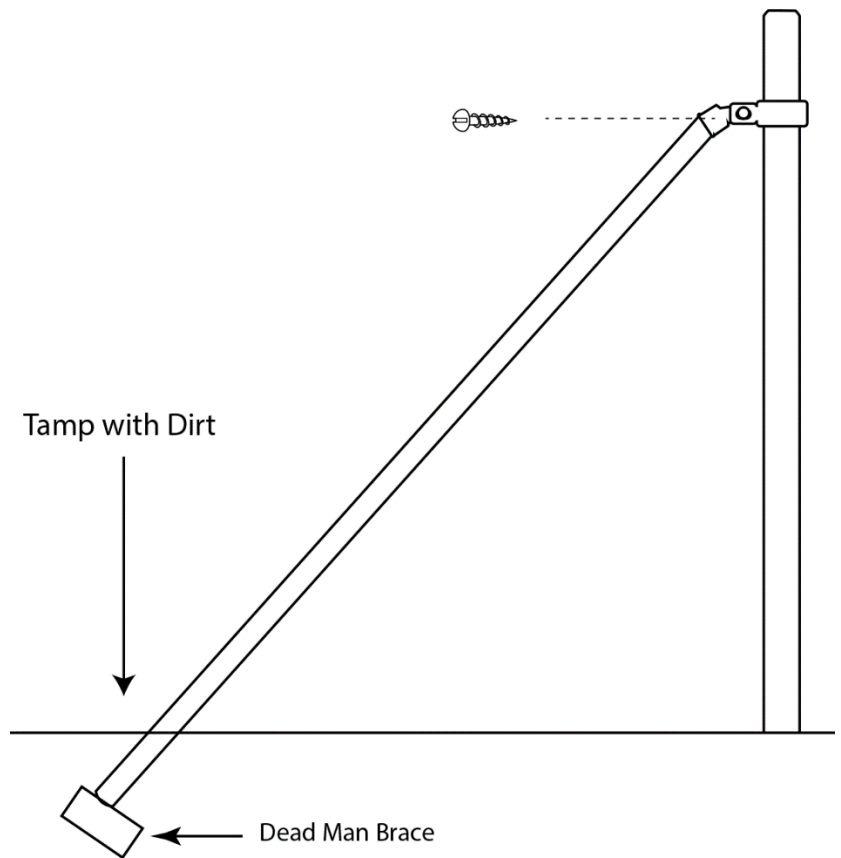

## Birds Eye View

