

REV	ECN NO.	CHANGE CONTENT	SIGNATURE	DATE
A1		First Issued		

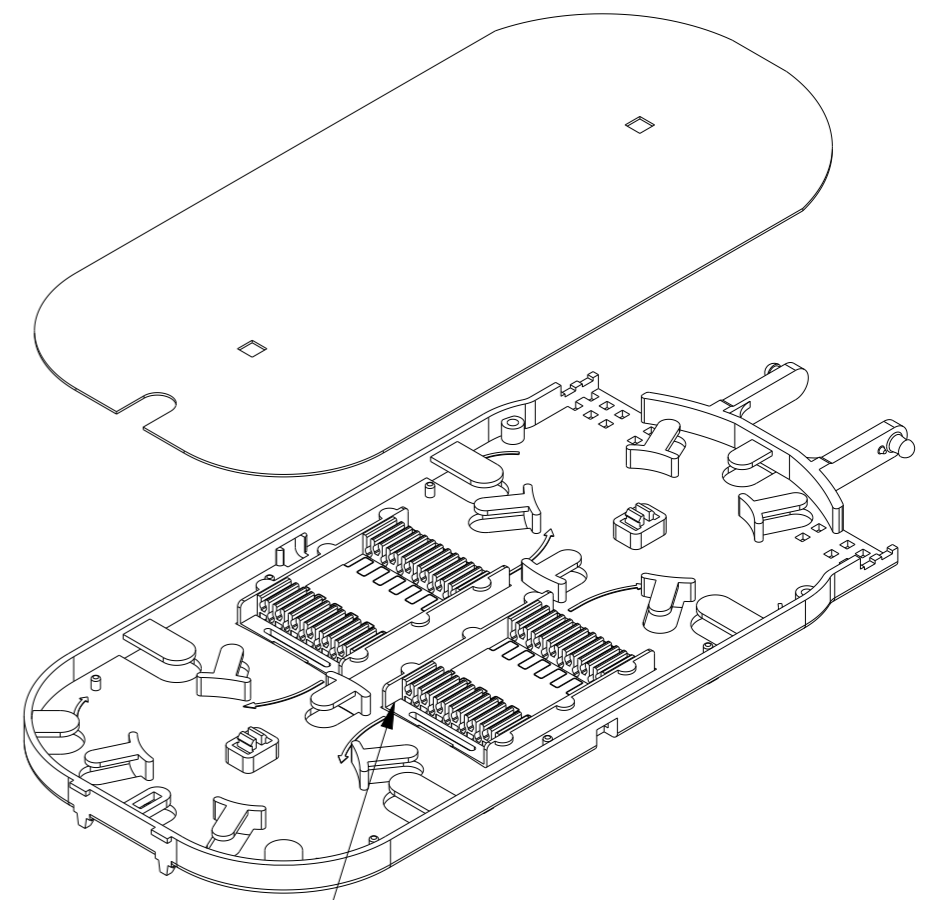

Replaceable splice chips as below

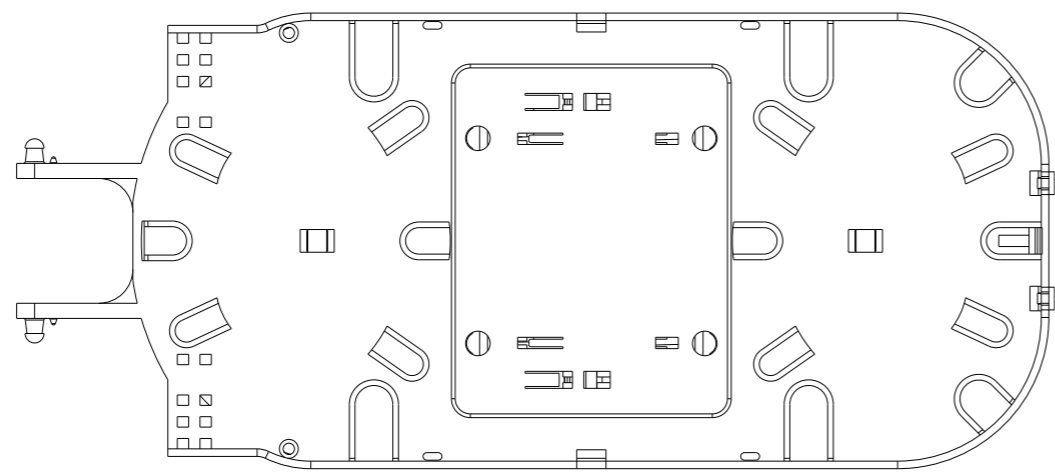
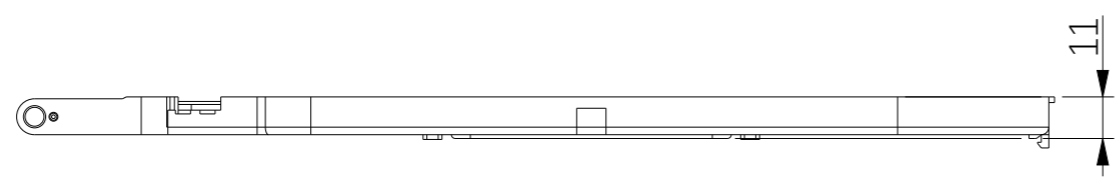
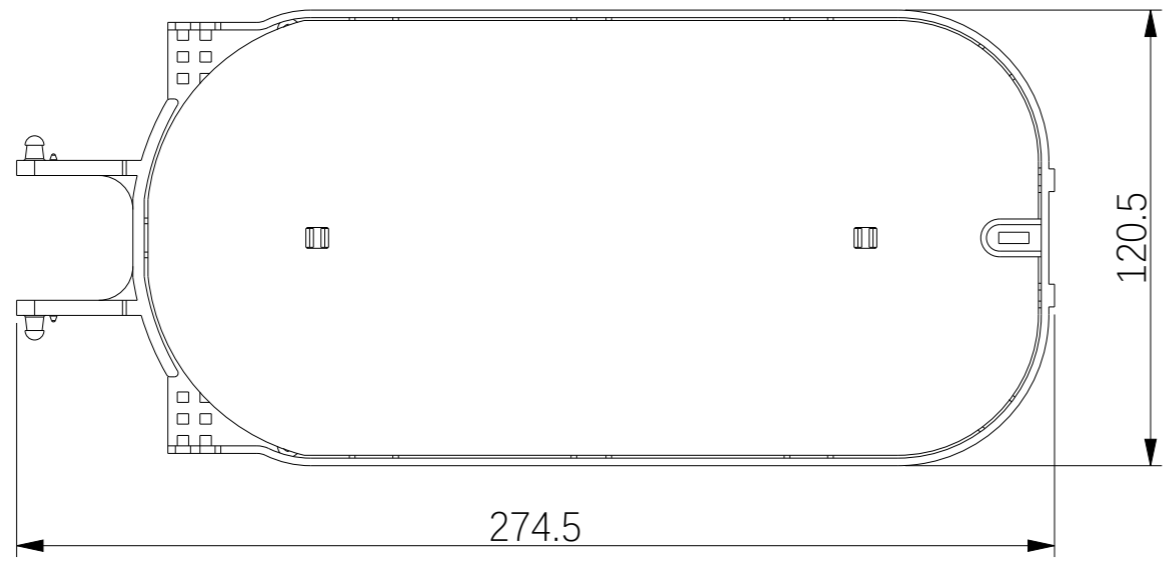
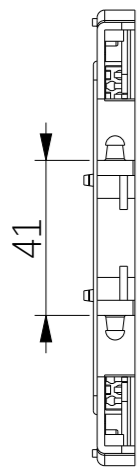
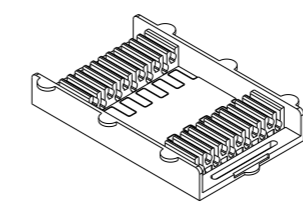

Splice chips

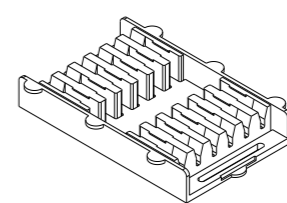

Mass fusion splice chips

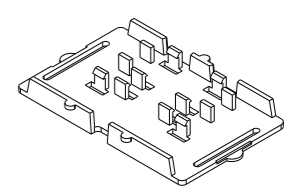

Splitter hold splice chip

NOTE:  
 1. Material: ABS+PC;  
 2. Assembly with Replaceable Splice chips.

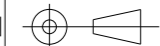
		SIGNATURE	DATE			
DRAWN	FC SONG	2022-09-28	MAT'L	/	PRODUCT NO.	ST-PA-24-HD
CHK'D	TAO LUO	2022-09-28	UNITS	mm	PRODUCT NAME	HyperDropCAN™ 24F splice tray
PROCESS		2022-09-28	SCALE	1:2	DRAWING NO.	
APPV'D	ZIDI YE	2022-09-28	TYPE OF PROJECTION			SHEET 1 OF 1
					REV	A1

REV	ECN NO.	CHANGE CONTENT	SIGNATURE	DATE
A1		First Issued		

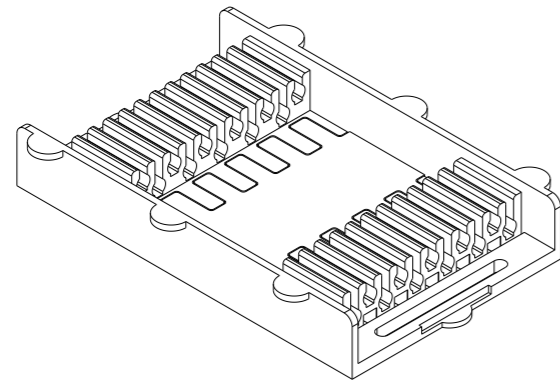

Splice Chips (62.7\*39\*10mm) x 2

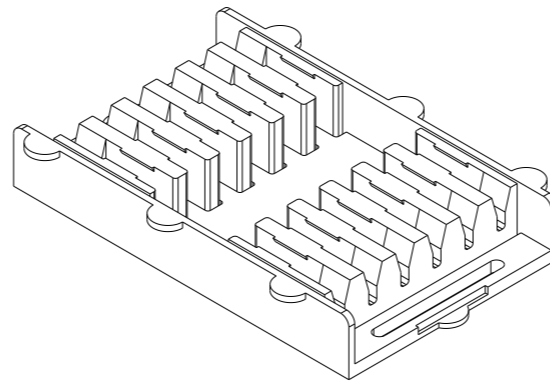

Mass Fusion Splice Chips (62.7\*39\*10mm) x 2

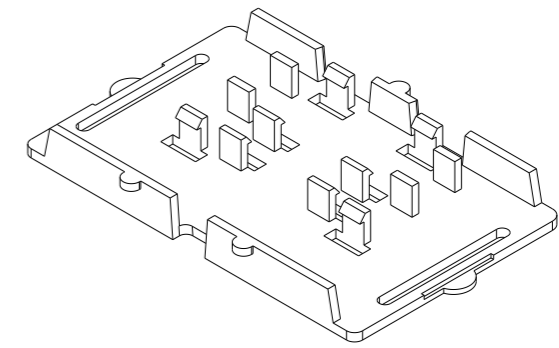

Splitter Hold Splice Chip (62.7\*39\*10mm) x 1

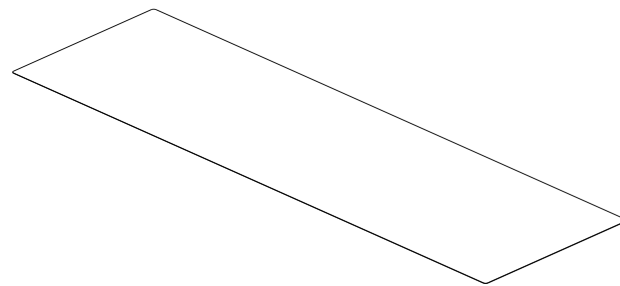

Velcro Cable Tie Chip 25\*300mm

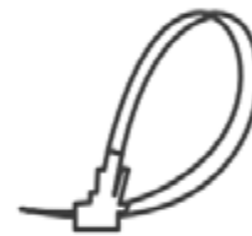

Nylon Cable Tie 2.5\*150mm x 2

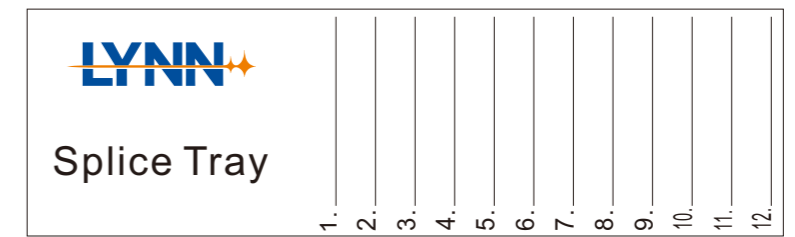

100mm\*30mm Color Printing Label With Logo x 2

/	SIGNATURE	DATE	<b>LYNN</b>				
	DRAWN	FC SONG	2022-09-28	MAT'	/	PRODUCT NO.	Accessories List
	CHK'D	TAO LUO	2022-09-28	UNITS	mm	PRODUCT NAME	
	PROCESS		2022-09-28	SCALE	1:1	DRAWING NO.	
APPV'D	ZIDI YE	2022-09-28	TYPE OF PROJECTION		SHEET 1 OF 1	REV	A1