

Step 1: After the base and worksurface is put together, then place 2 risers on the worksurface with the flat side down.

Step 2: Set the Joey on top of the risers. Then move to the location you prefer.  
Reference dimension for joey to be flush.

Step 3: Install 6 screws. Check to make sure that the screws are the correct length.

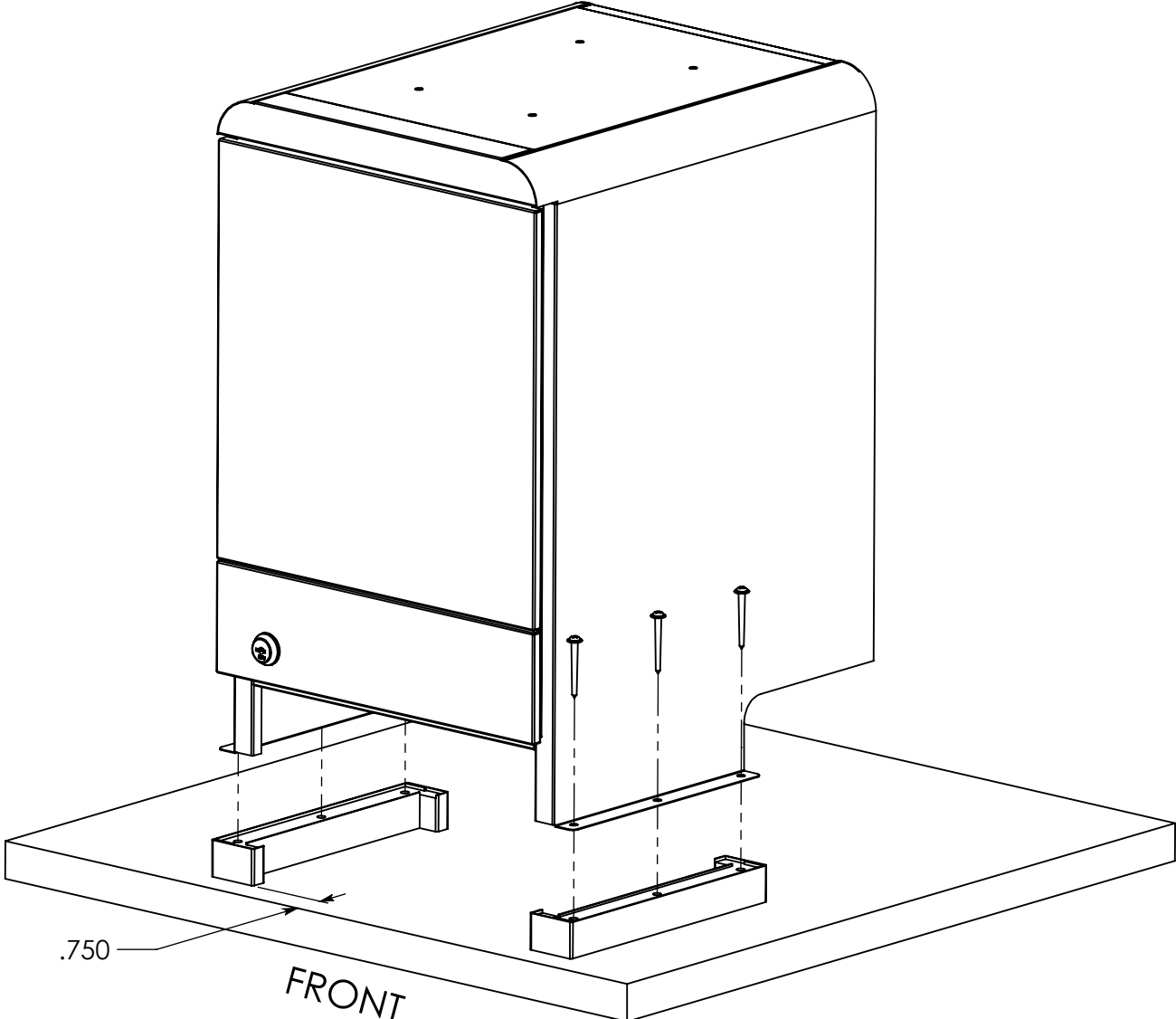

Drawing #802765