



March | 2025 **AUS**

ReidTM SwiftLiftTM JAWSTM Edge Lift Anchors

Compliance Document

ReidTM SwiftLiftTM
JAWSTM Edge Lift
Anchors comply with
AS 3850.1:2024

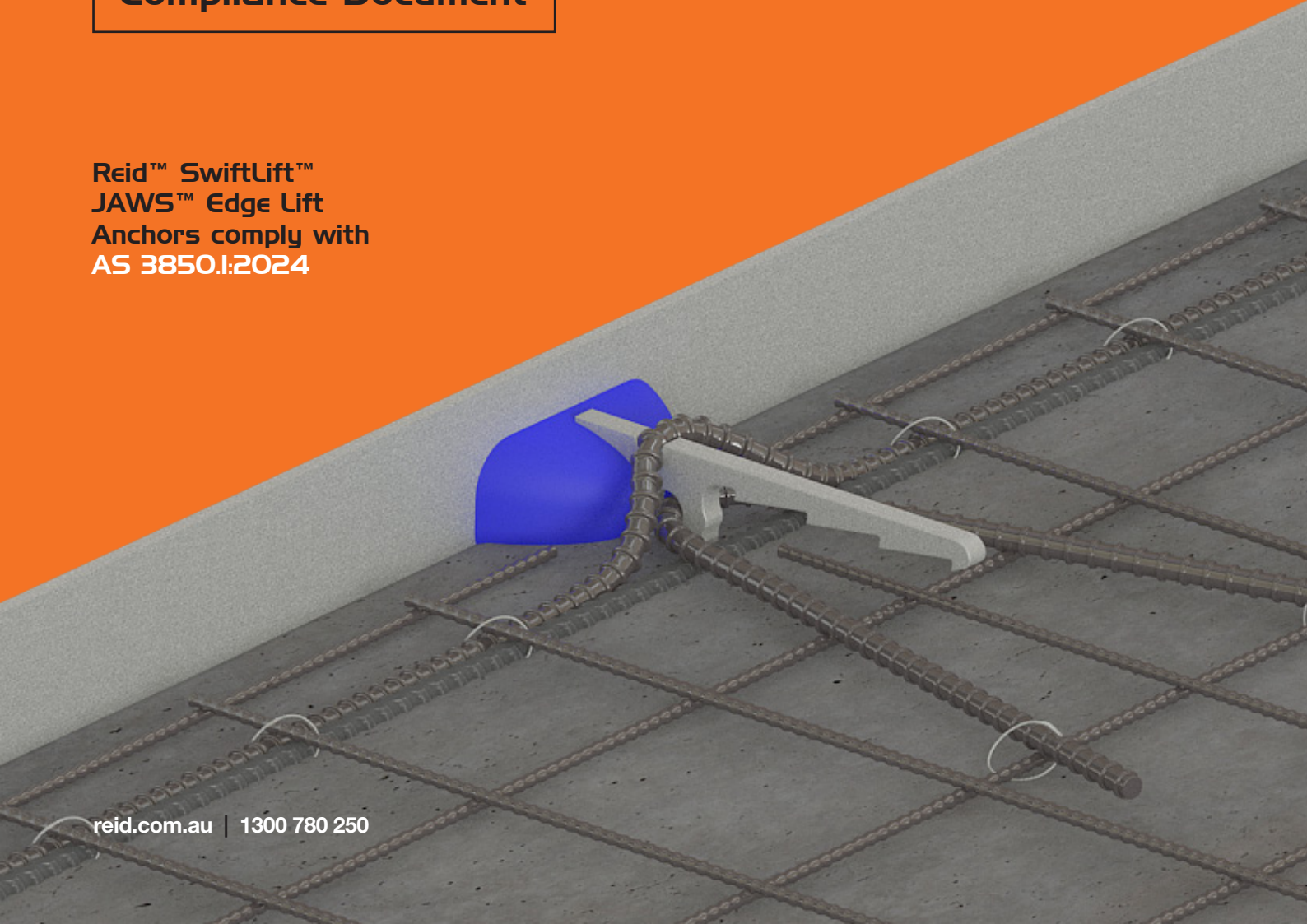

Reid™ SwiftLift™ JAWS™ Edge Lift Anchors



The Reid™ SwiftLift™ JAWS™ Edge Lift Anchors have been designed in Australia to perform under Australian conditions, in Australian concrete, reinforced with Australian reinforcing bar and mesh.

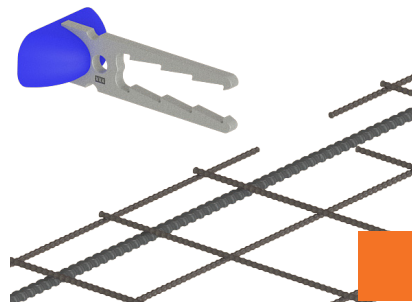

AS 3850.1:2024 Compliant



Figure 1:
Reid™ SwiftLift™ JAWS™ Edge Lift Anchors

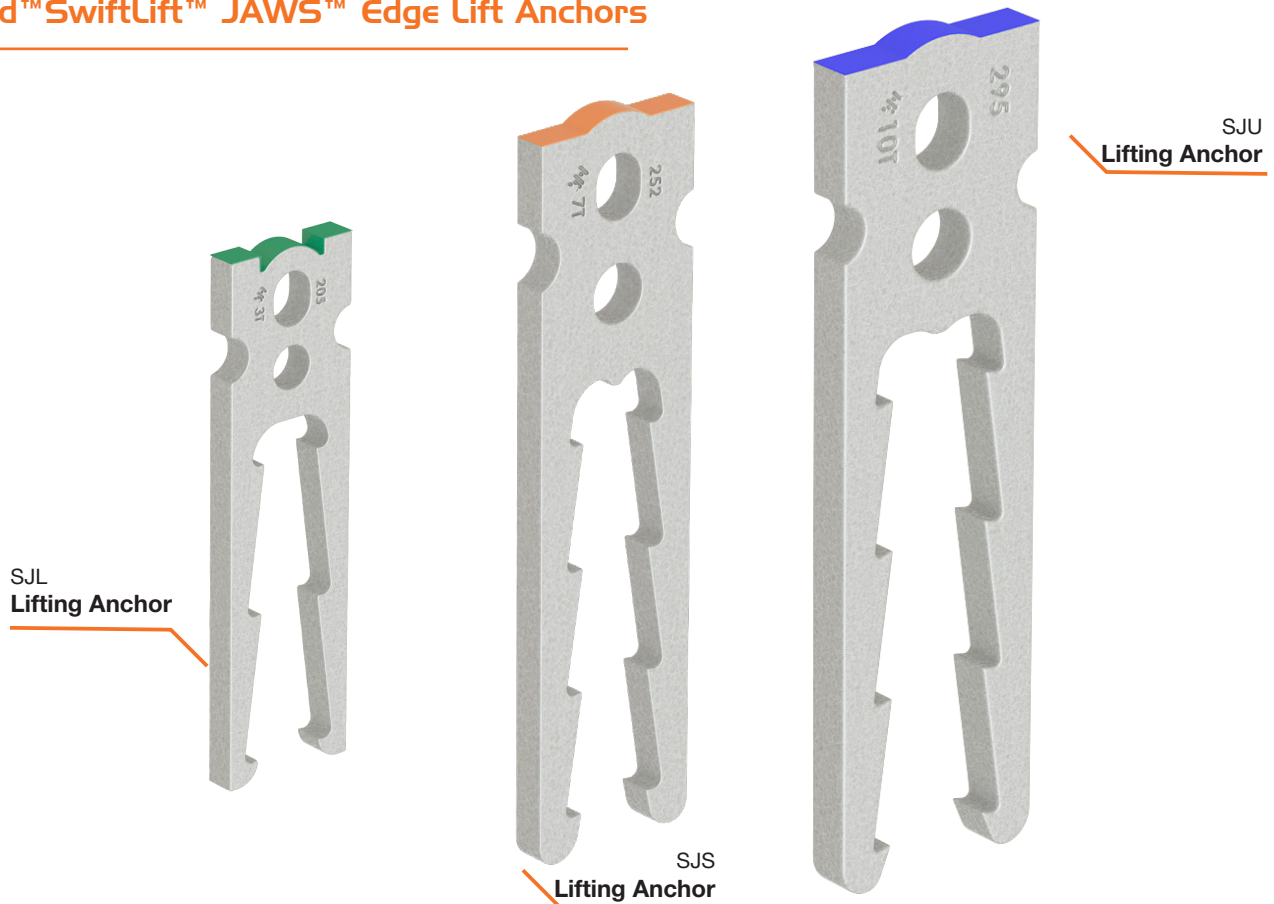

Compliance Details

Table I: AS 3850.1:2024 Compliance Details

Clause	Requirement	Compliant
2.2	The Working Load Limit has been determined by testing in accordance with Appendix A, using a FOS per Table 2.1.	
2.5.1	Manufactured from ductile steel.	
2.5.2.1	WLL determine per clause 2.2	
	Manufactured from ductile steel which exhibits plastic deformation prior to failure at all service temperatures for which the insert is designed to be used.	
	When loaded to tensile failure, a ductile failure and plastic deformation is observed and the failure surface is fully fibrous with no cleavage fracture.	
	Insert assembly including void former shall be marked to ensure compatibility with other system components.	 Refer Figure 2
A2	Concrete for testing complies with AS 1379, tested per AS 1012.	
A3	Testing and recording of results.	
A4	Statistical evaluation of test results, using formula A4, $X_k = x(1 - k_s \text{COV})$.	
A5	Production Validation through testing to confirm compliance of critical specification requirements (dimensions, material properties and load bearing capacity where appropriate).	
A6	Tension testing of the manufactured lifting insert.	
A7	Characteristic capacity determined from a comprehensive test program including individual and combined effects per Table A3.	

Reid™ SwiftLift™ JAWS™ Edge Lift Anchors
comply with **AS 3850.1:2024**



Product Specifications



**Reid™ SwiftLift JAWS
Edge Lift Anchors – made
from Australian DNA.**

Compliant to AS 3850.1:2024, JAWS offers Precasters edge lift solutions with a rated WLL across range 3t – 10t for typical concrete strengths.

The JAWS teeth configuration allows extremely high retention loads in concrete without the lateral bursting forces that are generated by traditional wavy leg or hairpin anchors.

JAWS Anchors allow for earlier lifting due to their ability to preform with lower concrete strengths. With a range of WLL's, JAWS Anchors can be used in panels as thin as 100mm.

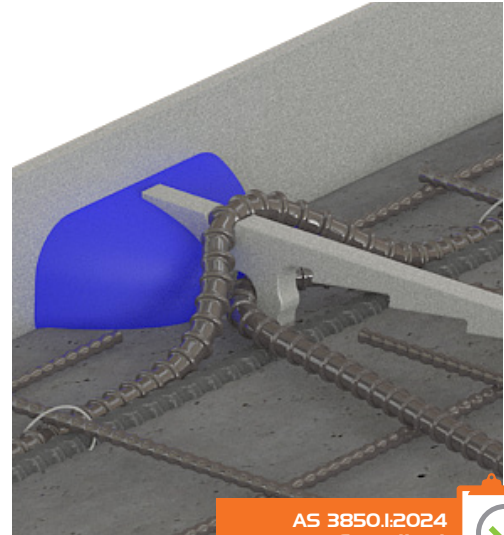

AS 3850.1:2024
Compliant



Figure 2: Reid™ SwiftLift™ JAWS™

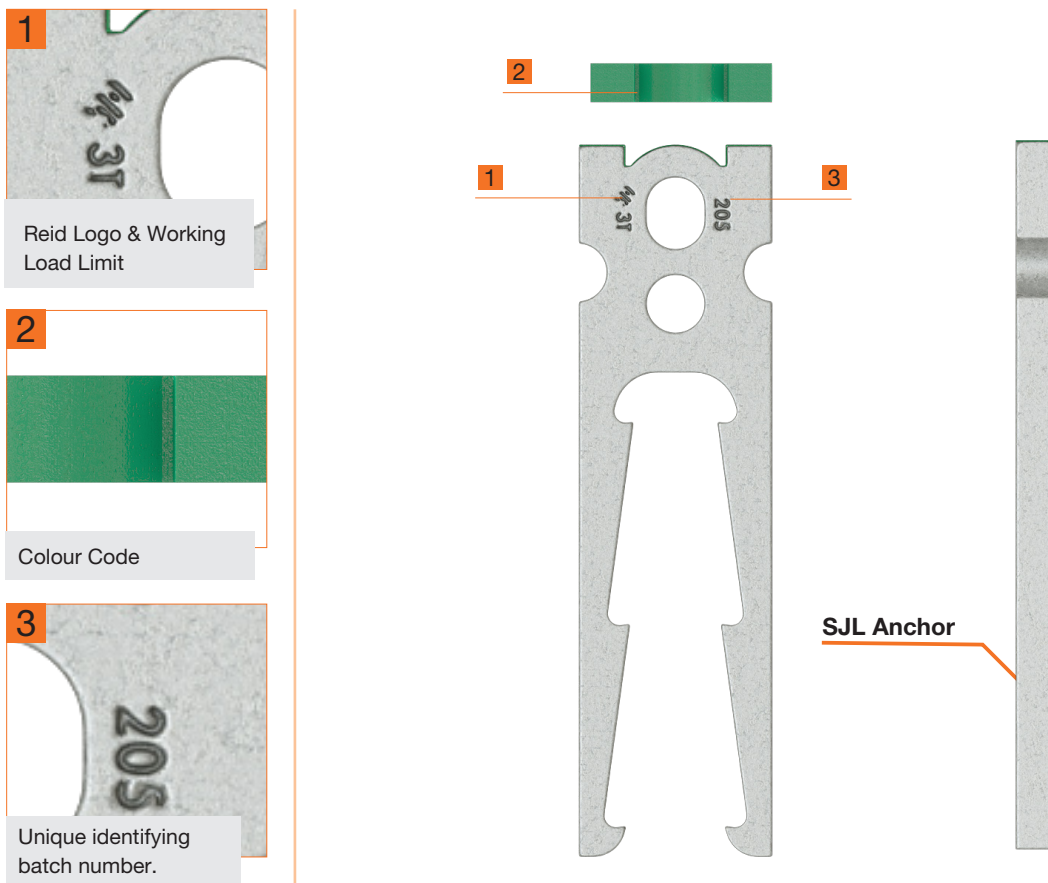







Table 2:
Reid™ SwiftLift™ JAWS™ Edge Lift Anchors System







3 Tonne Reid™ SwiftLift™ JAWS™ Edge Lift Anchors System:

Part	Part No.	AS 3850 Compliant
Anchor	 SJL	
Lifting Clutch	 SJLLC	
Void Former	 SJLVF	

7 Tonne Reid™ SwiftLift™ JAWS™ Edge Lift Anchors System:

Part	Part No.	AS 3850 Compliant
Anchor	 SJS	
Lifting Clutch	 3DX85LC	
Void Former	 3DX85VF	

10 Tonne Reid™ SwiftLift™ JAWS™ Edge Lift Anchors System:

Part	Part No.	AS 3850 Compliant
Anchor	 SJU	
Lifting Clutch	 SJULC	
Void Former	 SJUVF	

Reid™ SwiftLift™ JAWS™ Edge Lift Anchors

Performance Data

Table 3: AS 3850.1:2024 Tensile and Shear Performance Data (WLL), Tonnes

Panel Thickness (mm)	Part No.	Max WLL (tonne)	Stripping		Placement			Tension Bar**
			15MPa	20MPa	25MPa	32MPa	40MPa	Ø and Leg Length (mm) Refer to Figure 6
			Tensile/Shear	Tensile/Shear	Tensile	Tensile	Tensile	
100	SJL	3.0	2.40 / 1.30	2.70 / 1.35	3.00*	3.00*	3.00*	N12 x 300
125	SJL	3.0	2.70 / 1.50	3.00* / 1.50	3.00*	3.00*	3.00*	N12 x 300
	SJS	7.0	7.00*/ 2.00	7.00*/ 2.30	7.00	7.00	7.00	N16 x 500
	SJU	10.0	7.10 / 2.20	7.60 / 2.40	8.00	8.40	8.90	N16 x 500
	SJU	10.0	8.60 / 2.20	9.10 / 2.40	9.40	9.70	9.90	N16 x 750
150	SJL	3.0	3.00* / 1.50	3.00* / 1.50	3.00*	3.00*	3.00*	N12 x 300
	SJS	7.0	7.00*/ 2.30	7.00*/ 2.60	7.00	7.00	7.00	N16 x 500
	SJU	10.0	7.90 / 2.30	8.60 / 2.60	9.10	9.60	10.00*	N16 x 500
	SJU	10.0	9.40 / 2.30	10.00* / 2.60	10.00*	10.00*	10.00*	N16 x 750
	SJU	10.0	10.00* / 2.30	10.00* / 2.60	10.00*	10.00*	10.00*	N20 x 750
175	SJS	7.0	7.00*/ 2.60	7.00*/ 2.80	7.00	7.00	7.00	N16 x 500
	SJU	10.0	8.70 / 2.60	9.50 / 2.80	10.00*	10.00*	10.00*	N16 x 500
	SJU	10.0	10.00* / 2.60	10.00* / 2.80	10.00*	10.00*	10.00*	N16 x 750
	SJU	10.0	10.00* / 2.60	10.00* / 2.80	10.00*	10.00*	10.00*	N20 x 750
200	SJS	7.0	7.00*/ 2.70	7.00*/ 2.90	7.00	7.00	7.00	N16 x 500
	SJU	10.0	9.50 / 2.70	10.00* / 2.90	10.00*	10.00*	10.00*	N16 x 500
	SJU	10.0	10.00* / 2.70	10.00* / 2.90	10.00*	10.00*	10.00*	N16 x 750
	SJU	10.0	10.00* / 2.70	10.00* / 2.90	10.00*	10.00*	10.00*	N20 x 750
300	SJU	10.0	10.00* / 4.10	10.00* / 4.60	10.00*	10.00*	10.00*	N16 x 750
	SJU	10.0	10.00* / 4.10	10.00* / 4.60	10.00*	10.00*	10.00*	N20 x 750

WLL Load capacities include minimum panel reinforcement: SL82, N16 perimeter, centrally placed.

* WLL limited by clutch.

** Tension bar with material properties in accordance with AS/NZS 4671:2019 Grade 500N



Reid™ SwiftLift™ JAWS™ Edge Lift Anchors

Product Specifications (mm)

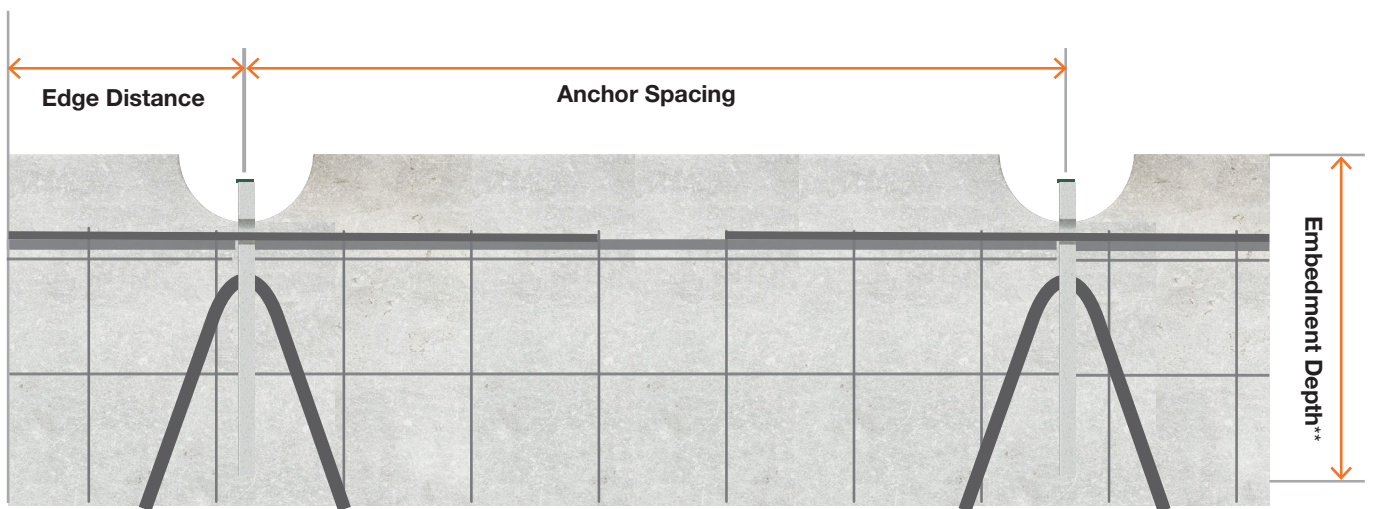

Table 4:
Minimum edge and spacing distances required
to achieve performances in Table 3.

Minimum Edge and Spacing Limits		
Anchor Part Number	Edge Distance (mm)	Anchor Spacing (mm)
SJL	300	700
SJS	420	840
SJU	450	900

**Embedment depth is the effective depth of whole system (Recess former, Edge Lift Anchor and the tension bars).



Figure 3:
SJL
Clutch, Anchor
& Void former

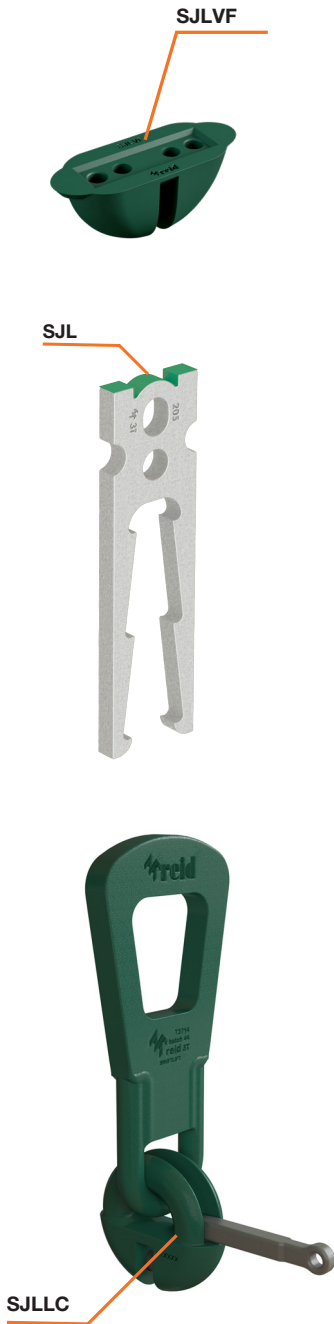

Figure 4:
SJS
Clutch, Anchor
& Void former

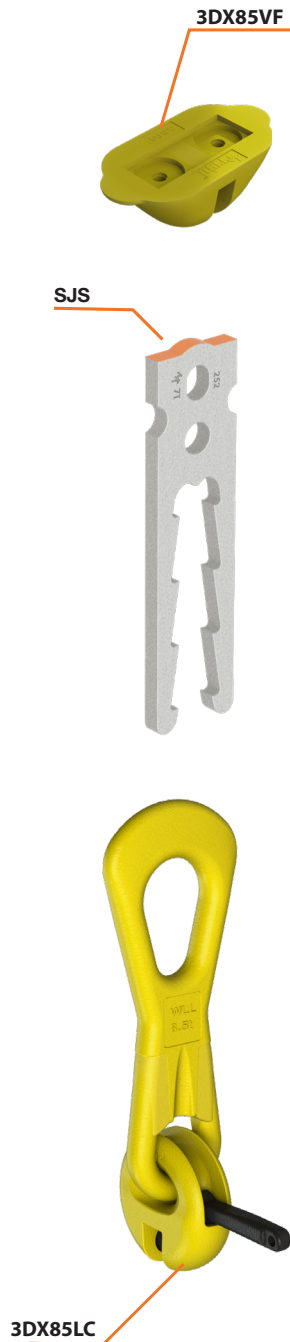

Figure 5:
SJU
Clutch, Anchor
& Void former



Installation support details

Installation Support Details

- Anchors must be orientated at right angles to the edge of the panel, and have the appropriate reinforcing bars fitted through the lower hole in the anchor (tension) & resting in the notch, whilst being tied to the surrounding reinforcement (shear) (See image below). To achieve the desired capacity refer Table 3 for tension bar size.

These bars must be bent down into the panel at an included angle of 30 - 60° and with a bend diameter of 4x the bar diameter.

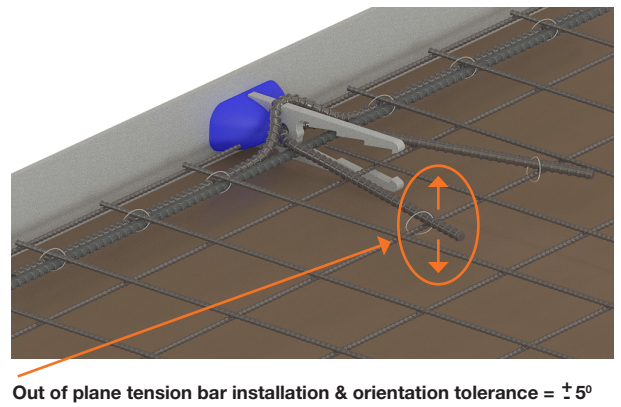
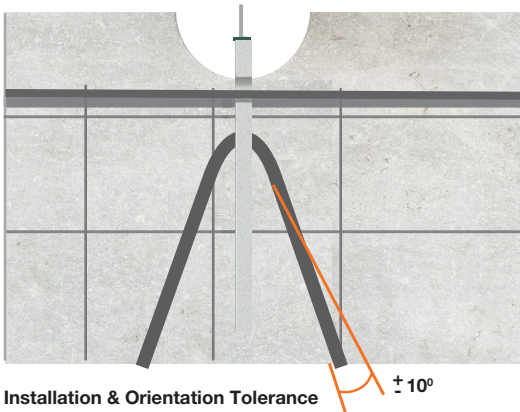
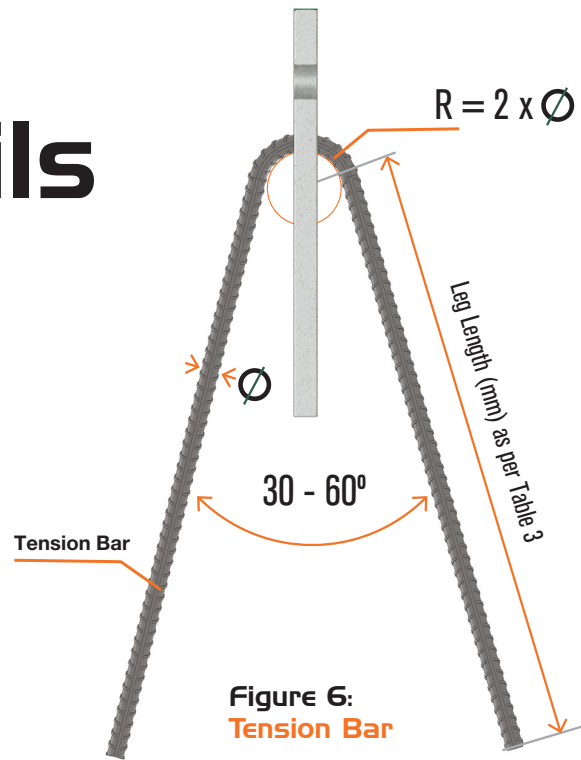
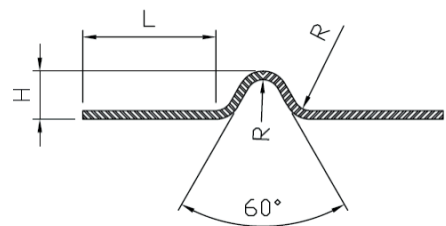

Table 5: Shear bar details

Anchor Part Number	Part Numbers and Dimensions			
	Diameter, mm	Bend Radius, (R) mm	Length, (L) mm	Height, (H) mm
SJU	N16	32	300	90
SJS	N12	24	250	90
SJL	N10	20	200	60



Quality and Compliance

AS 3850.1:2024
Compliant



All Reid™ branded products and all products manufactured at our Melbourne manufacturing facility are designed, manufactured, tested and supplied in compliance with our Quality Management System which has been independently audited and certified by SAI Global to ISO 9001:2015. Reid™ undertake strict quality control processes to ensure performance specifications and metallurgical properties are maintained.

To reflect the continued progress of the industry and the new innovative uses of precast and tilt-up construction, Australian Standard AS 3850 Part 1 and Part 2 has recently been updated in 2024. AS 3850 Part 1, Part 2 and Part 3 are detailed below.

- Part 1, called 'General requirements' details the updated performance and testing requirements for suppliers of componentry into the industry. These requirements are significantly different to AS 3850:2015 and should enable the industry to have greater confidence in the products that they are specifying and using.
- Part 2, called 'Building construction', aligns with the 2008 National Code of Practice for Precast, Tilt-Up and Concrete Elements in Building Construction and focuses on the interrelation of the various stages of manufacture, construction, transport and erection. It is specifically for the construction design and documentation of prefabricated concrete elements in building construction and provides guidance for the Erection Designer and highlights the importance of the Erection Design and Documentation. It was updated to align with the changes in Part 1 and the content in Part 3.
- Part 3, called 'Civil construction' provides requirements impacting prefabricated concrete elements in civil, infrastructure and non-building construction. Similar to Part 2, it focuses on various stages of safety, planning, manufacturing, construction design, casting, transportation, erection and incorporation into the final structure.

The new AS 3850.1:2024 is central for the safe, efficient and cost-effective manufacture, construction, transport and erection of prefabricated concrete elements.



Quality and compliance are at the core of everything we do. Our commitment to ISO 9001:2015 certification ensures every Reid™ product meets the highest standards of safety, performance, and reliability.

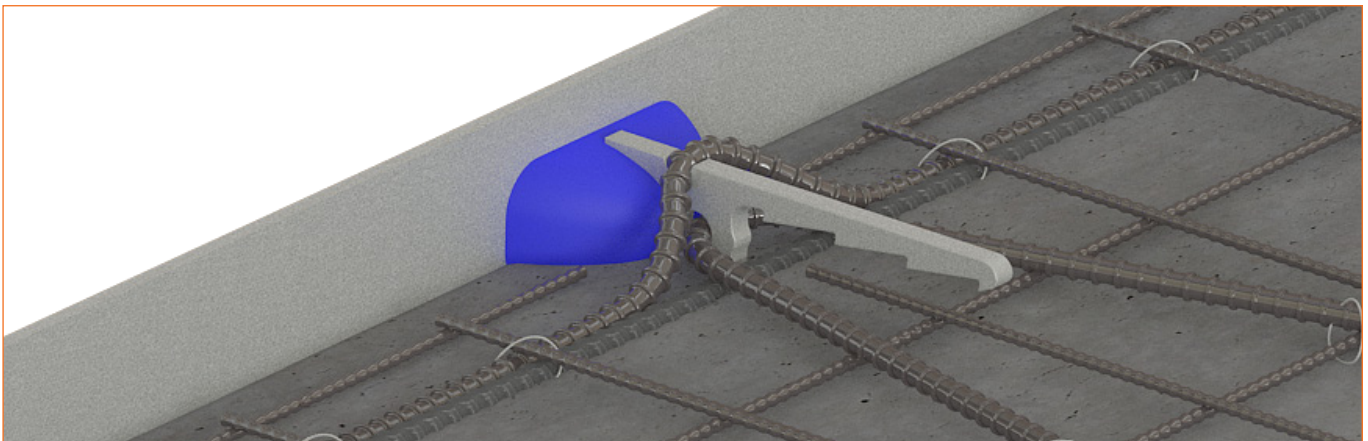

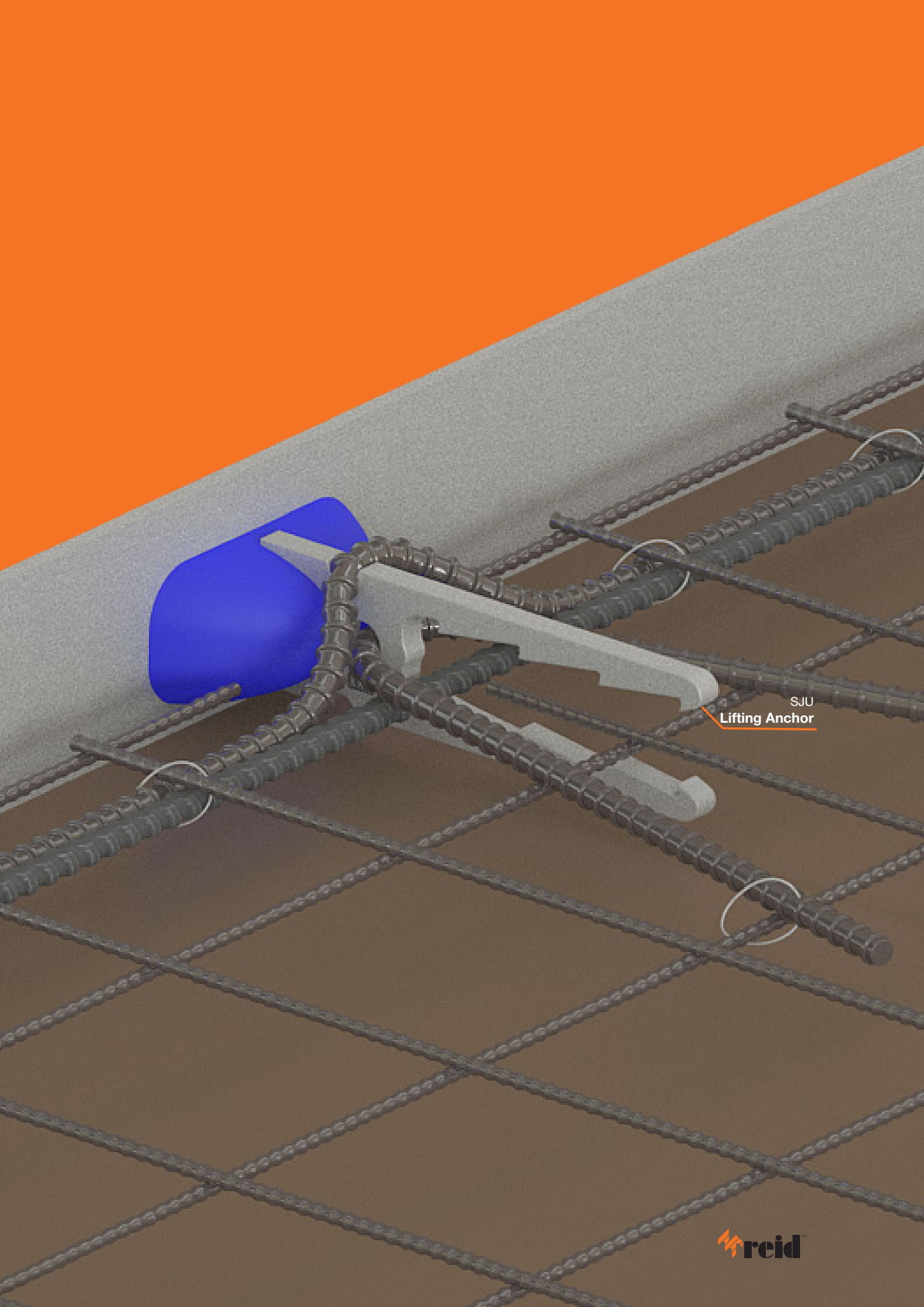

SJU
Lifting Anchor



Customer Service

Reid™ Australia

Tel: 1300 780 250

Email: sales@itwcsanz.com

Web: www.reid.com.au

Reid™ New Zealand

Tel: 0800 88 22 12

Email: sales@ramsetreid.co.nz

Web: www.reids.co.nz

Reid™

AUS: 1 Ramset Drive, Chirside Park, Victoria, Australia, 3116

NZ: 23-29 Poland Road, Glenfield, Auckland 0632

Information in this document is correct at the time of printing. Readers should contact Reid or consult Reid detailed technical information to ensure product is suitable for intended use prior to purchase. ITW Australia Pty Ltd ABN 63 004 235 063 trading as Reid © copyright 2025™ Trademarks of Cetram Pty. Ltd. Used under license by Reid

Important Disclaimer: Any engineering information or advice ("Information") provided by Reid in this document is issued in accordance with a prescribed standard, published performance data or design software. It is the responsibility of the user to obtain its own independent engineering (or other) advice to assess the suitability of the Information for its own requirements. To the extent permitted by law, Reid will not be liable to the recipient or any third party for any direct or indirect loss or liability arising out of, or in connection with, the Information. None of the products listed in this document are subject to a warning or ban under the Building Act 2004.