

RapidBraceTM

Cast-in Brace Anchor System

Installation Guide

The following document contains important user information with regards to the installation of the RapidBrace Assembly.



RapidBrace Installation Guide

RapidBrace cast-in Brace Anchor System enables structural bracing in early strength concrete.

RapidBrace is cast-into the concrete floor and is ready to load in concrete with compressive strength as low as 8 MPa, depending on engineering requirements.

RapidBrace Brace Anchor System Key Features:

- Ductile Brace Anchor System
(see Reference no. 5 found at the end of this document, Worksafe Victoria Alert on Precautions in using high tensile formwork bar. ReidBar is not a high tensile formwork tie or 'Z-tie')
- High strength brace anchoring in low strength concrete
- Improved floor cycle times from earlier panel / steel erection
- Achieves nominal 500N grade ReidBar steel strength in low strength concrete
- Full conformance to AS 3850.1:2015 (+A1:2019)
- Tested to AS 3850.1:2015 (+A1:2019) Appendix A in concrete < 12MPa
- Compliance testing for installation in composite slab (steel tray decking)
- Guidance for Post tensioned slab installations

Figure 1: RapidBrace set into concrete floor slab

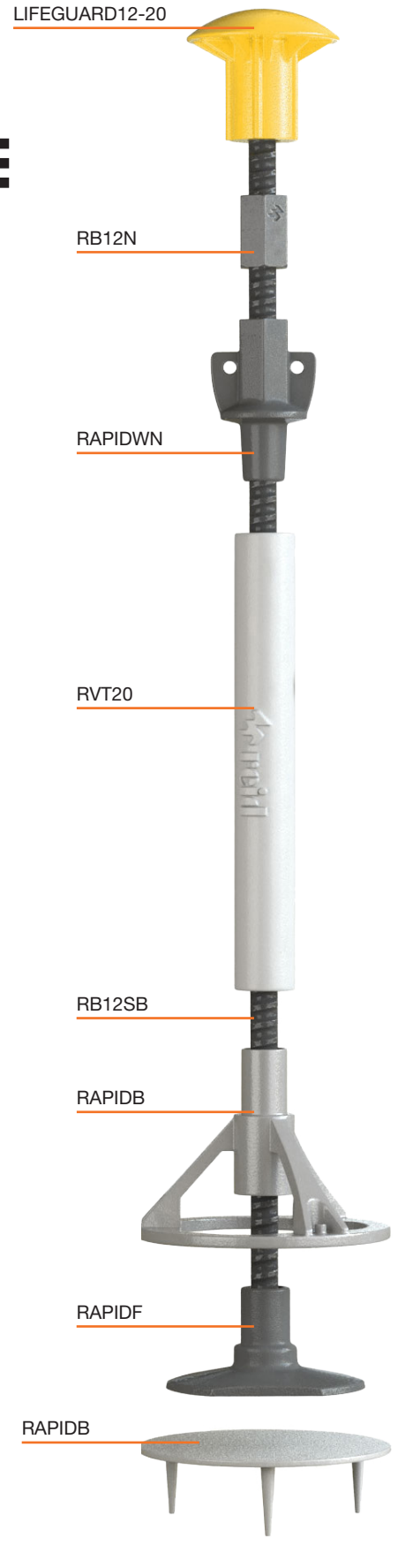

Table I - RapidBrace System Components

Part Number	Description	Pack Quantity
Consumable		
RVT20	Reid Void Tube 3 m length	10no. x 3m/bundle
RAPIDF	RapidBrace Foot	25 no.
RAPIDB*	RapidBrace Tripod & Spacer Disk Base	25 no.
Re-Usable Items		
RB12N	ReidBar 12 mm Nut	50 no.
RAPIDWN	RapidBrace Wing Nut	50 no.
RB12SB	ReidBar 12 mm Starter Bar 540mm long	-
LIFEGUARD12-20	Danley™ Life Guard Protective Cap	50 no.

INSTALLATION: Before concrete placement

Step 1

DETERMINE IF ADDITIONAL COVER IS NEEDED

Before Concrete Placement, determine if concrete cover is required under the brace foot. Refer to Fig 1 & 2 below. **Order RapidBrace system items outlined in table above.**

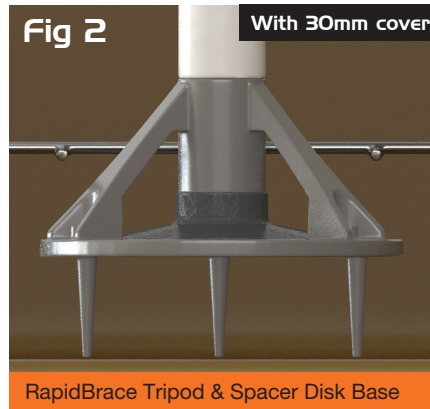
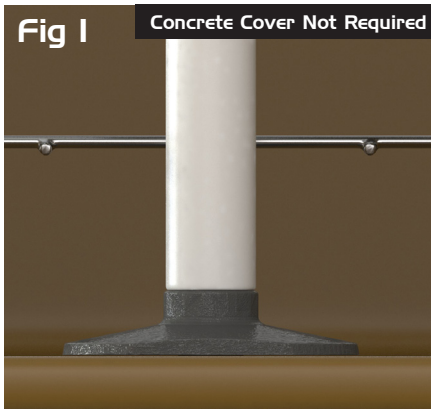

Figure 1 –

RapidBrace Foot directly fixed to slab formwork – no cover required

Figure 2 –

RapidBrace Assembly using RAPIDB component where cover to concrete is required

Step 2a

Cut Reid Void Tube (RVT20) to length as follows:

Tube Length = Depth of Concrete Slab (D) + 75 mm

For Example: For 200 mm thick slab, cut RVT20 to 275 mm lengths.

This is to allow at least 75 mm of tube projecting above the concrete surface for clearance to screed and trowel.



Reid Void Tube

Ensure that the RVT20 is long enough, so that it is visible and extends above the concrete floor level by 75 mm.



Assembly and Installation in slab with no concrete cover

1. Rotate ReidBar starter bar (RB12SB) into RapidBrace Foot (RAPIDF) until the ReidBar thread is fully engaged. Thread length of RAPIDF is 42 mm.
2. Slide the cut to length Reid Void Tube (RVT20) over free end of starter bar (RB12SB) until it fits snugly over the top end of the RapidBrace Foot (RAPIDF)
3. Screw on wing nut (RAPIDWN) onto the starter bar (RB12SB) until it reaches the top of the Void Tube (RVT20). Tighten finger tight.
4. Screw on lock nut (RB12N) onto starter bar (RB12SB) until it reaches the top of the wing nut (RAPIDWN). Tighten finger tight.
5. Cover the wing nut (RAPIDWN) and lock nut (RB12N) with duct tape. The tape should extend from the top of the void tube, over the wing nut and lock nut and 25 mm of starter bar above the lock nut. This will ensure that the threads remain undamaged during the concrete slab pour.
6. Also apply duct tape around the joint between the RapidBrace Foot (RAPIDF) and the bottom of the void tube (RVT20).
7. Fit Life Guard cap (LIFEGUARD12-20) firmly onto free end of starter bar (RB12SB)
8. Using 10 gauge x 15 mm self-tapping screws, secure the RapidBrace Foot to the Soffit formwork (Timber screws for formply and Tech screws for steel profile decking formwork)
9. When fixing to steel profile decking such as Bondek™ or similar products, position the RapidBrace along the centreline of the 'trough' profile. See below fig 3 & 4:



Figure 3 –
Testing installation of Rapidbrace system onto steel profiled decking.

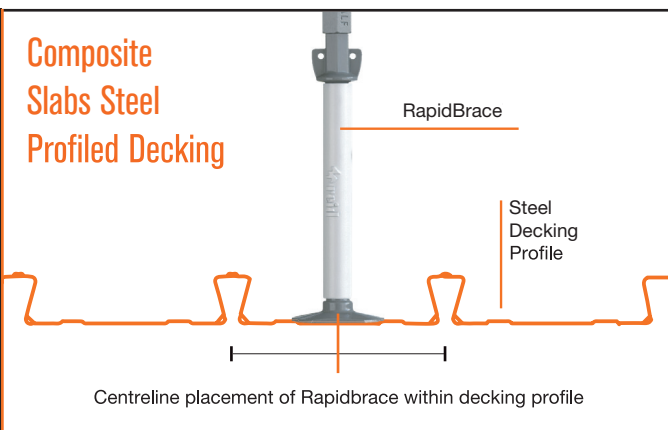

Figure 4 –
Centrally position Rapidbrace within trough of profile.

Step 2b

***Assembly and Installation with 30mm Concrete Cover:**

1. Rotate ReidBar starter bar (RB12SB) into RapidBrace Foot (RAPIDF) until the ReidBar thread is fully engaged. Thread length of RAPIDF is 42 mm.
2. RapidBrace Tripod and Spacing Disc Base are supplied as a set (plastic components). Slide the wide end of RapidBrace Tripod (RAPIDB) over the free end of starter bar (RB12SB) until it fits snugly over the top of the RapidBrace Foot (RAPIDF).
3. Fit the RapidBrace Base (RAPIDB) spacer disc onto the bottom of the Tripod ensuring the legs on the Disc are facing down. The Disc will snap fit into the Tripod ring creating a support chair with 30mm cover.
4. Slide cut to length Reid Void Tube (RVT20) over free end of starter bar (RB12SB).
5. Screw on wing nut (RAPIDWN) onto the starter bar (RB12SB) until it reaches the top of the Void Tube (RVT20). Tighten finger tight.
6. Screw on lock nut (RB12N) onto starter bar (RB12SB) until it reaches the top of the wing nut (RAPIDWN). Tighten finger tight.
7. Cover the wing nut (RAPIDWN) and lock nut (RB12N) with duct tape. The tape should extend from the top of the void tube, over the wing nut and lock nut and 25 mm of starter bar above the lock nut.
8. Also apply duct tape around the joint between the RapidBrace Base (RAPIDB) and the bottom of the void tube (RVT20).
9. Fit Life Guard cap (LIFEGUARD12-20) firmly onto free end of starter bar (RB12SB)
10. Stand the RapidBrace Assembly on the soffit formwork so it is supported by the 3 legs, which will allow 30 mm of concrete cover under the RapidBrace foot. Tie into surrounding reinforcing to prevent RapidBrace falling over during the concrete pour.
11. The assembly is now ready for concrete to be poured.



***If 5mm cover is preferable for exposed off-form soffit, insert Disc with legs facing up as shown in figure.**

Edge, Spacing and other clearances

Edge and spacing distances outlined in the RapidBrace Cast in Brace Anchor System AS 3850.1:2015 (+A1:2019) Compliance documentation must be followed to ensure performance of the system is not compromised.

As a rule of thumb for a 150mm slab:

- Slab edge distance – min 360mm
- RapidBrace Spacing distance – min 720mm
- Post-tensioning Duct clear distance to RapidBrace anchor – min 100mm*

***Testing of the RapidBrace System included locating adjacent to post-tensioning ducts. See Fig 5 and 6 below:**



Figure 5 –
RapidBrace PT
Duct testing setup

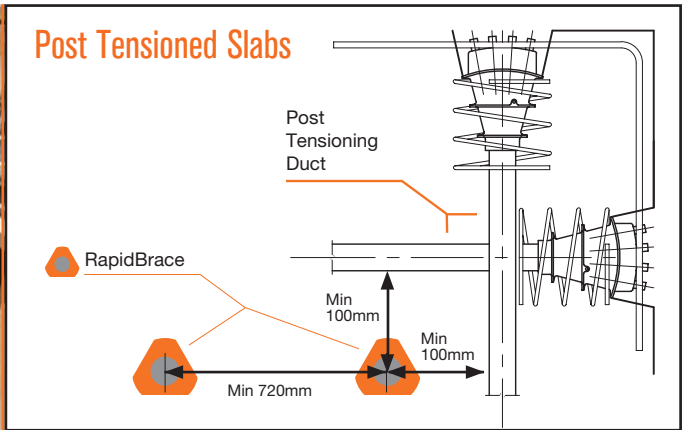

Figure 6 –
Clearances for PT Slab (similar edge and spacing distances apply to conventional RC slabs and composite slabs).

Concrete Finishing

During the concrete pour, ensure that the concreters carefully trowel around the projecting RapidBrace assembly, ensuring that cusping or raised surfaces and/or buildup of concrete slurry are ‘flattened out’ prior to the concrete setting.

INSTALLATION: After concrete placement – Precast Element Erection

RapidBrace may be used for bracing when the concrete has reached the required compressive strength as nominated by the Erection Design Engineer. Further information regarding load design may be obtained from the RapidBrace AS 3850.1:2015 (+A1:2019) Compliance Document available from ramsetreid.

Step 3

Ready RapidBrace for Bracing

1. Remove duct tape from wing nut and lock nut and wind both part way up the starter bar so they are clear of the top of the void tube. Unscrew Reidbar™ RB12SB and remove from void.
2. Cut the void tube with a grinder and or wood saw so it is flush with the concrete surface. The concrete surface must be flat around the void tube with no lip or other deformation that will prevent the brace foot having full contact with the concrete surface. Any lip or deformations must be removed with a surface grinder diamond disc before the bracing installation commences.
3. Ensure void and castin RapidBrace Foot are clear of debris before re-inserting ReidBar assembly into void.
4. Re-insert ReidBar RB12SB, RB12N and RAPIDWN assembly. Turn bar into RapidBrace Foot and ensure bar threads have engaged the castin fitting. The bar must be installed 38-42mm into the fitting below and snug tightened with a 300-450mm long shifter. Replace Life Guard protective cap on top of bar if it was removed.

Step 4

Secure Brace Foot With RapidBrace

1. Ensure Life Guard protective cap is fitted to top of the ReidBar (RB12SB)
2. Position Brace Foot by placing on concrete surface and sliding slotted hole around RapidBrace starter bar
3. Screw down wing nut (RAPIDWN) along starter bar until the flanges are fully bearing against the brace foot.
4. Tighten the wing nut to finger tight by hand then rotate the wing nut by 90° using a shifter minimum 350-400mm long. (Extensive testing by ramsetreid confirms a 90° turn from finger tight will apply a torque of 120 Nm. If using a torque wrench, do not apply more than 120 Nm)
5. Wind lock nut (RB12N) down starter bar until it reaches the top of the wing nut (RAPIDWN)
6. Tighten by hand until finger tight then using 350-400mm long shifter and rotate 45° to ensure published performance is maintained under cyclic loading, vibration and impact.
7. RapidBrace is now ready to accept full load.

Ensure RapidBrace Starter Bar thread is fully engaged with RapidBrace Foot – QA Check

1. Remove Life Guard cap temporarily to allow the starter bar length above the concrete surface to be measured
2. Measure the length of RB12SB (typically 540mm long) from the concrete surface to the top of the bar
3. Depending on amount of concrete cover, the length of bar (l) that confirms adequate thread engagement is (Tolerance +3 mm / -5 mm)
 - A:** No Cover: Length of bar (l) mm = Total Length of RB12SB (L) – Depth of Slab (D) + 4
 - B:** 30 mm Cover: $l = L - D + 37$ mm
 - C:** 5 mm cover (RAPIDB Disc Legs Up) $l = L - D + 7$ (mm)
4. Typical Example with No Cover: $l = 540$ mm – 200 mm + 4 = 344 mm; If bar is longer, thread is not properly engaged. Rotate bar in clockwise direction to ensure maximum thread engagement and re-measure. If full thread engagement is still not confirmed, contact ramsetreid for further advice.
5. Replace Life Guard protective cap

RapidBrace System Installation - 30mm cover shown

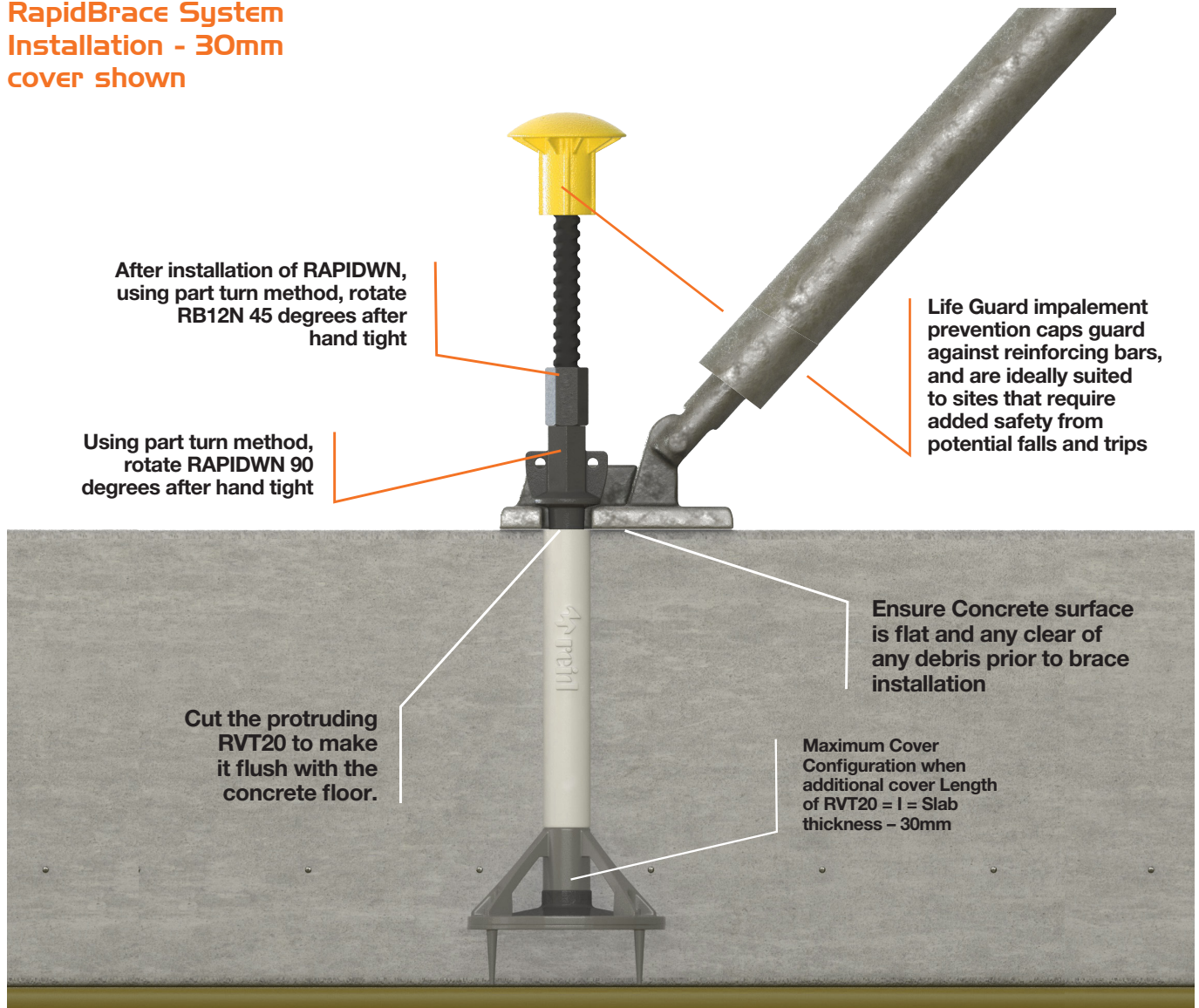

ReidBar Nut & Rapid Wing Nut assembly for secure installation.

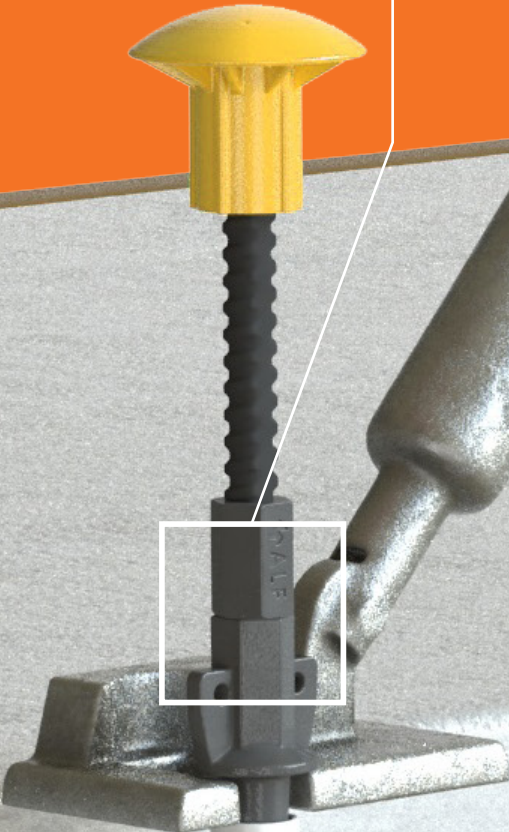

Versatile Reid Void Tube that could be cut to length depending on slab depth.



Multiple base arangement depending on the required concrete cover

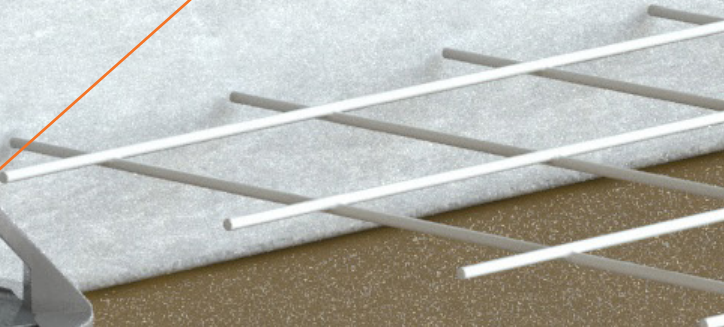

customer service

Reid™ Australia

Customer Service Centre

Tel: 1300 780 250

Email: sales@reid.com.au

Web: reid.com.au

Reid™ New Zealand

Customer Service Centre

Tel: 0800 88 22 12

Email: sales@ramsetreid.co.nz

Web: www.reids.co.nz

ramsetreid™ 1 Ramset Drive, Chirnside Park 3116

Information in this document is correct at the time of printing. Readers should contact ramsetreid™ or consult ramsetreid™ detailed technical information to ensure product is suitable for intended use prior to purchase. ITW Australia Pty Ltd ABN 63 004 235 063 trading as ramsetreid™

© copyright 2020. ™ Trademarks of Cetram Pty. Ltd. Used under license by ramsetreid™

Imagery showing graphic concrete is used with permission of Graphic Concrete Ltd.

