

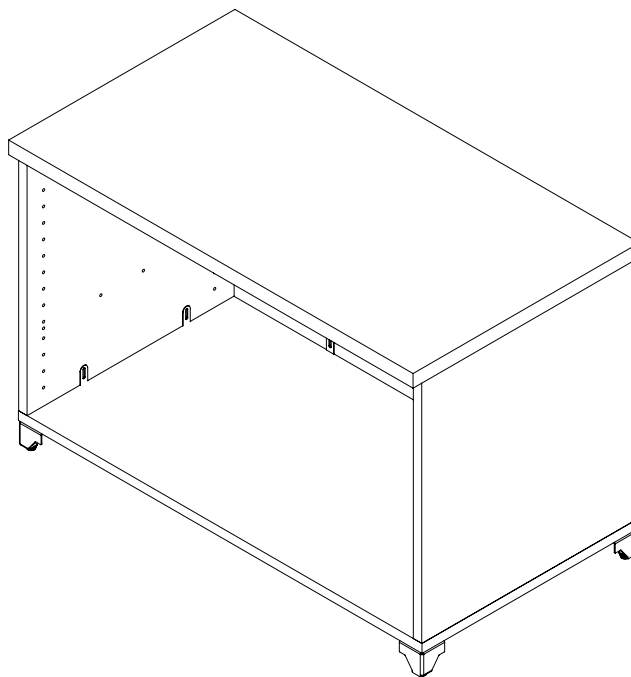

Tevita Casegoods
Single Credenza Assembly Instructions



Warranty: raproducts.com/resources/warranty

Tools Required for Assembly

- A. Power Driver with Adjustable Torque
- B. #2 Square Head Driver Bit

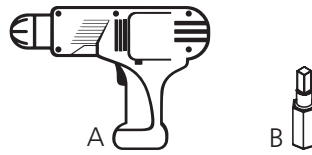

Hardware and Tools Included for Assembly (may have extra)

- C. 4mm Ball End Screwdriver
- D. 5/8" Washer Head Wood Screw x16

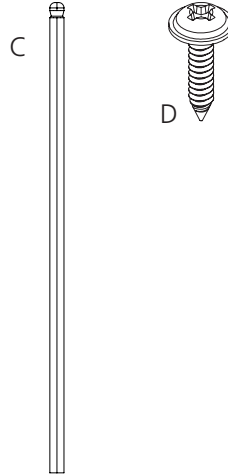

Parts

- E. Feet x4
- F. Bottom Panel x1
- G. Top Panel x1
- H. Left Panel x1
- I. Right Panel x1
- J. Back Panel x1

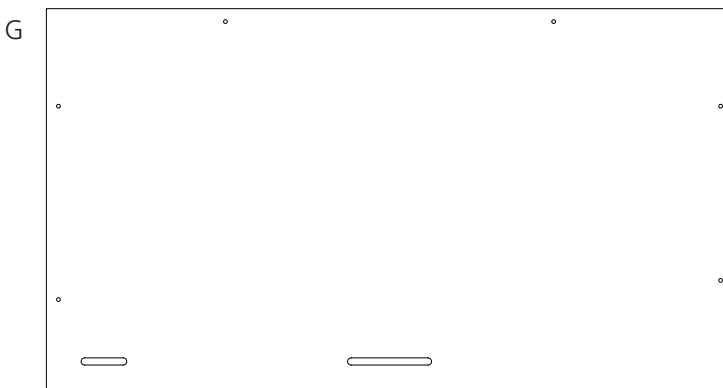
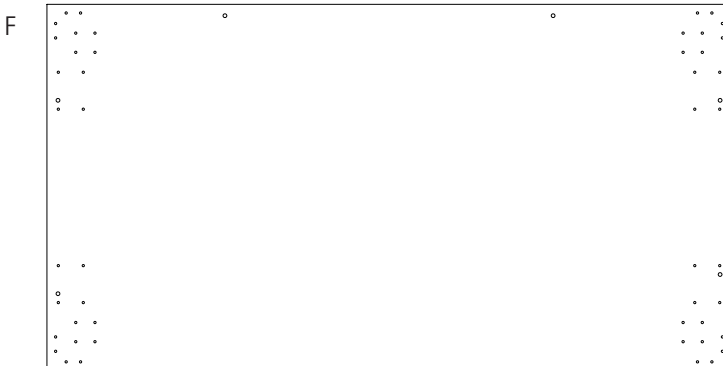
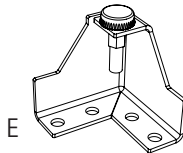

Parts (continued)

H. Left Panel *x1*

I. Right Panel *x1*

J. Back Panel *x1*

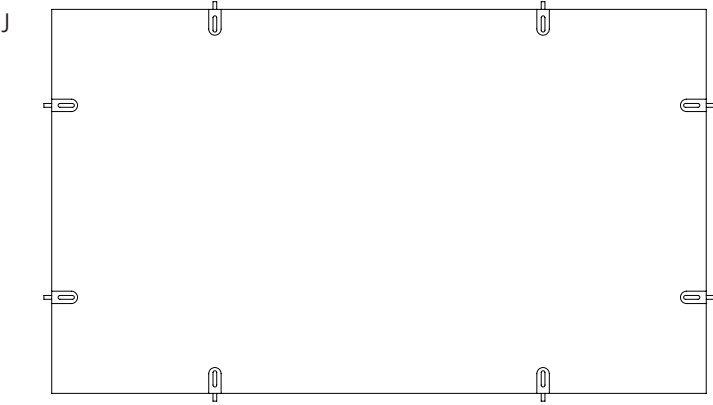
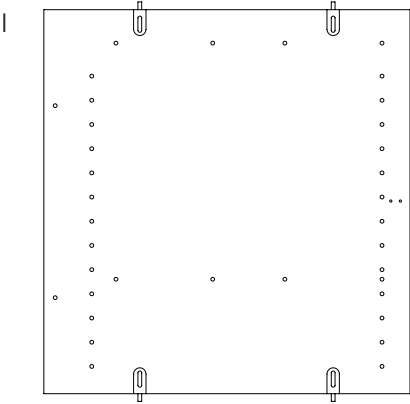
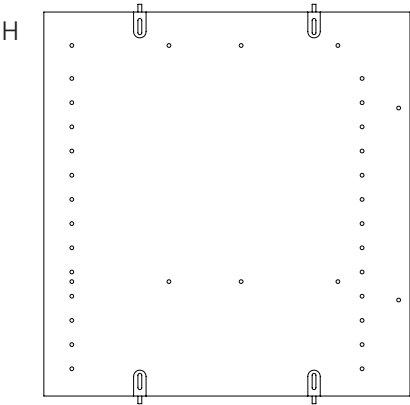

Step 1

- Place the top panel (G) on a flat, protected surface with the pilot holes facing up.
- Take the back panel (J) and align the cabineo connectors with the pre-drilled pilot holes on the top panel (G).
- Using the 4mm ball end screwdriver (C), screw the cabineo connectors to secure it to the top panel (G). See Figure A below to see how to use the 4mm ball end screwdriver (C).

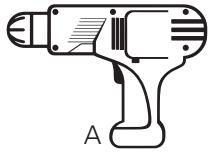

Cabineo Connector

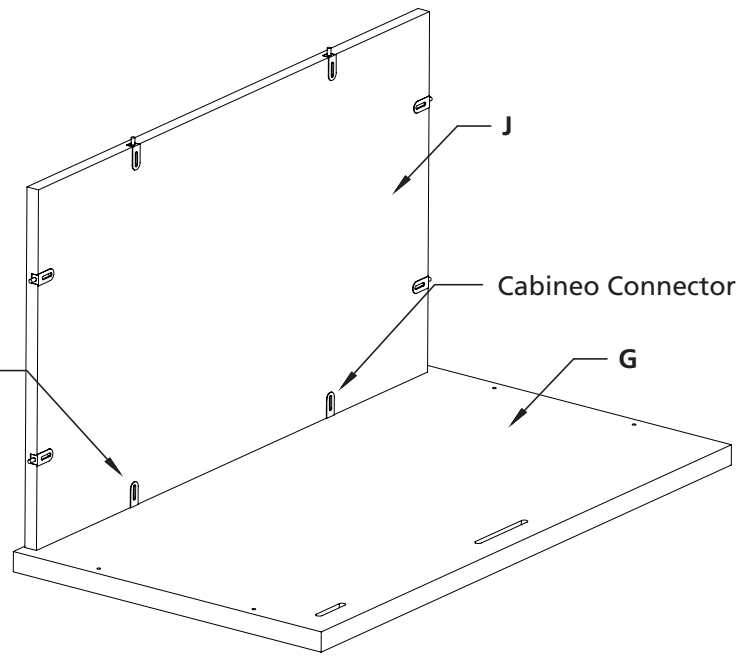
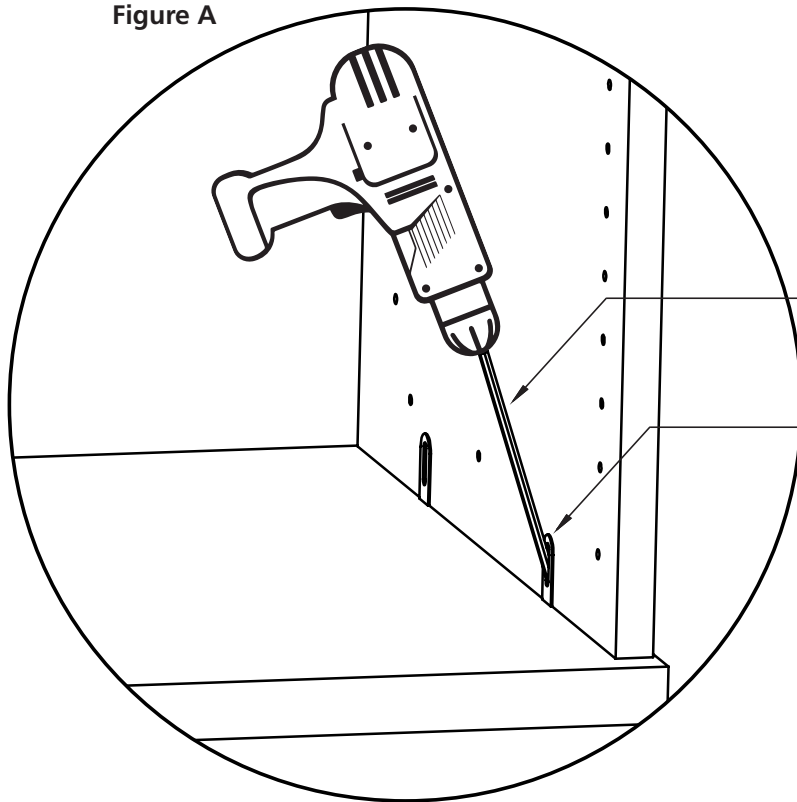

Figure A



4mm Ball End Screwdriver (C)

Cabineo Connector

Step 2

- Take the left panel (H) and align the cabineo connectors with the pre-drilled pilot holes on the top panel (G).
- Using the 4mm ball end screwdriver (C), screw the cabineo connectors on the left panel (H) to secure it to the top panel (G).
- Using the 4mm ball end screwdriver (D), screw the cabineo connectors on the back panel (J) to secure it to the left panel (H).

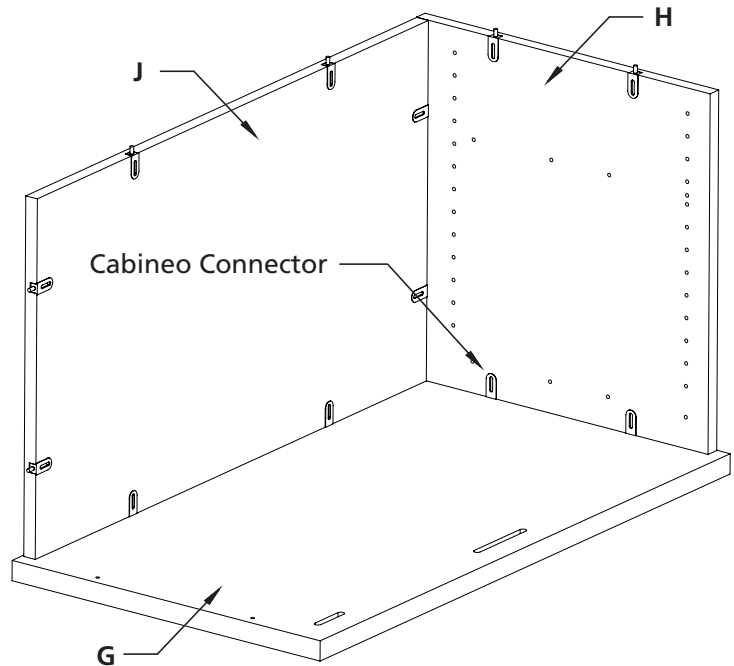
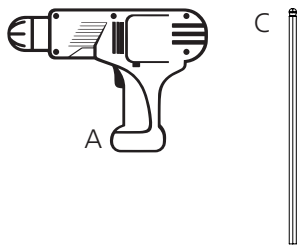

Step 3

- Take the right panel (I) and align the cabineo connectors with the pre-drilled pilot holes on the top panel (G).
- Using the 4mm ball end screwdriver (C), screw the cabineo connectors on the right panel (J) to secure it to the top panel (G).
- Using the 4mm ball end screwdriver (C), screw the cabineo connectors on the back panel (J) to secure it to the right panel (I).

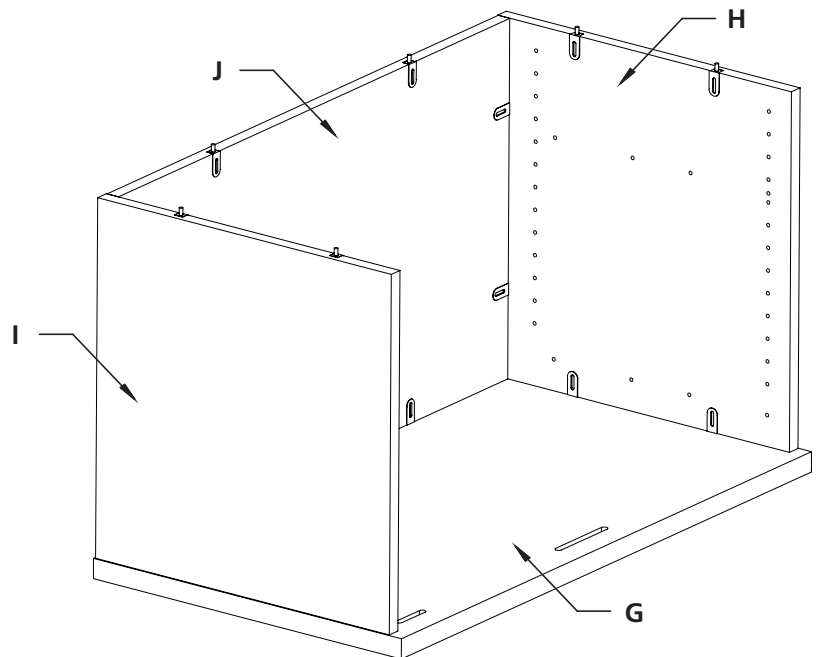
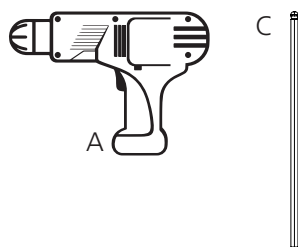

Step 4

- Place the bottom panel (F) onto the back and side panels as shown in the image. The side of the bottom panel (F) with more pilot holes should be facing upwards.
- Using the 4mm ball end screwdriver (C), screw the six (6) cabineo connectors on the back and side panels to secure them to the bottom panel (F).

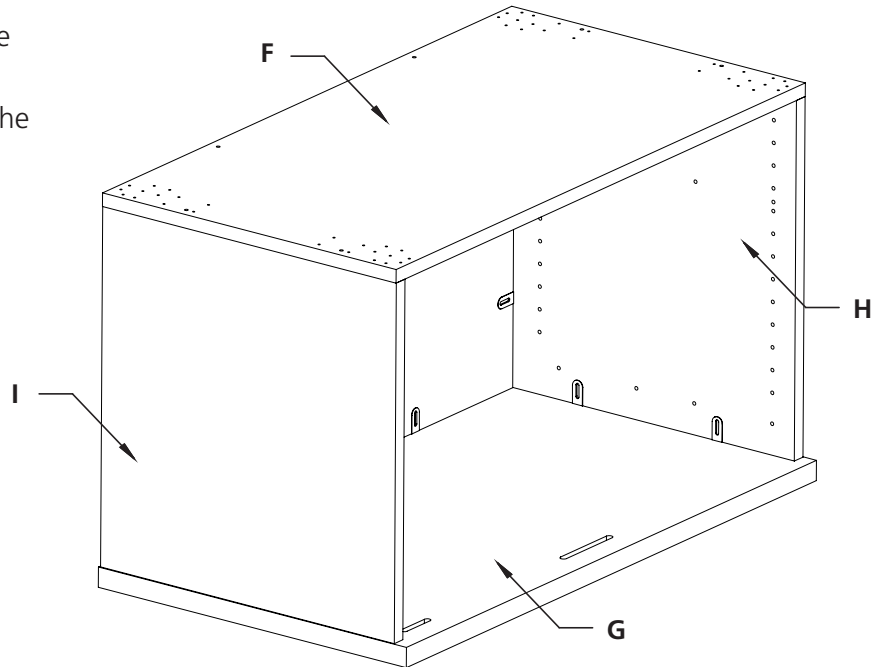
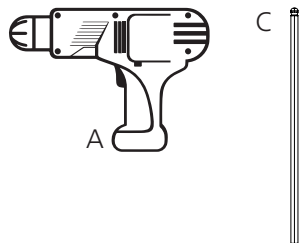

Step 5

- Align the feet (E) with the pre-drilled pilot holes on each of the corners of the bottom panel (F).
- Secure the feet to the bottom panel using four (4) washer head wood screws per foot.
- Flip the credenza right side up.

NOTE: Skip this step if adding the caster kit. Please refer to the instructions provided with the caster kit for install.

