

DIMENSIONS

- A AS CAST
- B AS CAST
- C 0.66
- D 0.72
- E 1.32 *
- F 1 1/4" NPT THREAD *

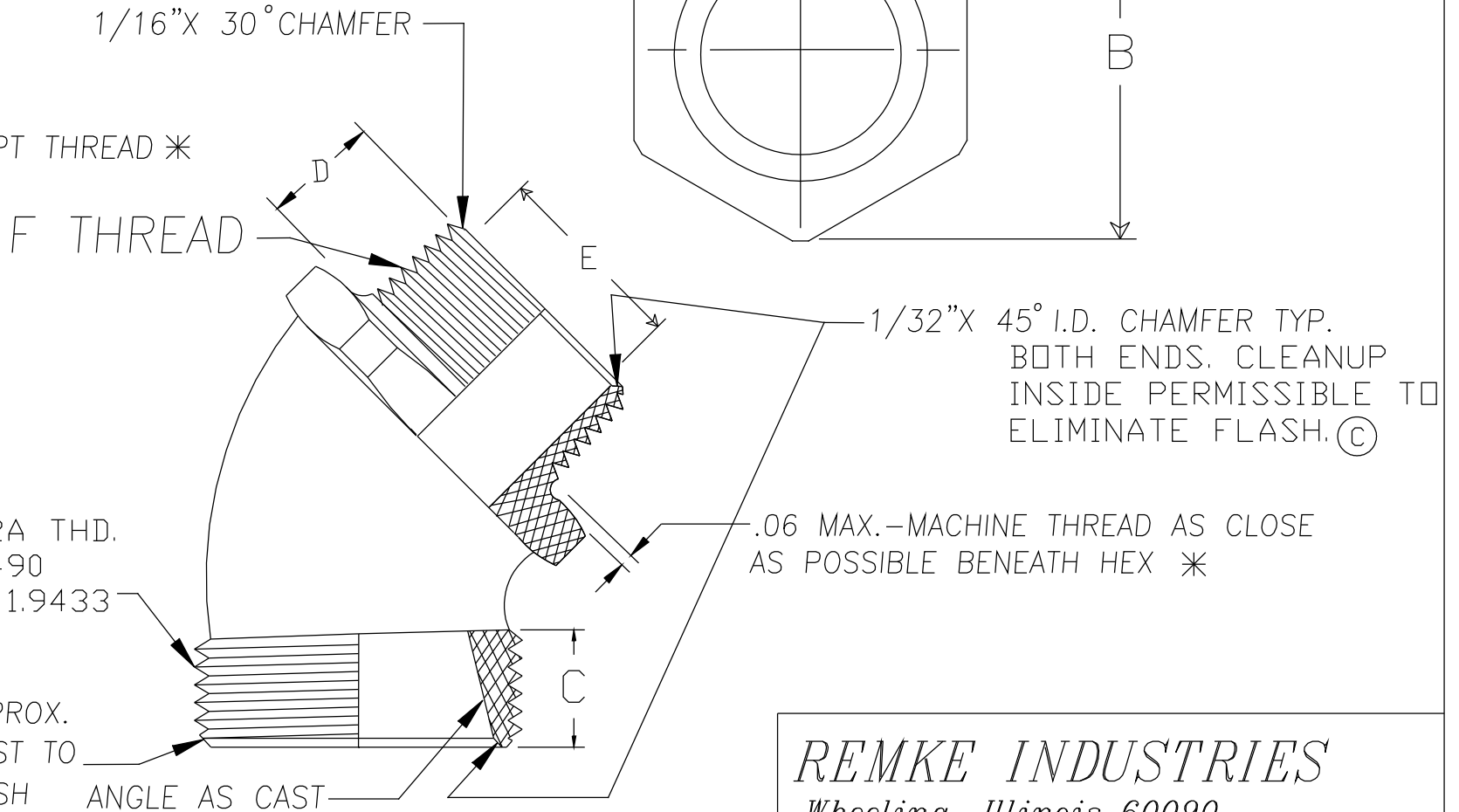
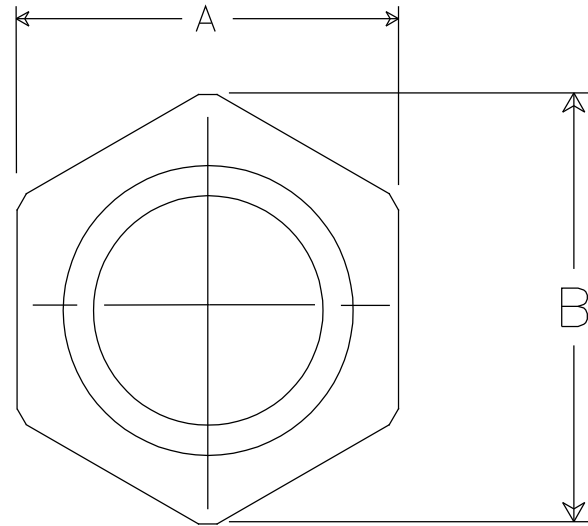

* 2-14 UNS-2A THD.
G.D. P.D. 1.9490
N.D. G.D. P.D. 1.9433

* .03 X 45° APPROX.
FACE OFF FIRST TO
ELIMINATE FLASH

ANGLE AS CAST

1/32" X 45° I.D. CHAMFER TYP.
BOTH ENDS. CLEANUP
INSIDE PERMISSIBLE TO
ELIMINATE FLASH. ©

.06 MAX.—MACHINE THREAD AS CLOSE
AS POSSIBLE BENEATH HEX *

REMKE INDUSTRIES
Wheeling, Illinois 60090

SCALE: APPROX FULL
MATERIAL: ALUM SAND CAST
FINISH: NATURAL
PART NAME: 45 DEGREE BODY
PART NUMBER: RSR-45400-B
DRAWING DATE: 920214

REV.	DATE	CHANGE	
A	7/2/99	REDRAWN USING CAD	UNLESS OTHERWISE SPECIFIED 3-PLC. DIM. +/- .005 2-PLC. DIM. +/- .010 1-PLC. DIM. +/- .015 FRACTIONAL +/- 1/64 ANGULAR +/- 1°
B	1/8/13	ADDED PITCH DIA. FOR 2'-14 THD.	
C	11/18/15	ADDED .031 X 45° CHAMFER TO BOTH ENDS; ADDED NOTES	