

Ø 1.25
NUT

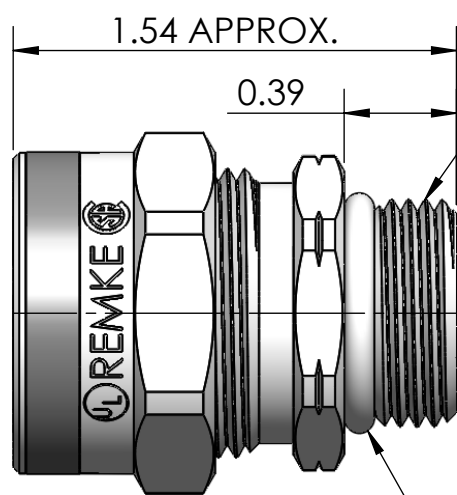

M 20

LOCK NUT
OPTIONAL
ADD: L

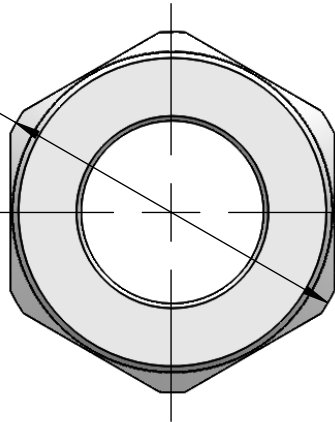
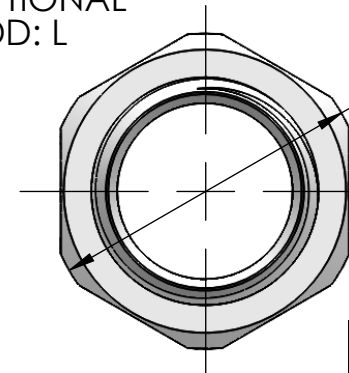

Ø 1.09
BODY

O-RING
OPTIONAL
ADD: R



ITEM NO.	PART NUMBER	DESCRIPTION	MATERIAL	QTY.
1	RSM-20100-B	BODY	ALUMINUM	1
2	SRB-103 - SRB-110	BUSHING	NEOPRENE	1
3	SW-100	WASHER	C.R.S. ZINC PLATED	1
4	RSR-100-N	NUT	ALUMINUM	1
5	SOR-38	O-RING	BUNA-N	1
6	RLM20-BR	LOCK NUT	BRASS, NICKLE PLATED	1

PART NUMBER	SEALING RANGE	BODY BORE
RSM-20103	.125 - .188	.610
RSM-20104	.188 - .250	.610
RSM-20105	.250 - .312	.610
RSM-20106	.312 - .375	.610
RSM-20107	.375 - .438	.610
RSM-20108	.438 - .500	.610
RSM-20109	.500 - .562	.610
RSM-20110	.562 - .625	.610

REV.	DATE	CHANGE	UNLESS OTHERWISE SPECIFIED:	NAME	DATE	REMKE REMKE INDUSTRIES 310 CHADDICK DR, WHEELING, IL. 60090	
A	6/14/13	DRAWING RELEASED	DIMENSIONS ARE IN INCHES TOLERANCES: FRACTIONAL ± 1/64 ANGULAR: MACH ± 1° BEND ± 1° ONE PLACE DECIMAL ± .015 TWO PLACE DECIMAL ± .010 THREE PLACE DECIMAL ± .005 INTERPRET GEOMETRIC TOLERANCING PER: MATERIAL ALUMINUM FINISH DO NOT SCALE DRAWING	DRAWN JCN CHECKED ENG APPR. MFG APPR. Q.A.	6/13	TITLE: RSM-20100 SERIES	
			PROPRIETARY AND CONFIDENTIAL THE INFORMATION CONTAINED IN THIS DRAWING IS THE SOLE PROPERTY OF REMKE INDUSTRIES. ANY REPRODUCTION IN PART OR AS A WHOLE WITHOUT THE WRITTEN PERMISSION OF REMKE INDUSTRIES IS PROHIBITED.			SIZE A	DWG. NO. RSM-20100 ASSEMBLY
			SCALE: 1.5:1			SHEET 1 OF 1	

5

4

3

2

1