

# Service Manual

Energy Recovery Ventilator

FV-11ES1

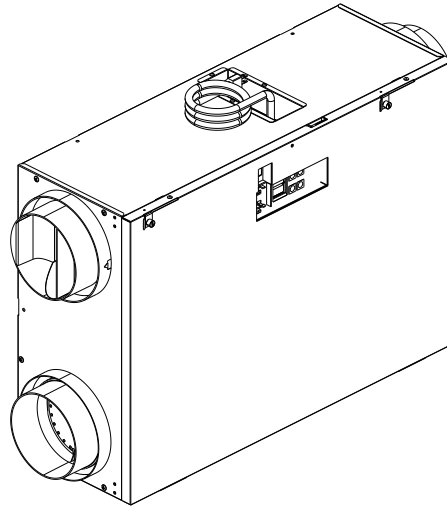

## ⚠ WARNING

This service information is designed for experienced repair technicians only and is not designed for use by the general public. It does not contain warnings or cautions to advise non-technical individuals of potential dangers in attempting to service a product. Products powered by electricity should be serviced or repaired only by experienced professional technicians. Any attempt to service or repair the product or products dealt with in this service information by anyone else could result in serious injury or death.

## IMPORTANT SAFETY NOTICE

There are special components used in this equipment which are important for safety. These parts are marked by ⚠ in the Schematic Diagrams, Exploded Views and Replacement Parts List. It is essential that these critical parts should be replaced with manufacturer's specified parts to prevent shock, fire or other hazards. Do not modify the original design without permission of manufacture.

We suggest to handle such parts after the static electricity prevention.

It is forbidden to touch the PCB parts by bare hands during the repairing process.

CONTENTS	PAGE
1.Specifications -----	1
2.Parts Identification-----	2~5
3.Wiring Diagram -----	6
4.Maintenance-----	7~8
5. Troubleshooting-----	9~10
6.Parts List-----	11~12

# 1. Specifications

## <Ventilation Performance>

Model No.	Voltage (V)	Frequency (Hz)	Duct	Static pressure	Net air flow (CFM)		Power consumption (W)	Weight lb.(kg)
					Exhaust	Supply	Fan unit	
FV-11ES1	120	60	6"	0.2"WG	110	110	62	51 (23)
				0.4"WG	110	110	78	

## <Energy Performance>

Model No.	Mode	Supply temperature		Net air flow		Power consumption (W)	Sensible recovery efficiency	Adjusted sensible recovery efficiency	Net moisture transfer
		°F	°C	L/s	CFM				
FV-11ES1	Heating	32	0	17	36	21	88	92	0.87
		32	0	30	64	33	83	86	0.78
		32	0	52	110	62	75	79	0.71
	Cooling	Total recovery efficiency							
		95	35	17	36	22	82		
		95	35	30	64	34	76		
95	35	52	110	64	64				

The testing of the ventilation performance and the energy performance is in accordance with CSA-C439-18 standard.

# 2. Parts Identification

FV-11ES1

## Main Body Section

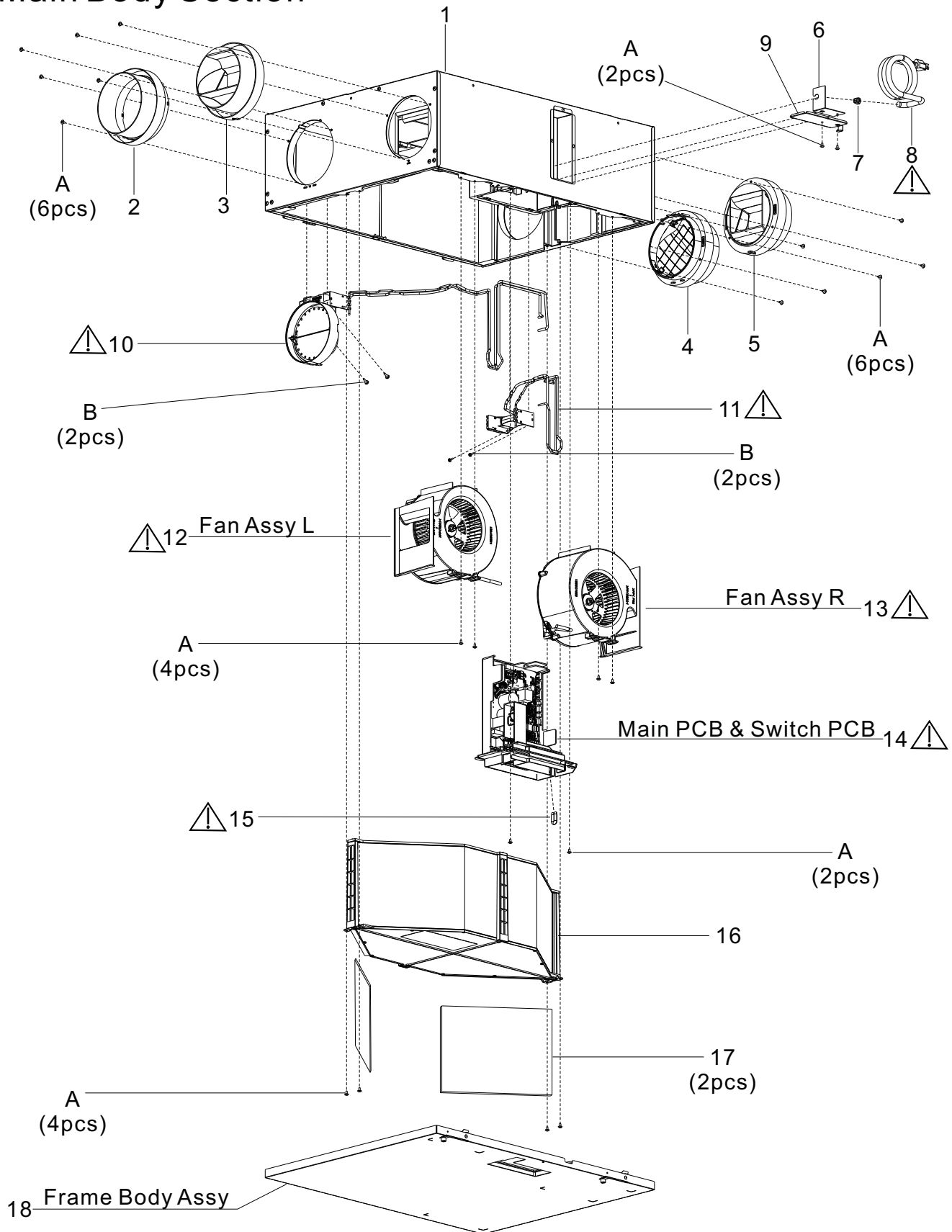



# 2. Parts Identification

FV-11ES1

## Frame Cover Assy

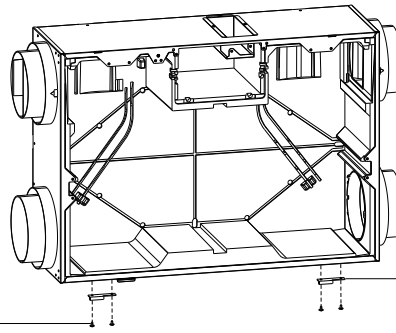

A  
(2pcs)

33  
(2pcs)

## Main Labels

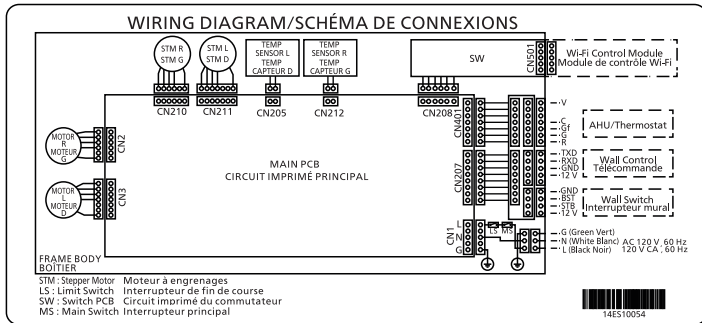

**WARNING**  
ELECTRICAL CORDS CAN BE HAZARDOUS

- Misuse Can Result in Fire or Death;
- Cord Shall be Secured Out of the Way;
- Avoid Overheating, Uncoil Cord and Do Not Cover It With Any Material;
- Do not Walk on Cord;

**AVERTISSEMENT**  
LES CORDONS ELECTRIQUES PEUVENT ETRE DANGEREUX

- Une mauvaise utilisation peut causer un incendie ou la mort ;
- Le cordon doit être bien fixé à l'abri du passage ;
- Évitez le surchauffe, Déroulez le cordon et ne le couvrez pas avec d'autres matériaux ;
- Ne marchez pas sur le cordon ;

35

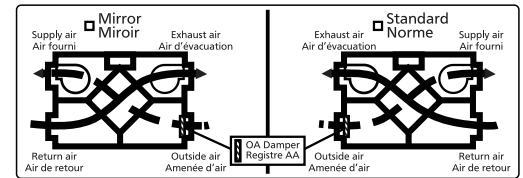

36

**CAUTION**

- Electric shock may result. Disconnect power by switching off main switch first, then unplug before working on unit when it is in default mode. (Fig.1)
- Electric shock may result. Disconnect power by switching off wall switch first, then main switch and unplug before working on unit when replacing the jumper cable with wall switch.
- Routine maintenance must be performed every 2 or 3 months. Clogged filters may cause condensation on the unit due to air flow reduction.
- Please wear gloves to avoid pinching fingers during maintenance.
- Please pay attention to dust, condensation water or parts that may drop down when the covers are opened.

**ATTENTION**

- Risque de choc électrique. Coupez l'alimentation avec l'Interrupteur principal d'abord, puis débranchez avant de travailler sur l'appareil lorsqu'il est en mode par défaut. (Fig.1)
- Risque de choc électrique. Coupez l'alimentation avec l'Interrupteur mural d'abord, puis l'Interrupteur principal et débranchez avant de travailler sur l'appareil pour remplacer la connexion temporaire par un interrupteur mural.
- Une maintenance périodique doit être réalisée tous les 2 à 3 mois, car des filtres obstrués peuvent entraîner de la condensation dans l'unité à cause de la réduction du flux d'air.
- Vous devez porter des gants pour éviter de vous pincer les doigts pendant la maintenance.
- Vous devez faire attention à la poussière, à la condensation ou aux pièces qui pourraient tomber lorsque vous ouvrez la couverture.

**MAINTENANCE PROCEDURE**

- Open the door by unlatching the levers.
- If not convenient for maintenance you can also unlock the lock plate and remove the frame cover. (Fig.2)
- Remove filters to clean with vacuum cleaner. (Fig.3)
- Reinstall the filters. Make sure the direction of the arrow on the filters are correct. (Fig.4)
- Reinstall and close door by locking the lock plate and levers. (Fig.5)
- Connect power, press filter reset button with sound of "beep" then filter indicator and buzzer sound will be off. (Fig.6)

**PROCÉDURE DE MAINTENANCE**

- Ouvrez la porte en déverrouillant les leviers. Si cela n'est pas pratique pour la maintenance, vous pouvez également déverrouiller la plaque de verrouillage et retirer le couvercle. (Fig.2)
- Enlevez les filtres pour les nettoyer avec un aspirateur. (Fig.3)
- Reinstallez les filtres. Assurez-vous que le sens de la flèche sur les filtres est correcte. (Fig.4)
- Reinstallez la porte puis verrouillez la plaque de verrouillage et les leviers et fermez. (Fig.5)
- Branchez l'appareil, appuyez sur le bouton de réinitialisation, un bip "beep" de fin d'entente, le voyant du filtre et le sont désactivés. (Fig.6)

34

37

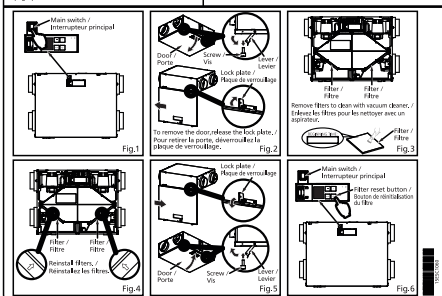

38

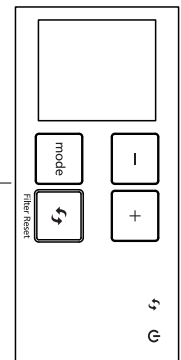

# 2. Parts Identification

FV-11ES1

## Packing Case Assy

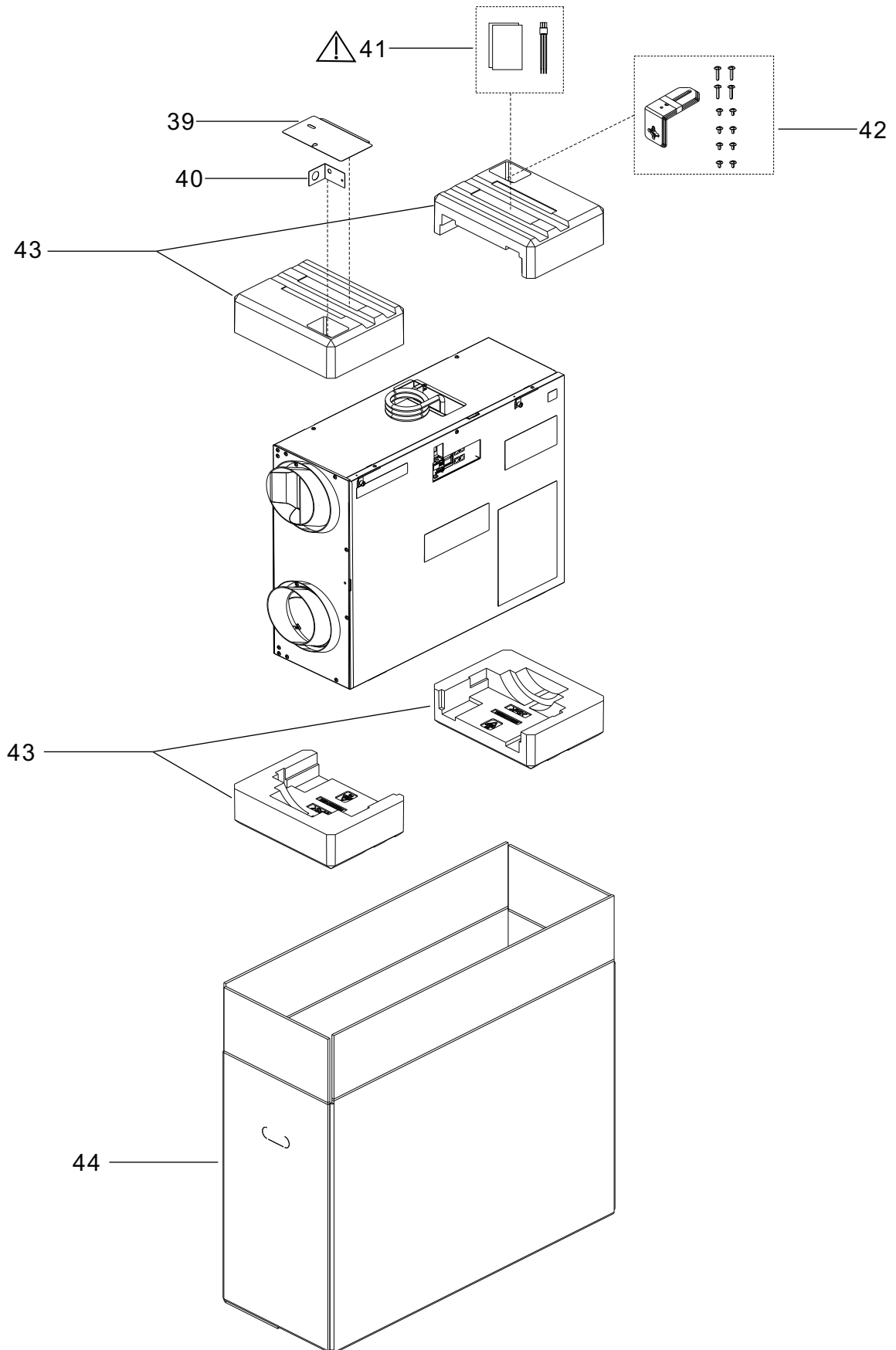

# 3. Wiring diagram



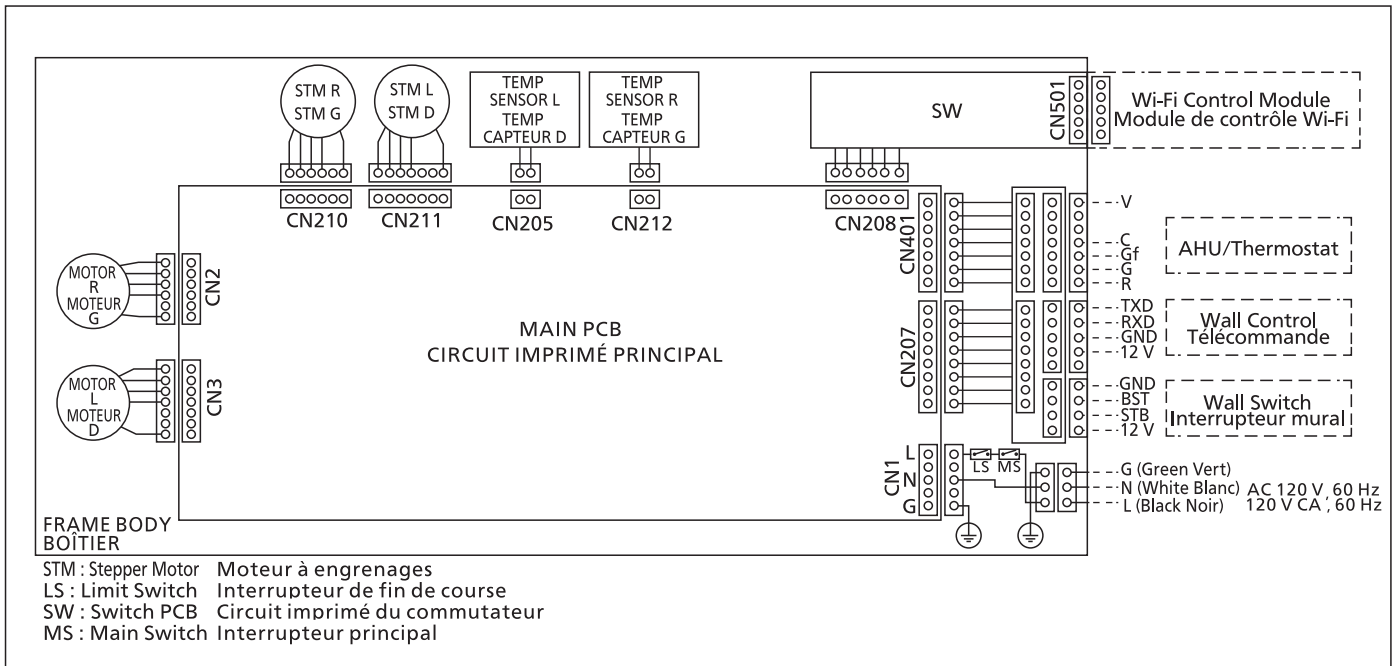



FV-11ES1



## 4.Maintenance

FV-11ES1

### CAUTION

-  Electric shock may result. Disconnect power by switching off main switch, then unplug before working on the unit. If a standby switch is connected, it is recommended to switch it off first.
-  Routine maintenance must be performed every 2 or 3 months. Clogged filters may cause condensation on the unit due to air flow reduction.
-  Wear gloves to avoid pinching fingers during maintenance.
-  Pay attention to dust, condensation water, or parts that may drop down when the door is opened.
-  Never use gasoline, benzene, thinner or any other such chemicals to clean the ERV.
-  Do not allow water to enter ERV.
-  Do not immerse resin parts in water over 60 °C.

- 1** Open the door by releasing the levers.

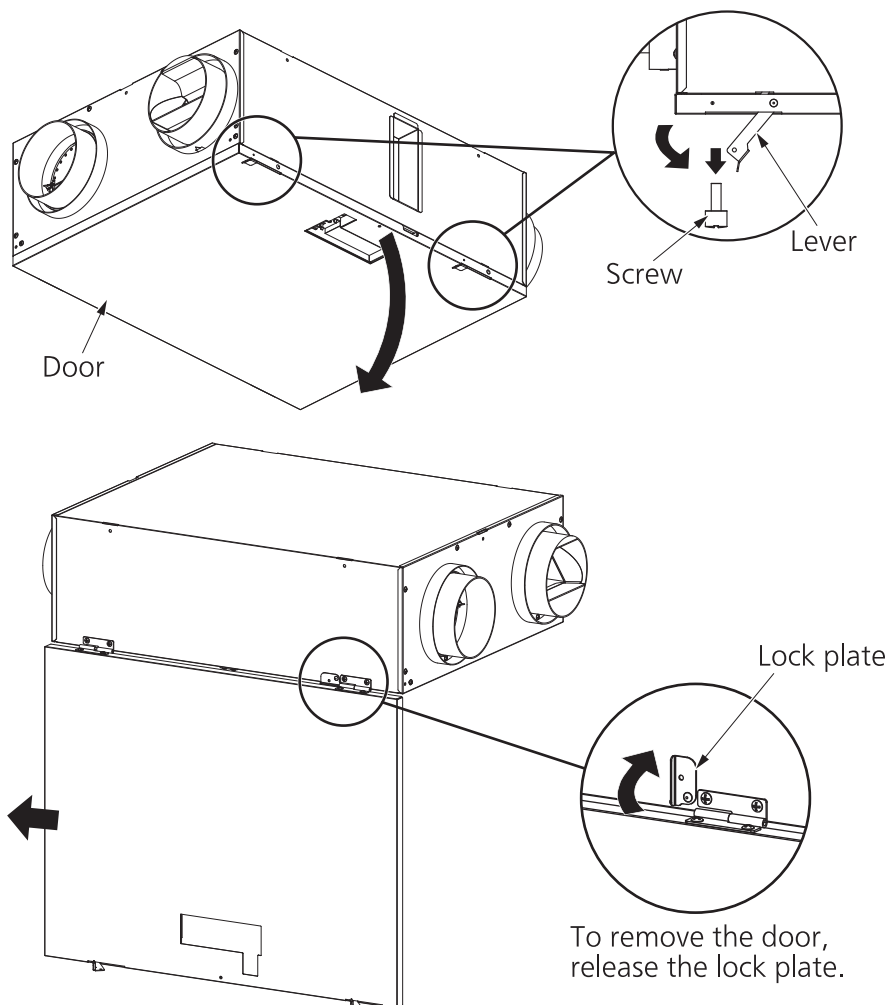

# 4. Maintenance

FV-11ES1

2 Clean the filters.

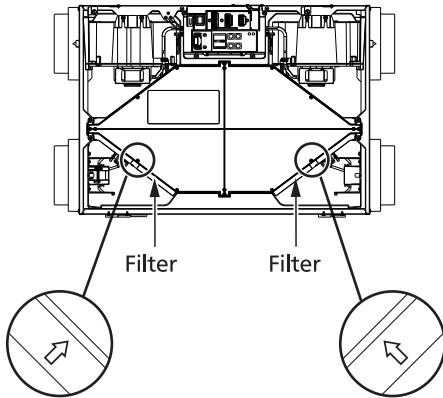

It is suggested to replace the filters every 6 months. Please fill in beginning time on new filters before replacing.

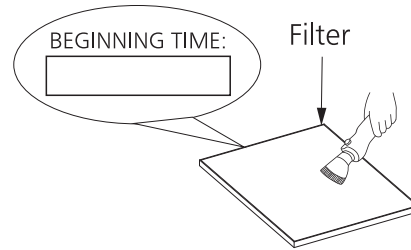

3 Reinstall the filters.

4 Reinstall and close door by putting back the levers.

5 Connect power and press filter reset button. When the unit beeps, the filter reset timer will be reset.

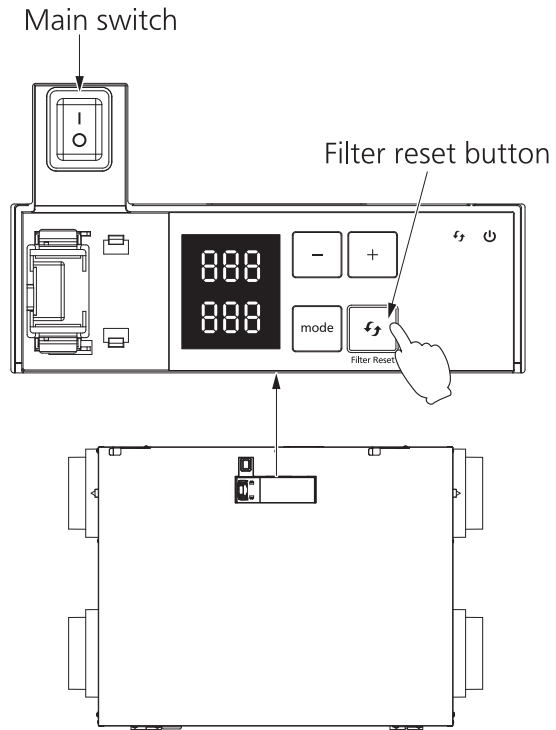
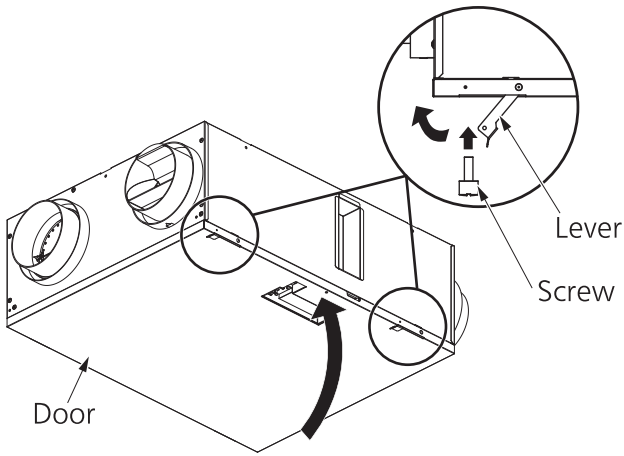

# 5. Troubleshooting

FV-11ES1

If a problem is encountered, please investigate it by going through the following items.  
If the problem still persists, please disconnect the power and contact the dealer for repair.

Problem	Display	Running indicator (Green)	Filter indicator (Orange)	Action
1.The ERV doesn't work.	-	Off	Off	<ul style="list-style-type: none"> <li>■ Check the power is connected.</li> <li>■ Check the door is closed.</li> <li>■ Check that the main switch on the product is on.</li> <li>■ Check if the spring on the inside of the door is damaged or deformed.</li> </ul>
		On	Off	<ul style="list-style-type: none"> <li>■ ERV running interval according to the ASHRAE time setting.</li> <li>■ When outdoor temperature is very low ERV stops operating automatically.(see P.4)</li> </ul>
2.The HVAC/AHU doesn't work when ERV works.	-	On	Off	<ul style="list-style-type: none"> <li>■ Check the wiring connection. (P.6-7)</li> </ul>
3.Alarm sounds (10 sec every hour) and ERV works.	-	On	On	<ul style="list-style-type: none"> <li>■ The filters need to be maintained. If you do not want the buzzer notification, see configuration setting (p.20-21).</li> </ul>
4.Alarm sounds (30 sec every hour) and ERV doesn't work.	F03	Blink	Off	<ul style="list-style-type: none"> <li>■ PCB error, please disconnect the power and contact the dealer for repair.</li> </ul>
	F10	Blink	Off	<ul style="list-style-type: none"> <li>■ OA temperature sensor error, please disconnect the power and contact the dealer for repair.</li> </ul>
	F20	Blink	Off	<ul style="list-style-type: none"> <li>■ SA motor error, please disconnect the power and contact the dealer for repair.</li> </ul>
	F21	Blink	Off	<ul style="list-style-type: none"> <li>■ EA motor error, please disconnect the power and contact the dealer for repair.</li> </ul>
	H31	Blink	Off	<ul style="list-style-type: none"> <li>■ OA damper connection failure. Check the damper connection. (P.12-13)</li> </ul>
	H32	Blink	Off	
	H33	Blink	Off	
	F60	Blink	Off	<ul style="list-style-type: none"> <li>■ Supply air flow is significantly decreasing. Check the ducting and the filter.</li> </ul>
	F61	Blink	Off	<ul style="list-style-type: none"> <li>■ Exhaust air flow is significantly decreasing. Check the ducting and the filter.</li> </ul>
5.Alarm sounds (30 sec every hour) and ERV works.	F01	Blink	Off	<ul style="list-style-type: none"> <li>■ Wall control communication error. Check the wall control wiring.(P.6-7)</li> </ul>
	F04	Blink	Off	<ul style="list-style-type: none"> <li>■ PCB communication error. Contact the dealer for repair. *</li> </ul>
	F11	Blink	Off	<ul style="list-style-type: none"> <li>■ OA humidity sensor error. Contact the dealer for repair. *</li> </ul>
	F12	Blink	Off	<ul style="list-style-type: none"> <li>■ RA temperature sensor error. Contact the dealer for repair. *</li> </ul>
	F13	Blink	Off	<ul style="list-style-type: none"> <li>■ RA humidity sensor error. Contact the dealer for repair. *</li> </ul>

\*Some functions will be limited when this error is encountered.

## 5. Troubleshooting







FV-11ES1

Problem	Display	Running indicator (Green)	Filter indicator (Orange)	Action
5. Alarm sounds (30 sec every hour) and ERV works.	F30	Blink	Off	■ Damper error, please disconnect the power and contact the dealer for repair.
	H60	Blink	Off	■ Supply air flow is decreasing. Check the ducting and the filter.
	H61	Blink	Off	■ Exhaust air flow is decreasing. Check the ducting and the filter.
6. ERV behaves differently from the selected air flow settings.	-	On	Off	<ul style="list-style-type: none"> <li>■ When product runs in recirculation mode for frost prevention, the air volume will be more than setting and sound will be slightly louder than normal operation.</li> <li>■ When outdoor temperature is less than 23 °F (-5 °C), the product will restrict air volume automatically to protect energy recovery core.</li> </ul>

## 6. Parts List

FV-11ES1

### Main Body Section

No.	Part No.	Part Name	Q'ty	Remark
1	FFV14ES10931	Main Frame Assy	1	
2	FFV15ESC1917	RA OA Adapter L	1	
3	FFV15ESC1915	Adaper L	1	
4	FFV15ESC1918	RA OA Adapter R	1	
5	FFV15ESC1916	Adapter R	1	
6	FFV15ESC1951	Wiring Cover P	1	
7	FV0720012S	Corde Bushing	1	
8	FFV16VC1T204A	Power Cord	1	
9	FFV15ESC1955	Junction Cover	1	
10	FFV15ESC1520	Damper Assy L	1	
11	FFV15ESC1521	Damper Assy R	1	
12	FFV15ESC1M1L	Fan Assy L	1	
13	FFV15ESC1M1R	Fan Assy R	1	
14	FFV11ES1MS	Main PCB and Switch PCB	1	
15	FFV2800028S	Jumper Cable	1	
16	FFV15ESC1990	Element Comp Unit	1	
17	FFV15ESC1801	OA Filter M13	1	
18	FFV14ES10932	Frame Cover Assy	1	
A	FFVXTT4-8FFJ	Screw (ST4-8)	24	
B	FFVXTN3-8GFJ	SCREW (M3-8)	6	

### Frame Body Assy

No.	Part No.	Part Name	Q'ty	Remark
19	FFV2220076S	Hinge A	2	
20	FFV00TMM0501E	Tsumami	2	
A	FFVXTT4-8FFJ	Screw (ST4-8)	4	

## 6. Parts List

FV-11ES1

### L Fan Assy/R Fan Assy

No.	Part No.	Part Name	Q'ty	Remark
21	FFV15ESC1925	Motor Base A	2	
22	FFV15ESC1M21C	Motor L Set	1	⚠
23	FFV15ESC1M23C	Motor R Set	1	⚠
24	FFV15ESC1926	Motor Base B	2	
25	FFV15ESC1923	Motor Base L	1	
26	FFV15ESC1924	Motor Base R	1	
27	FFV7010055S	Washer	2	
28	FFV10VC2948	Blade	2	
29	FFV10VC2R9	Fix Plate	2	
30	FFV10VC2M920	Flange Nut	2	
31	FFV15ESC1921	Casing L	1	
32	FFV15ESC1922	Casing R	1	
A	FFVXTT4-8FFJ	Screw (ST4-8)	4	
C	FFVXTT4-12GFJ	Screw (ST4-12)	8	

### Frame Cover Assy

No.	Part No.	Part Name	Q'ty	Remark
33	FFV2220075M	Hinge B	2	
A	FFVXTT4-8FFJ	Screw (ST4-8)	4	

### Main Labels

No.	Part No.	Part Name	Q'ty	Remark
34	FFV14ES10054	Wiring Label	1	
35	FFV4690029M	Power Cord Label	1	
36	FFV15ESC1062	Mirror Inst Label	1	
37	FFV15ESC1060	Maintenance Label	1	
38	FFV15ESC1053	Switch label	1	

### Packing Case Assy

No.	Part No.	Part Name	Q'ty	Remark
39	FFV15ESC1206	Interface Cover	1	
40	FFV15ESC1952	Wiring Cover H	1	
41	FFV15ESC1460	Accessory Set	1	⚠
42	FFV15ESC1461	Accessory For Screws	1	
43	FFV15ESC1401	Packing Pad A	4	
44	FFV11ES10420	Packing Case Assy	1	