

DETAIL B
SCALE 4 : 1

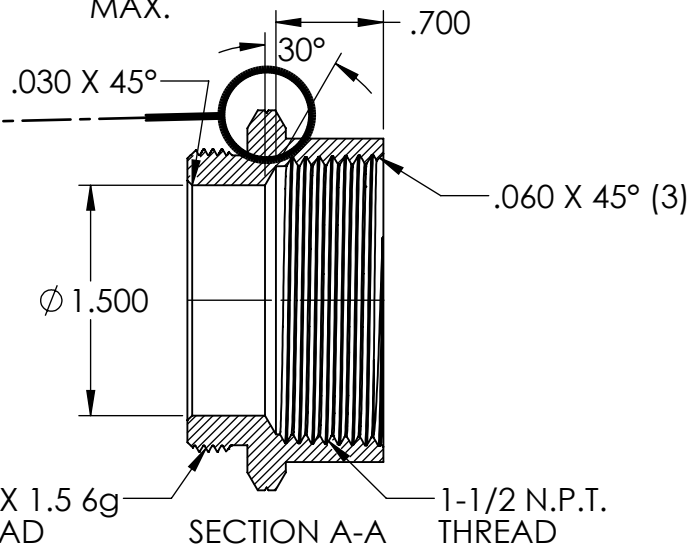
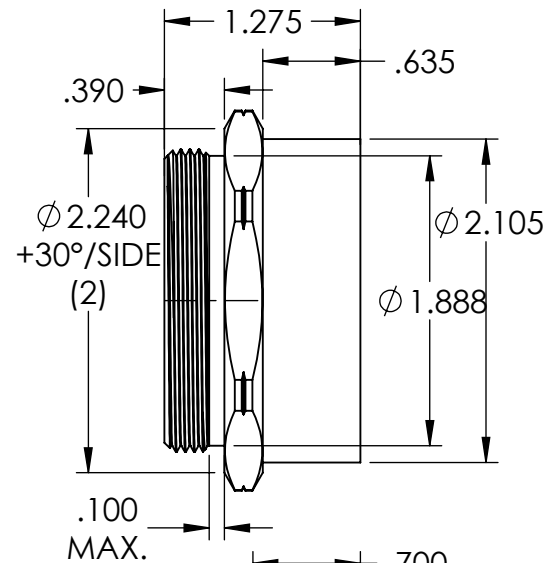

NOTES:

- 1.) PART A IS PLATED ELECTROLESS NICKEL .0001 MIN-.0003 MAX.
- 2.) PART UP IS UNPLATED
- 3.) BREAK ALL SHARP CORNERS
- 4.) REF. BAR-37 (2"-1/4 HEX x 1.290 I.D.)

REV.	DATE	CHANGE	UNLESS OTHERWISE SPECIFIED:	NAME	DATE	REMKE REMKE INDUSTRIES 310 CHADDICK DR, WHEELING, IL. 60090		
A	2/27/02	DRAWING RELEASED C.V.	DIMENSIONS ARE IN INCHES	DRAWN	JCN	7/15	TITLE: <h1 style="text-align: center;">ADAPTER</h1>	
B	4/16/02	FRONT END REDRAWN ROUND WAS HEX	TOLERANCES:	CHECKED				
C	2/11/03	"H" DIA. 1.892 WAS 1.900 & "L" DIA 2.105 WAS 2.190	FRACTIONAL ± 1/64	ENG APPR.				
D	8/27/14	REDRAWN	ANGULAR: MACH ± 1° BEND ± 1°	MFG APPR.				
F	7/22/15	REDRAWN	ONE PLACE DECIMAL ± .015	Q.A.				
			TWO PLACE DECIMAL ± .010	PROPRIETARY AND CONFIDENTIAL THE INFORMATION CONTAINED IN THIS DRAWING IS THE SOLE PROPERTY OF REMKE INDUSTRIES. ANY REPRODUCTION IN PART OR AS A WHOLE WITHOUT THE WRITTEN PERMISSION OF REMKE INDUSTRIES IS PROHIBITED.			SIZE	DWG. NO.
			THREE PLACE DECIMAL ± .005				A	RAM-50M150F-A
			INTERPRET GEOMETRIC TOLERANCING PER:	SCALE: 0.8:1			SHEET 1 OF 1	
			MATERIAL					
			ALUMINUM					
			FINISH					
			NICKEL PLATED					
			DO NOT SCALE DRAWING					

5

4

3

2

1