

LOCK NUT
OPTIONAL

O-RING

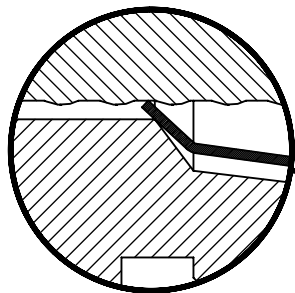

DETAIL B
SCALE 1.5 : 1

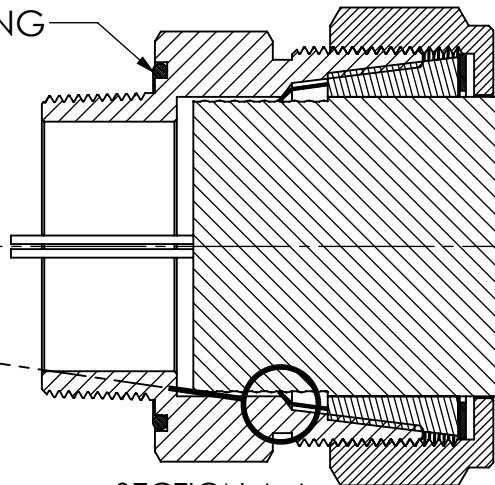

SECTION A-A

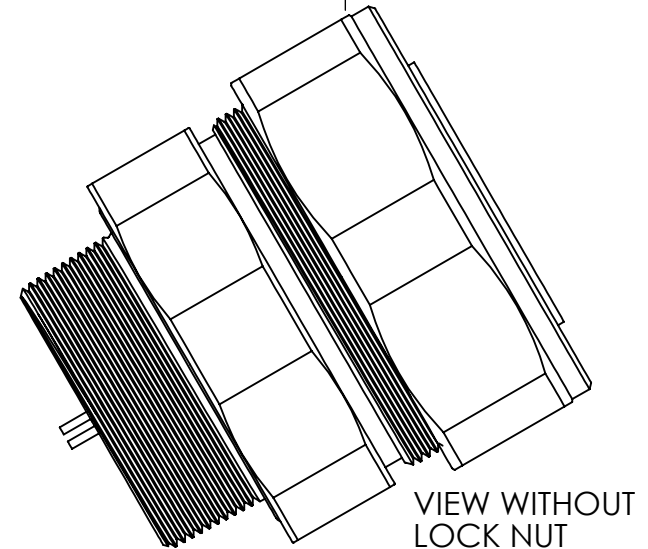

REV.	DATE	CHANGE	UNLESS OTHERWISE SPECIFIED:	NAME	DATE	REMKE REMKE INDUSTRIES 310 CHADDICK DR, WHEELING, IL. 60090	
A	12/3/13	RELEASED DRAWING	DIMENSIONS ARE IN INCHES TOLERANCES: FRACTIONAL $\pm 1/64$ ANGULAR: MACH $\pm 1^\circ$ BEND $\pm 1^\circ$ ONE PLACE DECIMAL $\pm .015$ TWO PLACE DECIMAL $\pm .010$ THREE PLACE DECIMAL $\pm .005$	DRAWN JCN	12/13	TITLE:	
			INTERPRET GEOMETRIC TOLERANCING PER:	CHECKED		SIZE DWG. NO.	
			MATERIAL STAINLESS	ENG APPR.		A RTKSS-350-26	
			FINISH	MFG APPR.		SCALE: 1:2.5	
			DO NOT SCALE DRAWING	Q.A.		SHEET 1 OF 1	
				PROPRIETARY AND CONFIDENTIAL THE INFORMATION CONTAINED IN THIS DRAWING IS THE SOLE PROPERTY OF REMKE INDUSTRIES. ANY REPRODUCTION IN PART OR AS A WHOLE WITHOUT THE WRITTEN PERMISSION OF REMKE INDUSTRIES IS PROHIBITED.			