

Pin assignment

X1	X2	Remark
X1.12	X2.19	Pair
X1.13	X2.18	
X1.14	X2.20	Drain wire
X1.18	X2.13	Pair
X1.19	X2.12	
X1.20	X2.14	Drain wire

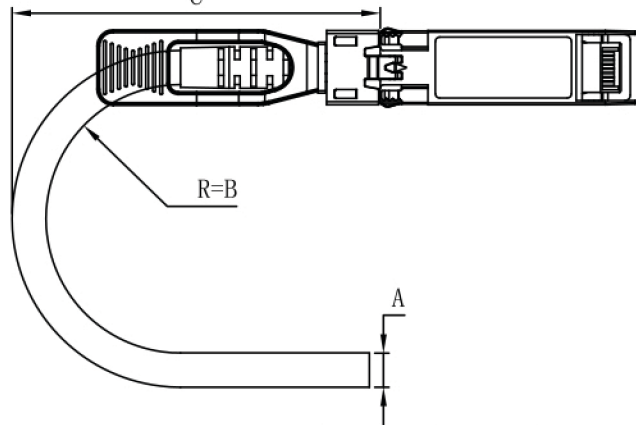

Cable gauge	30AWG	28AWG	24AWG
A(Cable Diameter)	4.2mm	4.7mm	6.0mm
B(Mini Outer Radius)	22.5mm	23.5mm	30mm
C(Faceplate to Outer Radius)	30.5mm	31.5mm	38mm
L(Length)	1~3m	3.5~4m	4.5~10m

NO.	PART NAME	DESCRIPTION	REMARK
9	Sleeve	PVC, BLUE	
8	SFP+ raw Cable	10G High Speed Cables 100Ω 2Pairs	
7	Boot	LSZH, Black	
6	Main Label	/	
5	PCBA	Material:FR4, 20PIN	
4	Latch	Nylon, Black	
3	Screw	304# Stainless steel	
2	Shield	304# Stainless steel	
1	Shell	Zinc Diecast, nickel Plated	

UNLESS OTHERWISE SPECIFIED DIMENSIONS ARE IN METRIC TOLERANCE ARE:	CAD GENERATED DRAWING. DO NOT MANUALLY UPDATE
DECIMALS	THE FIRST VIEW
ANGLES	APPROVALS / DATE
X. ±0.20	
.XX ±0.15	
.XXX ±0.10	
±1/2	
±0.05	



TITLE: SFP+ PASSIVE CABLE

SIZE A4 PART NO: SFP-10G-SFP-xxM REV. A0

SCALE: CAD FILE: SHEET: 1 OF 1

DATE	REVISION	ISSUE
	NEW REVISION	A2
		A1
		A0

MATERIAL:	DESIGNED
SURFACE AND COLOR:	CHECKED
CUSTOMER:	APPROVED